



# Moulding Supplies

Edition 9





NEW IN 2018

# NEW ENTRIES

2018

**MOULD SUPER FINISHING STONES**

Wide range of ceramic stones for polishing. Available in 8 grit sizes for all surfaces.

**NEW**

**193**

**HEAT SAFETY SLEEVE**

Now available in pure Red and Blue for easy identification of hoses and cables.

**NEW**

**50**

**END OF ARM TOOLING**

Extended range of End of Arm Tooling. New grippers, clamps, vacuum cups, quick changers and many more.

**NEW**

**163**

**CAMLOCK COUPLINGS**

In premium quality made of aluminum. Available in sizes from 3/4" to 3".

**NEW**

**128**

**COOLING CONNECTORS**

Rotatable connectors, NPT converters, flat face hose connectors etc.

**NEW**

**83**

**FITTINGS AND HOSES**

Pneumatic Push-In fittings and hoses.

**NEW**

**171**

**MAINTENANCE SPRAYS**

New Large Can size aerosols and new maintenance sprays.



**NEW**

**97**

**PTFE HOSES**

With Silicone Jackets to ensure safe and easy identification of cooling circuits.



**NEW**

**48**

**FLOW MONITOR**

FloSense Multi Sensor Monitor Delta T and Delta P Monitoring.



**NEW**

**81**

**BALL VALVES**

3 Way Ball Valves Premium quality.



**NEW**

**72**

**HOPPER MAGNETS**

Extra high strength hopper magnets with Neodymium core.



**NEW**

**135**

**TEMPERATURE CONTROLS**

Expanded range of Water and Oil units.



**NEW**

**90**

# CONTENTS

## MOULDING SUPPLIES EDITION 9



7

01 MOULD COOLING



80

02 FLOW MEASUREMENT AND CONTROL



96

03 CONSUMABLES

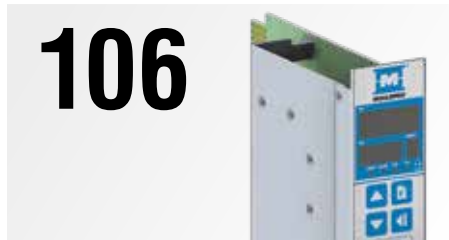

106

04 TEMPERATURE CONTROL



124

05 MATERIAL HANDLING



138

06 END OF ARM TOOLING (EOAT)



172

07 END OF BARREL



178

08 TOOLS & ACCESSORIES



202

09 MACHINE ACCESSORIES



212

10 MOULD CLAMPING



218

11 LIFTING



224

12 MOULD COMPONENTS

# 01.

## MOULD COOLING

**8**

01.1 COUPLERS



**43**

01.2 HOSES



**50**

01.4 HOSE PROTECTION



**52**

01.3 HOSE CLAMPING



**55**

01.5 FITTINGS



**68**

01.6 VALVES



**73**

01.7 PUSH IN FITTINGS



**75**

01.8 MANIFOLDS



**78**

01.9 SEALANT & TAPE



# 01.1

## COUPLERS

### 10

01.1.1 INTERNATIONAL SERIES 20 / 30 / 50

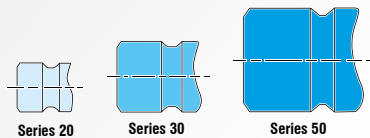

### 18

01.1.2 EUROPEAN SERIES 09 / 13 / 19

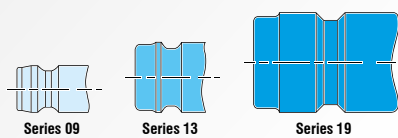

### 30

01.1.3 FRENCH SERIES 08 / 12

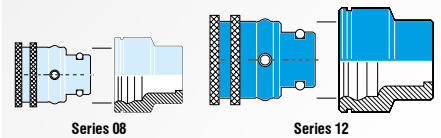

### 36

01.1.4 FRENCH MATIC SERIES 6 / 9 / 12 / 16 / 25



### 41

01.1.5 MULTI COUPLINGS SERIES



## EXPLANATION OF SYMBOLS



Water



Oil



Temperature max.



High Temperatures up to 180°C



Only in combination with Push-Lock hose and Push-Lock hosedetail



Safelock



Optional colour clips see page 24





## SAFE-LOCK™

The products marked with this system are fitted with the SAFE-LOCK™ technology developed by our designers.



Using a special mechanism, the SAFELOCK™ technology reliably prevents accidental uncoupling of the systems under pressure. As the normally contiguous temperatures of the media used are between 90°C and 170°C, accidents of this nature can result in serious burns. The only alternatives to the SAFE-LOCK™ systems are double shut-off couplings, with which, however, the complex valve technology has a strong negative impact on the flow values.

### SAFE-LOCK™ Coupling Systems

- Reliably eliminate the risk of serious burns
- Cannot be disconnected under pressure
- Are available both for our European and International ranges
- Are 100 % compatible with our standard systems and are therefore also easy to retrofit at a later date
- Are resistant to oil and water up to 140°C (Peak 160°C) HT-Series up to 180°C
- Are compliant with EU safety directive 97/23/EF

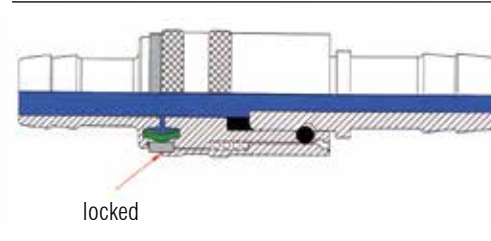
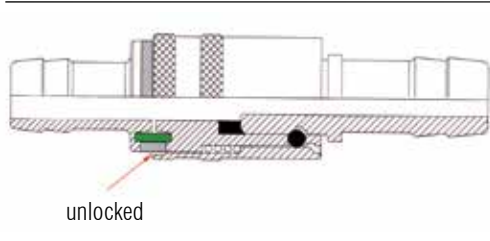

### Instructions for non-pressurized cooling systems:

Safe-lock is activated by pressure of min. 0,8bar - therefore you must ensure that your cooling circuit is pressurized at all time.

Low temperature (0-90°C) temperature controls typically operates with open tank (no pressure) and the pump cannot ensure pressure throughout the entire system.

To pressurize these systems, it's required to install a safety valve on the return inlet on the temperature control unit - this will ensure enough back pressure to activate the Safe-Lock safety couplings. See the illustration for details:

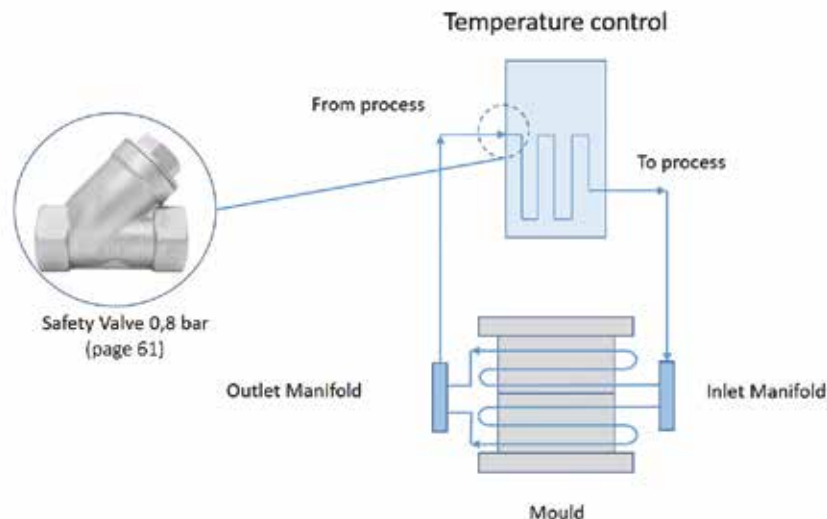

# INTERNATIONAL SERIES

Nominal Diameter

# 20 / 30 / 50

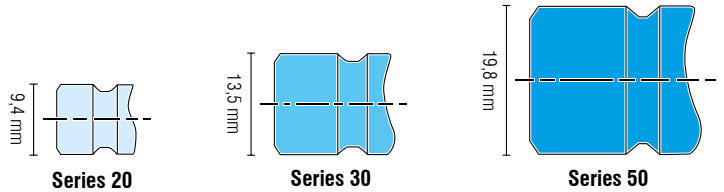

Illustration scale 1:1

## TECHNICAL DESCRIPTION

Coupling series especially developed for connecting coolant lines on injection moulds.

Fully interchangeable with other brands with the same plug profiles.

All dimensions and tolerances according to original specs.

## CHART

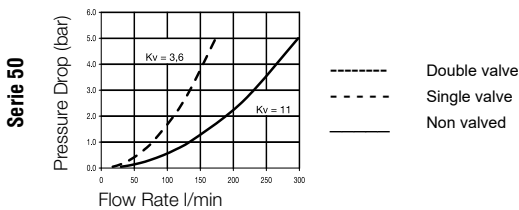
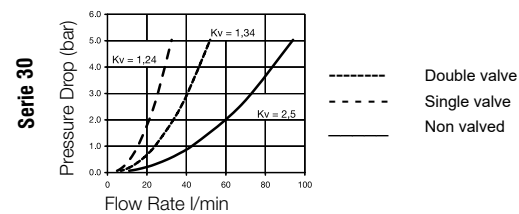
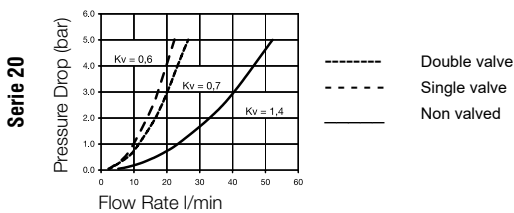

## MATERIAL

### Coupling

Back Body	Brass
Valve Body	Brass
Sleeve	Brass (without Valve)
Sleeve	Brass, Nickel Plated (with Valve)
Valve	Brass
Locking Balls	AISI 420
Spring	AISI 301
Seal	FKM

### Plug

Plug Profile	Brass
Back Body	Brass
Valve	Brass
Spring	AISI 301
Seal	FKM

## WORKING PRESSURE

15 bar, maximum static working pressure with safety factor of 4 to 1.

## WORKING TEMPERATURE

Water -15°C up to +140°C

Oil -15°C up to +180°C

**STRAIGHT COUPLING**

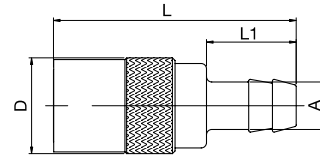

DN	Series	↙	↔	A	D	L	L1	⊠
6	20	20K6V	20K6	6	18	46	17	10
		20K10V	20K10	10	18	51	22	10
9	30	30K10V	30K10	10	24	64	22	10
		30K13V	30K13	13	24	66,5	25	10
16	50	50K19V	50K19	19	32	89	32	5

**SAFE-LOCK™ SAFETY COUPLING**

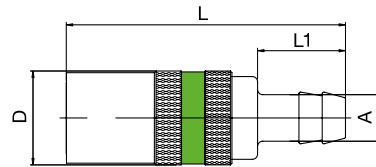

DN	Series	↙	↔	A	D	L	L1	⊠
6	20	20K6V-S	20K6-S	6	18	54	17	10
		20K10V-S	20K10-S	10	18	59	22	10
9	30	30K10V-S	30K10-S	10	24	73	22	10
		30K13V-S	30K13-S	13	24	76	25	10

**PUSH LOCK - STRAIGHT COUPLING**

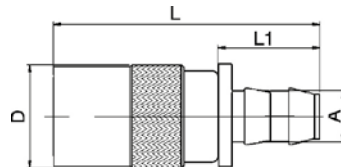

DN	Series	↙	↔	A	D	L	L1	⊠
6	20	20K10V-PL	20K10-PL	10	18	58	28	10
9	30	30K10V-PL	30K10-PL	10	24	64,5	28	10
		30K13V-PL	30K13-PL	13	24	64,5	28	10

**90° COUPLING**

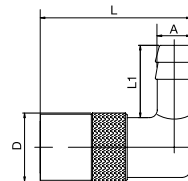

DN	Series	↙	↔	A	D	L	L1	⊠
6	20	20K6/90	20K6/90	6	18	40	19	10
		20K10V/90	20K10/90	10	18	40	22	10
9	30	30K10/90V	30K10/90	10	24	56	22	10
		30K13/90V	30K13/90	13	24	56	28,5	10
16	50	50K19V/90	50K19/90	19	32	77	32	5

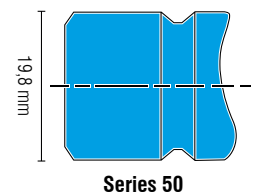
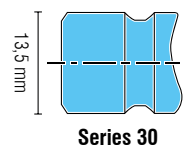
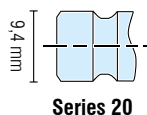

## INTERNATIONAL SERIES

### SAFE-LOCK™ SAFETY COUPLING

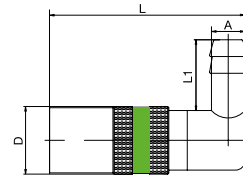

DN	Series	↙	↔	A	D	L	L1	
6	20	20K10V/90-S	20K10/90-S	10	18	52,5	22	10
9	30	30K10V/90-S	30K10/90-S	10	24	68,5	22	10
		30K13V/90-S	30K13/90-S	13	24	68,5	28,5	10

### PUSH LOCK - 90° COUPLING

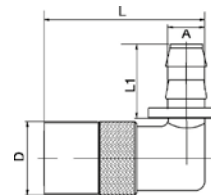

DN	Series	↙	↔	A	D	L	L1	
6	20	20K10V-90-PL	20K10-90-PL	10	18	40,5	28	10
9	30	30K10V-90-PL	30K10-90-PL	10	23	61,5	28	10
		30K13V-90-PL	30K13-90-PL	13	23	61,5	28	10

### 45° COUPLING

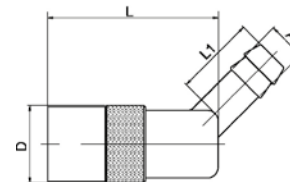

DN	Series	↙	↔	A	D	L	L1	
6	20	20K6V/45	20K6/45	6	18	55,5	19	10
		20K10V/45	20K10/45	10	18	55,5	22	10
9	30	30K10/45V	30K10/45	10	24	71	22	10
		30K13/45V	30K13/45	13	24	75	25	10
16	50	50K19/45V	50K19/45	19	32	77	30	5

### SAFE-LOCK™ SAFETY COUPLING

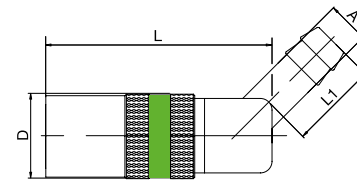

DN	Series	↙	↔	A	D	L	L1	
6	20	20K10V/45-S	20K10/45-S	10	18	51,5	22	10
9	30	30K10V/45-S	30K10/45-S	10	24	65,5	22	10
		30K13V/45-S	30K13/45-S	13	24	65,5	25	10

See explanation of symbols on page 8

**PUSH LOCK - 45° COUPLING**

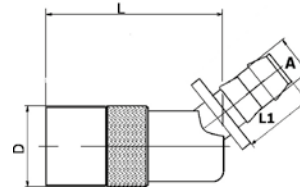

DN	Series	↙	↔	A	D	L	L1	
6	20	20K10V-45-PL	20K10-45-PL	10	18	40,5	28	10
9	30	30K10V-45-PL	30K10-45-PL	10	23	61,5	28	10
		30K13V-45-PL	30K13-45-PL	13	23	61,5	28	10

**MALE THREADED COUPLING**

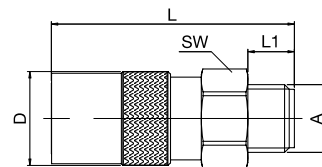

DN	Series	↙	↔	A	D	L	L1	SW	
6	20	20KUR1/4V	20KUR1/4	G1/4	18	47	9	17	10
		20KUR3/8V	20KUR3/8	G3/8	18	47	9	19	10
9	30	30KUR1/4V	30KUR1/4	G1/4	24	56,5	9	22	10
		30KUR3/8V	30KUR3/8	G3/8	24	56,5	9	22	10
		30KUR1/2V	30KUR1/2	G1/2	24	59,5	12	22	10
16	50	50KUR1/2V	50KUR1/2	G1/2	32	73	12	30	10
		50KUR3/4V	50KUR3/4	G3/4	32	77	16	30	5

**SAFE-LOCK™ SAFETY COUPLING**

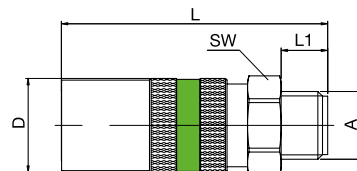

DN	Series	↙	↔	A	D	L	L1	SW	
6	20	20KUR1/4V-S	20KUR1/4-S	G1/4	18	51,5	9	17	10
		20KUR3/8V-S	20KUR3/8-S	G3/8	18	51,5	9	19	10
9	30	30KUR1/4V-S	30KUR1/4-S	G1/4	24	67	9	22	10
		30KUR3/8V-S	30KUR3/8-S	G3/8	24	67	9	22	10
		30KUR1/2V-S	30KUR1/2-S	G1/2	24	70	12	22	10

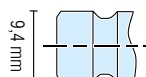

Series 20

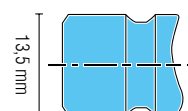

Series 30

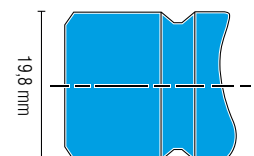

Series 50

## INTERNATIONAL SERIES

### FEMALE THREADED COUPLING

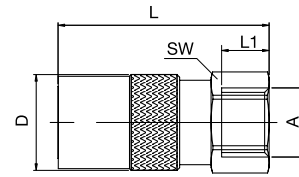

DN	Series	↔	↔	A	D	L	L1	SW	
6	20	20KIR1/8V	20KIR1/8	G1/8	18	40	10	17	10
		20KIR1/4V	20KIR1/4	G1/4	18	40	10	17	10
		20KIR3/8V	20KIR3/8	G3/8	18	44	10	19	10
9	30	30KIR1/4V	30KIR1/4	G1/4	24	51,5	10	21	10
		30KIR3/8V	30KIR3/8	G3/8	24	51,5	10	21	10

### BANJO BRIDGE

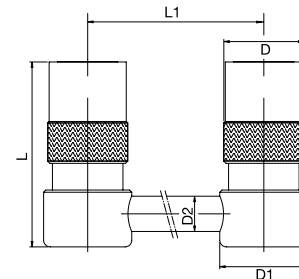

DN	Series	↔	A	D	L	D1	D2	L1	
6	20	20K125		18	42	20	8	125	1
		20K250		18	42	20	8	250	1
		20K500		18	42	20	8	500	1
9	30	30K125		24	58	26	10	125	1
		30K250		24	58	26	10	250	1
		30K500		24	58	26	10	500	1
16	50	50K160		32	78	36	14	160	1
		50K315		32	78	36	14	315	1
		50K500		32	78	36	14	500	1

See explanation of symbols on page 8

**BLIND COUPLING**

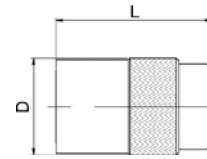

DN	Series		D	L	
6	20	20K	18	30	10
9	30	30K	24	37	10

**MALE PLUG**

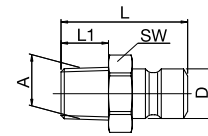

DN	Series		A	D	L	L1	SW	
6	20	20NM10	M10x1	9,4	23	8	13	25
		20NR1/8	R1/8	9,4	24	9	13	25
		20NR1/4	R1/4	9,4	29	12	16	25
		20NR1/4V	R1/4	9,4	29	14	16	25
		20NR3/8	R3/8	9,4	30	12	19	25
9	30	30NR1/8	R1/8	13,5	29,5	20,5	14	25
		30NR1/4V	R1/4	13,5	34	12	16	25
		30NR3/8V	R3/8	13,5	34	12	19	25
		30NR1/2	R1/2	13,5	39	17	24	10
16	50	50NR1/2	R1/2	19,8	44	17	22	10
		50NR3/4	R3/4	19,8	45	19	29	10

**ADJUSTABLE PLUG**

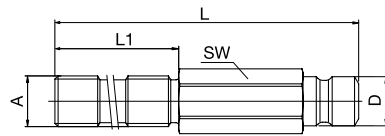

DN	Series		A	D	L	L1	SW	
6	20	20NR1/8/100	G1/8	9,4	100	60	11	10
		20NR1/4/100	G1/4	9,4	100	60	14	10
9	30	30NR1/4/100	G1/4	13,5	100	60	14	10
		30NR3/8/100	G3/8	13,5	100	60	17	10

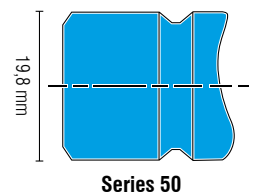
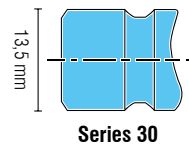
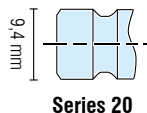

# INTERNATIONAL SERIES

## EXTENDED PLUG

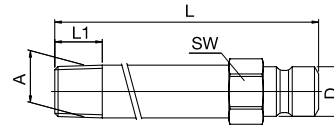

DN	Series	↔	A	D	L	L1	SW	📦
6	20	20N50	R1/8	9,4	50	9	11	10
		20N50-1/4	R1/4	9,4	50	12	14	10
		20N100	R1/8	9,4	100	9	11	10
		20N100-1/4	R1/4	9,4	100	12	14	10
		20N150	R1/8	9,4	150	9	11	10
		20N150-1/4	R1/4	9,4	150	12	14	10
		20N200	R1/8	9,4	200	9	11	10
		20N200-1/4	R1/4	9,4	200	12	14	10
		20N250	R1/8	9,4	250	9	11	10
		20N250-1/4	R1/4	9,4	250	12	14	10
9	30	30N50	R1/4	13,5	50	12	15	10
		30N100	R1/4	13,5	100	12	15	10
		30N150	R1/4	13,5	150	12	15	10
		30N200	R1/4	13,5	200	12	15	10
		30N250	R1/4	13,5	250	12	15	10

## 90° MALE PLUG

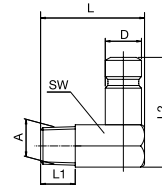

DN	Series	↔	A	D	L	L1	L2	SW	📦
6	20	20NM10/90	M10x1	9,4	27	9	28,5	11	25
		20NR1/8/90	R1/8	9,4	27	9	28,5	11	25
		20NR1/4/90	R1/4	9,4	27	9	28,5	11	25
9	30	30NR1/4/90	R1/4	13,5	34	9	32	15	25
		30NR3/8/90	R3/8	13,5	34	9	32	15	25

## HOSETAIL PLUG

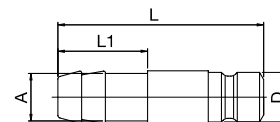

DN	Series	↔	A	D	L	L1	📦
6	20	20N10	10	9,4	39	22	25
9	30	30N13	13	13,5	41	21	25
16	50	50N19	19	20	50	28	10

See explanation of symbols on page 8



**PUSH LOCK - HOSETAIL PLUG**

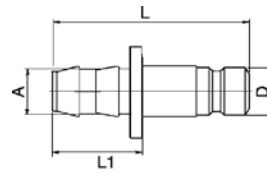

DN	Series		A	D	L	L1	
6	20	20N10-PL	10	9,4	44	28	10
9	30	30N10-PL	10	13,5	44	28	10
		30N13-PL	13	13,5	44	28	10

**FEMALE PLUG**

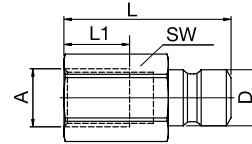

DN	Series		A	D	L	L1	SW	
6	20	20NR1/8I	G1/8	9,4	28	11	13	25
		20NR1/4I	G1/4	9,4	32	13	16	25
		20NR3/8I	G3/8	9,4	34	13	19	25
9	30	30NR1/4I	G1/4	13,5	37	13	16	25
		30NR3/8I	G3/8	13,5	39	13	19	25

**REPLACEMENT SEALS FKM**

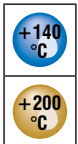

Part No.	Series	S	
200V	20	6	10
300V	30	9	10
500V	50	16	10

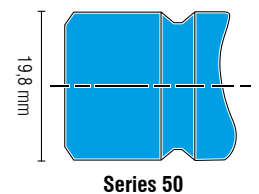
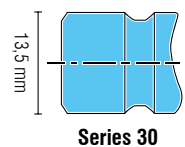
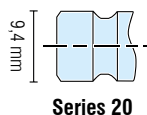

# EUROPEAN SERIES

Nominal Diameter

# 09 / 13 / 19

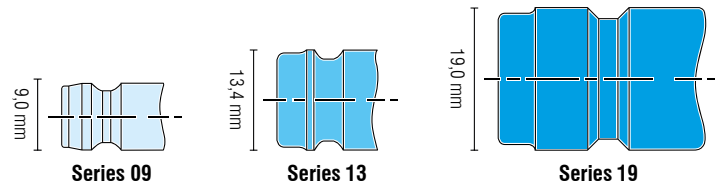

Illustration scale 1:1



## TECHNICAL DESCRIPTION

Coupling series especially developed for connecting coolant lines on injection moulds.

Fully interchangeable with other brands with the same plug profiles.

All dimensions and tolerances according to original specs.

## CHART

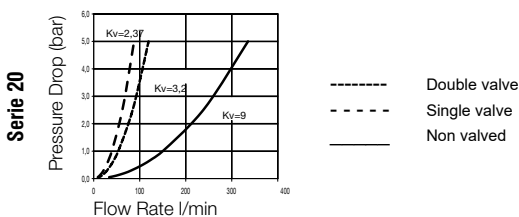
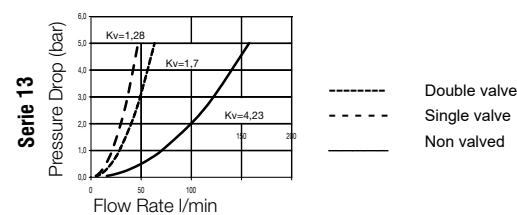
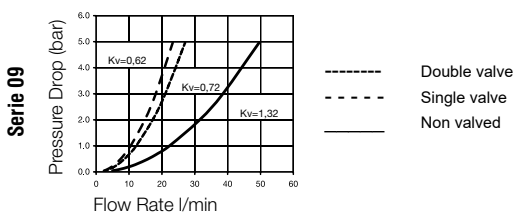

## MATERIAL

### Coupling

Back Body	Brass
Valve Body	Brass
Sleeve	Brass (with valve)
Sleeve	Brass, Nickel Plated (without valve)
Valve	Brass
Locking balls	AISI 420
Spring	AISI 301
Seal	FKM

### Plug

Plug Profile	Brass
Back Body	Brass
Valve	Brass
Spring	AISI 301
Seal	FKM

## WORKING PRESSURE

15 bar, maximum static working pressure with safety factor of 4 to 1.

## WORKING TEMPERATURE

### Standard Couplers

Water -15°C up to +140°C

Oil -15°C up to +180°C

### HT-Series

Water -15°C up to +180°C

Oil -15°C up to +180°C

**STRAIGHT COUPLING**

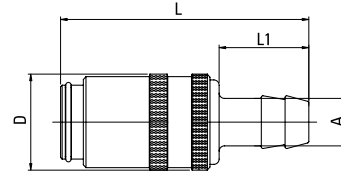

DN	Series	↙	↔	A	D	L	L1	Icon
6	09	09K10V	09K10	10	18	52	22	10
9	13	13K13V	13K13	13	23	61,5	25	10
13	19	19K19V	19K19	19	32	90	32	5

**SAFE-LOCK™ SAFETY COUPLING**

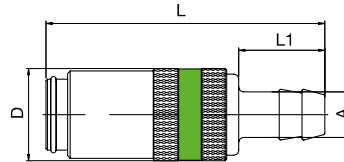

DN	Series	↙	↔	A	D	L	L1	Icon
6	09	09K10V-S	09K10-S	10	18	60	22	10
9	13	13K13V-S	13K13-S	13	24	71	25	10

**SAFE-LOCK™ SAFETY COUPLING**

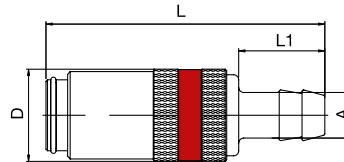

DN	Series	↙	↔	A	D	L	L1	Icon
6	09	09K10V-S-HT	09K10-S-HT	10	18	60	22	10
9	13	13K13V-S-HT	13K13-S-HT	13	24	71	25	10

**PUSH LOCK - STRAIGHT COUPLING**

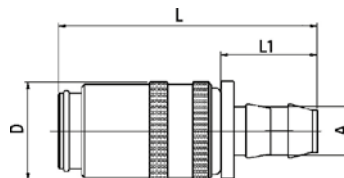

DN	Series	↙	↔	A	D	L	L1	Icon
6	09	09K10V-PL	09K10-PL	10	18	58,5	28	10
9	13	13K13V-PL	13K13-PL	13	23	64,5	28	10

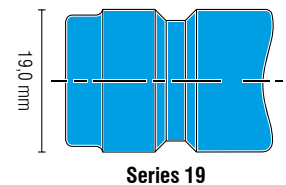
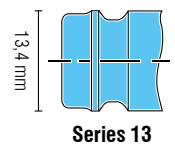
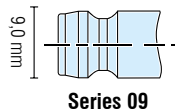

## EUROPEAN SERIES

### 90° COUPLING

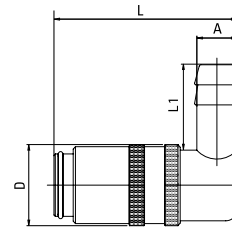

DN	Series			A	D	L	L1	
6	09	09K10V-90	09K10-90	10	18	41	22	10
9	13	13K13V-90	13K13-90	13	23	51	28,5	10
13	19	19K19V-90	19K19-90	19	32	78	32	5

### SAFE-LOCK™ SAFETY COUPLING

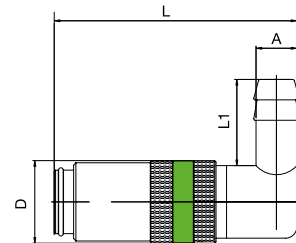

DN	Series			A	D	L	L1	
6	09	09K10V/90-S	09K10/90-S	10	18	53,5	22	10
9	13	13K13V/90-S	13K13/90-S	13	24	63,5	28,5	10

### SAFE-LOCK™ SAFETY COUPLING

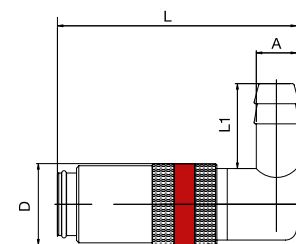

DN	Series			A	D	L	L1	
6	09	09K10V/90-S-HT	09K10/90-S-HT	10	18	53,5	22	10
9	13	13K13V/90-S-HT	13K13/90-S-HT	13	24	63,5	28,5	10

See explanation of symbols on page 8

**PUSH LOCK - 90° COUPLING**

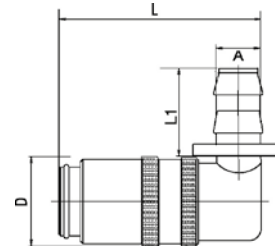

DN	Series	↙↘	↔	A	D	L	L1	📦
6	09	09K10V-90-PL	09K10-90-PL	10	18	42,5	28	10
9	13	13K13V-90-PL	13K13-90-PL	13	23	51	28	10

**45° COUPLING**

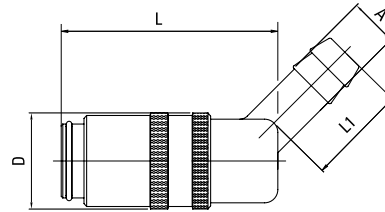

DN	Series	↙↘	↔	A	D	L	L1	📦
6	09	09K10V-45	09K10-45	10	18	41	22	10
9	13	13K13V-45	13K13-45	13	23	51	25	10
13	19	19K19V-45	19K19-45	19	32	78	30	5

**SAFE-LOCK™ SAFETY COUPLING**

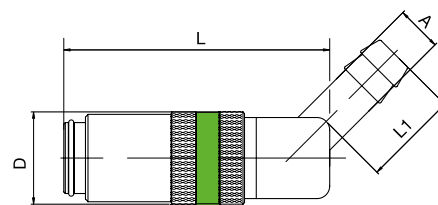

DN	Series	↙↘	↔	A	D	L	L1	📦
6	09	09K10V/45-S	09K10/45-S	10	18	60	22	10
9	13	13K13V/45-S	13K13/45-S	13	24	60,5	25	10

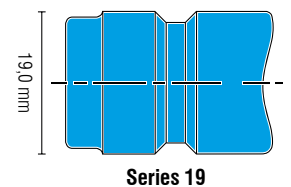
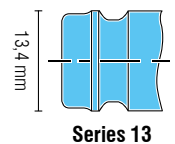
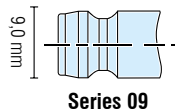

## EUROPEAN SERIES

### SAFE-LOCK™ SAFETY COUPLING

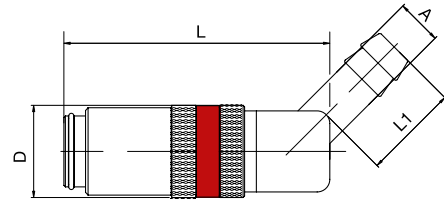

DN	Series	↙↘	↔	A	D	L	L1	📦
6	09	09K10V/45-S-HT	09K10/45-S-HT	10	18	60	22	10
9	13	13K13V/45-S-HT	13K13/45-S-HT	13	24	60,5	25	10

### PUSH LOCK - 45° COUPLING

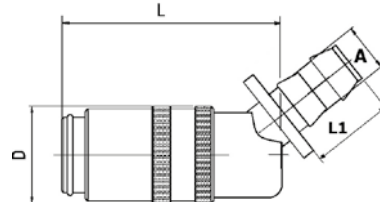

DN	Series	↙↘	↔	A	D	L	L1	📦
6	09	09K10V-45-PL	09K10-45-PL	10	18	42,5	28	10
9	13	13K13V-45-PL	13K13-45-PL	13	23	51	28	10

### MALE THREADED COUPLING

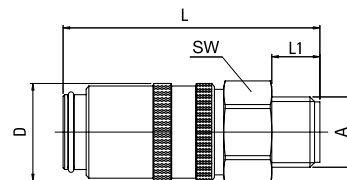

DN	Series	↙↘	↔	A	D	L	L1	SW	📦
6	09	09KUM14V	09KUM14	M14x1,5	18	48	9	17	10
		09KUR1/4V	09KUR1/4	G1/4	18	48	9	17	10
		09KUR3/8V	09KUR3/8	G3/8	18	48	9	19	10
9	13	13KUM16V	13KUM16	M16x1,5	23	51,5	9	22	10
		13KUR1/4V	13KUR1/4	G1/4	23	51,5	9	22	10
		13KUR3/8V	13KUR3/8	G3/8	23	51,5	9	22	10
		13KUR1/2V	13KUR1/2	G1/2	23	54,5	12	22	10
13	19	19KUR1/2V	19KUR1/2	G1/2	32	74	12	30	5
		19KUR3/4V	19KUR3/4	G3/4	32	78	16	30	5

See explanation of symbols on page 8

**MALE THREADED COUPLING, SHORT VERSION**

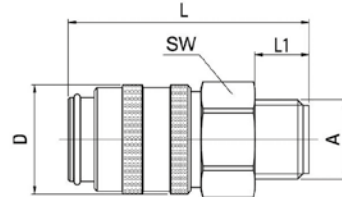

DN	Series	Symbol	A	D	L	L1	SW	VPE	SW	Icon
6	09	09KSR1/4	G 1/4	18	38	9	17	10	17	10
9	13	13KSR3/8	G 3/8	24	38	9	22	10	22	10

**SAFE-LOCK™ SAFETY COUPLING**

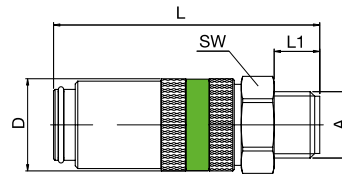

DN	Series	Symbol	Symbol	A	D	L	L1	SW	Icon
6	09	09KUM14V-S	09KUM14-S	M14x1,5	18	52,5	9	17	10
		09KUR1/4V-S	09KUR1/4-S	G1/4	18	52,5	9	17	10
		09KUR3/8V-S	09KUR3/8-S	G3/8	18	52,5	9	19	10
9	13	13KUM16V-S	13KUM16-S	M16x1,5	24	62	9	22	10
		13KUR1/4V-S	13KUR1/4-S	G1/4	24	62	9	22	10
		13KUR3/8V-S	13KUR3/8-S	G3/8	24	62	9	22	10
		13KUR1/2V-S	13KUR1/2-S	G1/2	24	65	12	22	10

**SAFE-LOCK™ SAFETY COUPLING**

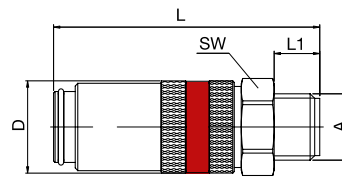

DN	Series	Symbol	Symbol	A	D	L	L1	SW	Icon
6	09	09KUM14V-S-HT	09KUM14-S-HT	M14x1,5	18	52,5	9	17	10
		09KUR1/4V-S-HT	09KUR1/4-S-HT	G1/4	18	52,5	9	17	10
		09KUR3/8V-S-HT	09KUR3/8-S-HT	G3/8	18	52,5	9	19	10
9	13	13KUM16V-S-HT	13KUM16-S-HT	M16x1,5	24	62	9	22	10
		13KUR1/4V-S-HT	13KUR1/4-S-HT	G1/4	24	62	9	22	10
		13KUR3/8V-S-HT	13KUR3/8-S-HT	G3/8	24	62	9	22	10
		13KUR1/2V-S-HT	13KUR1/2-S-HT	G1/2	24	65	12	22	10

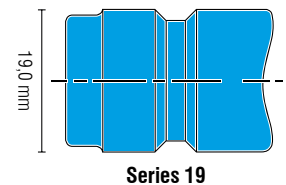
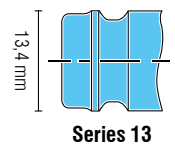
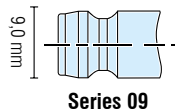

## EUROPEAN SERIES

### FEMALE THREADED COUPLING

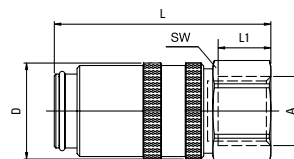

DN	Series			A	D	L	L1	SW	
6	09	09KIR1/4V	09KIR1/4	G1/4	18	41	10	17	10
		09KIR3/8V	09KIR3/8	G3/8	18	45	10	19	10
9	13	13KIR1/4V	13KIR1/4	G1/4	23	46,5	10	21	10
		13KIR3/8V	13KIR3/8	G3/8	23	46,5	10	21	10
		13KIM16V	13KIM16	M16x1,5	23	46,5	10	21	10

### 90° MALE THREADED COUPLING

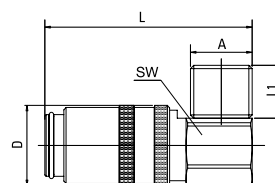

DN	Series			A	D	L	L1	SW	
6	09	09KM14/90V	09KM14/90	M14x1,5	18	47	12	17	10
		09KR1/4/90V	09KR1/4/90	G1/4	18	47	12	17	10
9	13	13KUM16/90V	13KM16/90	M16x1,5	23	53,5	12	22	10

### 45° MALE THREADED COUPLING

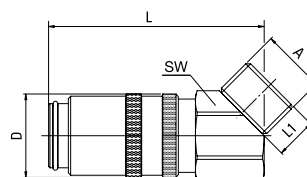

DN	Series			A	D	L	L1	SW	
6	09	09KM14/45V	09KM14/45	M14x1,5	18	47	9	17	10
		09KR1/4/45V	09KR1/4/45	G1/4	18	47	9	17	10
9	13	13KUM16/45V	13KUM16/45	M16x1,5	23	53,5	9	22	10

See explanation of symbols on page 8



**BANJO BRIDGE**

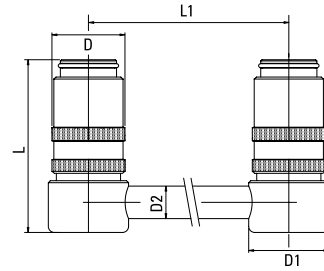

DN	Series		D	L	D1	D2	L1	
6	09	09K125	18	43	20	8	125	1
		09K250	18	43	20	8	250	1
		09K500	18	43	20	8	500	1
9	13	13K125	23	53	26	10	125	1
		13K250	23	53	26	10	250	1
		13K500	23	53	26	10	500	1
13	19	19K160	32	80	36	14	160	1
		19K315	32	80	36	14	315	1
		19K500	32	80	36	14	500	1

**BLIND COUPLING**

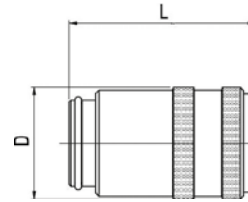

DN	Series		D	L	
6	09	09K	18	30	10
9	13	13K	24	37	10

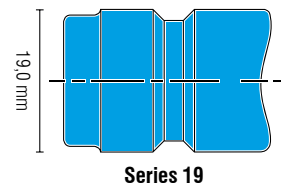
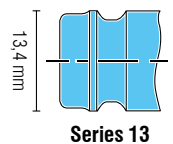
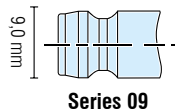

# EUROPEAN SERIES

## MALE PLUG

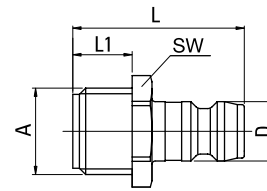

DN	Series	↔	↔	A	D	L	L1	SW	📦
6	09	09NM8	M8x0,75	9	9	24	7	11	25
		09NM10	M10x1	9	9	24	7	11	25
		09NR1/8*	G1/8	9	9	24	7	11	25
		09NM12	M12x1,5	9	9	27	10	14	25
		09NM14	M14x1,5	9	9	26	9	15	25
		09NM14V	M14x1,5	9	9	29	12	15	25
		09NR1/4*	G1/4	9	9	26	9	15	25
		09NR1/4V*	G1/4	9	9	29	12	15	25
9	13	09NR3/8*	G3/8	9	9	30	10	17	25
		13NR1/8*	G1/8	13,4	13,4	25	8	14	25
		13NM14	M14x1,5	13,4	13,4	26	9	15	25
		13NR1/4*	G1/4	13,4	13,4	26	9	15	25
		13NR1/4V*	G1/4	13,4	13,4	31	12	15	25
		13NR3/8*	G3/8	13,4	13,4	26	9	17	25
		13NR3/8V*	G3/8	13,4	13,4	30	12	17	25
13	19	13NM16	M16x1,5	13,4	13,4	26	9	17	25
		13NM16V	M16x1,5	13,4	13,4	30	12	17	25
		19NM24V	M24x1,5	19	19	51	16	27	10
		19NR1/2V*	G1/2	19	19	47	12	22	10
		19NR3/4V*	G3/4	19	19	51	16	27	10

**Description**  
\* Nickel Plating

## MALE PLUG - STAINLESS STEEL

STAINLESS STEEL

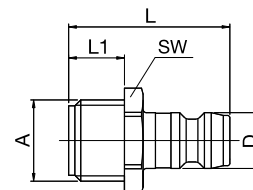

DN	Series	↔	A	D	L	L1	SW	📦	
6	09	09NM8SS	M8x0,75	9	9	24	7	11	25
		09NM10SS	M10x1	9	9	24	7	11	25
		09NR1/8SS	G1/8	9	9	24	7	11	25
		09NR1/4SS	G1/4	9	9	26	9	14	25
9	13	13NR1/4SS	G1/4	13,4	13,4	26	9	14	25
		13NR3/8SS	G3/8	13,4	13,4	26	9	17	25

See explanation of symbols on page 8

**ADJUSTABLE PLUG**

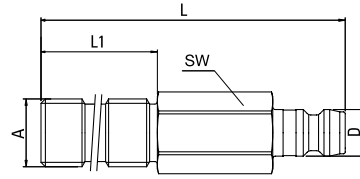

DN	Series		A	D	L	L1	SW	
6	09	09NR1/8/100	G1/8	9	100	60	11	10
		09NR1/4/100	G1/4	9	100	60	14	10
9	13	13NR1/4/100	G1/4	13,4	100	60	14	10
		13NR3/8/100	G3/8	13,4	100	60	19	10

**EXTENDED PLUG**

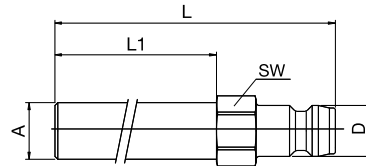

DN	Series		A	D	L	L1	SW	
6	09	09N63	8	9	63	42	9	10
		09N100	8	9	100	79	9	10
		09N120	10	9	120	100	11	10
		09N240	10	9	240	220	11	10
		09N360	10	9	360	340	11	10
9	13	13N150	14	13,4	150	125	15	10
		13N300	14	13,4	300	275	15	10
		13N450	14	13,4	450	425	15	10
13	19	19N500	21	19	500	465	22	5
		19N800	21	19	800	765	22	5

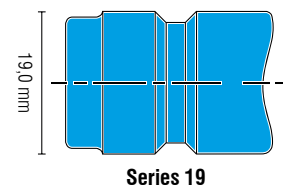
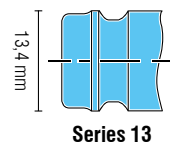
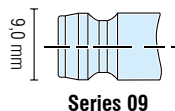

# EUROPEAN SERIES

## EXTENDED PLUG THREADED

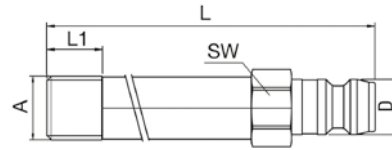

DN	Series	↔	A	D	L	L1	SW	
6	09	09NM10-60	M10X1,5	9	60	9	11	10
		09NM10-100	M10X1,5	9	100	9	11	10
		09NM10-150	M10X1,5	9	150	9	11	10
		09NR1/8-60	R1/8	9	60	9	11	10
		09NR1/8-100	R1/8	9	100	9	11	10
		09NR1/8-150	R1/8	9	150	12	14	10
		09NR1/4-60	R1/4	9	60	12	14	10
		09NR1/4-100	R1/4	9	100	12	14	10
		09NR1/4-150	R1/4	9	150	12	14	10
9	13	13NR1/4-60	R1/4	13,4	60	12	14	10
		13NR1/4-100	R1/4	13,4	100	12	14	10
		13NR1/4-150	R1/4	13,4	150	12	14	10

## 90° MALE PLUG

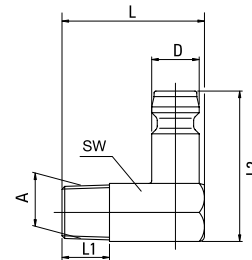

DN	Series	↔	A	D	L	L1	L2	SW	
6	09	09NM8/90	M8x0,75	9	27	9	28,5	11	25
		09NM10/90	M10x1	9	27	9	28,5	11	25
		09NR1/8/90*	R1/8	9	27	9	28,5	11	25
		09NR1/4/90*	R1/4	9	27	9	28,5	11	25
		9	13	13NM14/90	M14x1,5	13,4	34	11	32
13NR1/4/90*	R1/4			13,4	34	11	32	15	25
13NR3/8/90*	R3/8			13,4	34	11	32	15	25
13	19	19NM24/90	M24x1,5	19	47	16	54	24	5
		19NR1/2/90*	R1/2	19	47	16	54	24	5

**Description**  
\* Nickel plated

See explanation of symbols on page 8

**HOSETAIL PLUG**

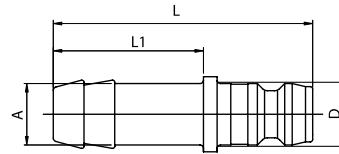

DN	Series	↔	A	D	L	L1	📦
6	09	09N10	10	9	38	22	25
9	13	13N10	10	13,4	41	25	25
		13N13	13	13,4	41	25	25
13	19	19N13	13	19	61	32	5
		19N19	19	19	61	32	5

**PUSH LOCK - HOSETAIL PLUG**

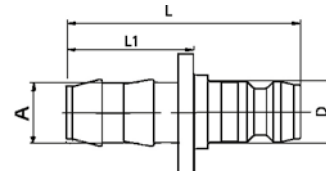

DN	Series	↔	A	D	L	L1	📦
6	09	09N10-PL	10	9	44	28	10
9	13	13N13-PL	13	13,4	44	28	10

**FEMALE PLUG**

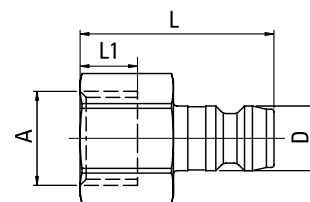

DN	Series	↔	A	D	L	L1	SW	📦
6	09	09NR1/8I*	G1/8	9	24	7	11	25
		09NR1/4I*	G1/4	9	27	8	16	25
9	13	13NR1/4I*	G1/4	13,4	33	8	16	25

**Description**  
\*Nickel Plated

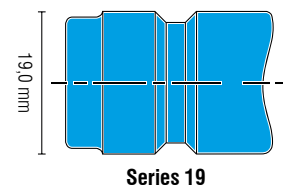
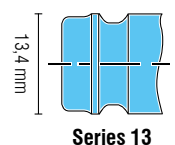
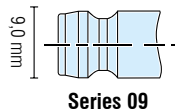

**FRENCH SERIES**

Nominal Diameter

**08 / 12**

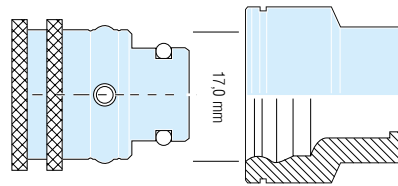

**Series 08**

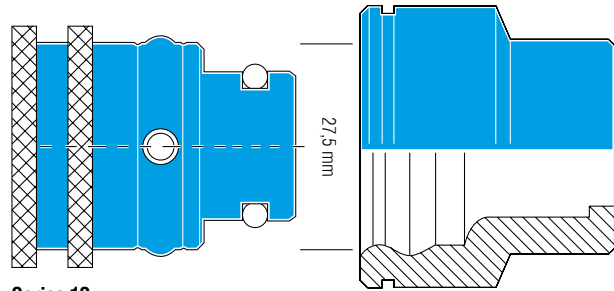

**Series 12**

Illustration scale 1:1



**TECHNICAL DESCRIPTION**

Coupling series especially developed for connecting coolant lines on injection moulds.

Fully interchangeable with other brands with same plug profiles.

All dimensions and tolerances are made according to original specs.

**CHART**

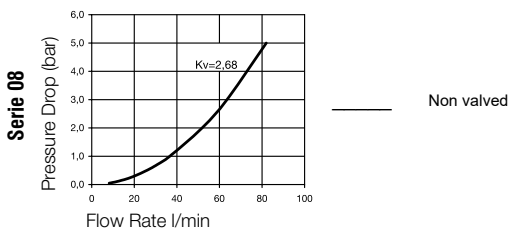

Non valved

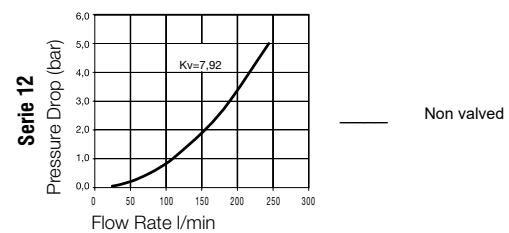

Non valved

**MATERIAL**

Coupling		Plug	
Body	Brass, Nickel Plated	Plug	Brass, Nickel Plated
Locking Balls	AISI 420		
Spring	AISI 301		
Seal	FKM		

**WORKING PRESSURE**

15 bar, maximum static working pressure with safety factor of 4 to 1.

**WORKING TEMPERATURE**

Water -15°C up to +140°C

Oil -15°C up to +180°C

**STRAIGHT COUPLING**

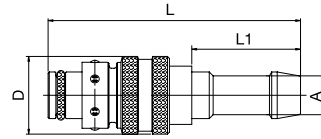

DN	Series	↔	A	D	L	L1	📦
8	08	08K8	8	20	65	28	10
		08K10	10	20	65	28	10
		08K12	13	20	65	28	10
12	12	12K13	13	28	77	33	10
		12K16	16	28	77	33	10

**STRAIGHT COUPLING - PUSH LOCK**

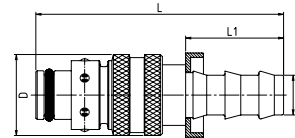
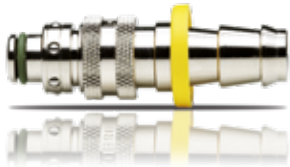

DN	Series	↔	A	D	L	L1	📦
8	08	08K10-PL	10	20	61,5	24,5	10
		08K12-PL	13	20	65	28	10
12	12	12K13-PL	13	28	77	33	10

**90° COUPLING**

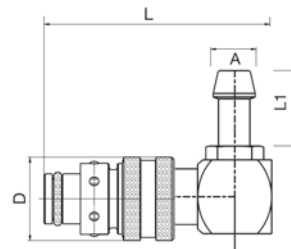
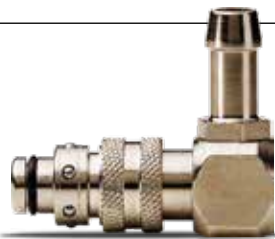

DN	Series	↔	A	D	L	L1	📦
8	08	08K10/90	10	20	51	20	10
		08K12/90	13	20	51	20	10
12	12	12K13/90	13	28	59	25	10
		12K16/90	13	28	62	25	10

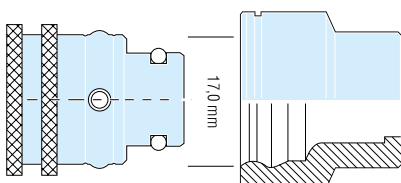

Series 08

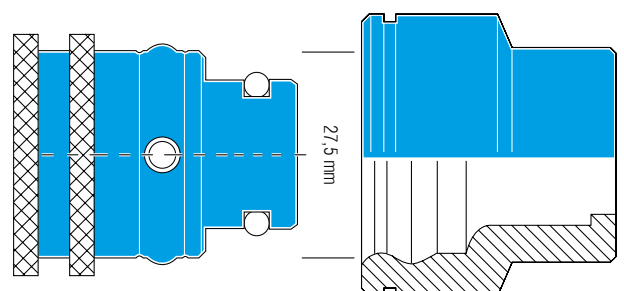

Series 12

## FRENCH SERIES

### 90° COUPLING - PUSH LOCK

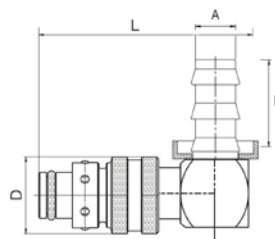
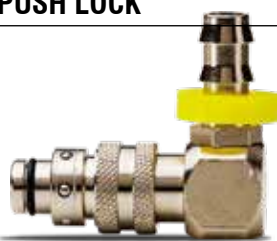

DN	Series	↔	A	D	L	L1	☐
8	08	08K10/90-PL	10	20	51	20	10
		08K12/90-PL	13	20	51	20	10
12	12	12K13/90-PL	13	28	59	25	10
		12K16/90-PL	13	28	62	25	10

### 45° COUPLING

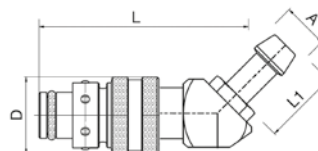

DN	Series	↔	A	D	L	L1	☐
8	08	08K10/45	10	20	51	20	10
		08K12/45	13	20	51	20	10
12	12	12K13/45	13	28	55	25	5
		12K16/45	13	28	55	25	5

### 45° COUPLING - PUSH LOCK

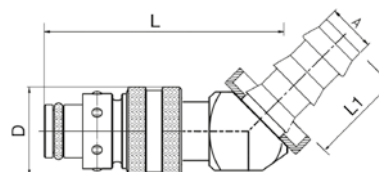
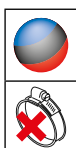

DN	Series	↔	A	D	L	L1	☐
8	08	08K10/45-PL	10	20	51	20	10
		08K12/45-PL	13	20	51	20	10
12	12	12K13/45-PL	13	28	55	25	5
		12K16/45-PL	13	28	55	25	5

☐ See explanation of symbols on page 8



**FEMALE THREADED COUPLING**

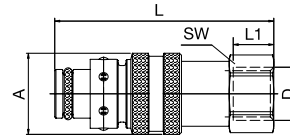

DN	Series	↔	A	D	L	L1	SW	Icon
8	08	08KIR1/4	20	G1/4	43	15	10	10
12	12	12KIR1/2	20	G1/2	60	20	10	10

**MALE PLUG**

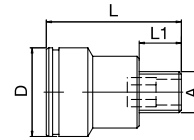

DN	Series	↔	A	D	L	L1	SW	Icon
8	08	08NM10	M10x1	21	32	10	6	25
		08NR1/8	G1/8	21	32	10	6	25
		08NR1/4	G1/4	21	33	12	8	25
		08NR3/8	G3/8	21	24	13	8	25
12	12	12NR3/8	G3/8	32	41	13	10	10
		12NR1/2	G1/2	32	44	16	14	10
		12NR3/4	G3/4	32	32	19	14	10

**FEMALE PLUG**

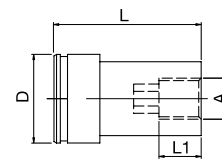

DN	Series	↔	A	D	L	L1	SW	Icon
8	08	08NR1/8I	G1/8	21	35	10	6	10
		08NR1/4I	G1/4	21	40	14	8	10
12	12	12NR3/8I	G3/8	32	49	14	12	10
		12NR1/2I	G1/2	32	50	14	12	10

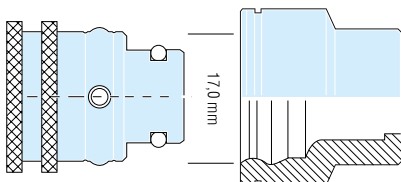

Series 08

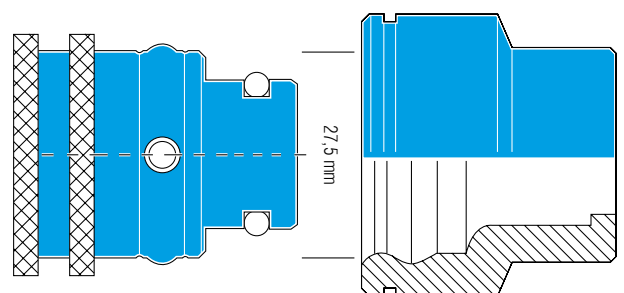

Series 12

## FRENCH SERIES

### 90° PLUG

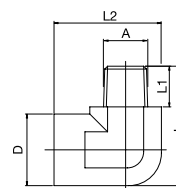

DN	Series	↔	A	D	L	L1	L2	📦
8	08	08NR1/8/90	R1/8	22	34	11	33	10
		08NR1/4/90	R1/4	22	37	13	33	10
		08NR3/8/90	R3/8	22	37	13	33	10

### 45° PLUG

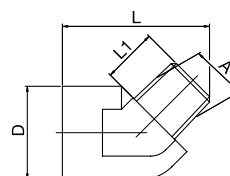

DN	Series	↔	A	D	L	L1	L2	📦
8	08	08NR1/8/45	R1/8	22	33	10,5		10
		08NR1/4/45	R1/4	22	33	10,5		10

### EXTENDED PLUG

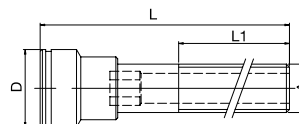

DN	Series	↔	A	D	L	L1	SW	📦
8	08	08NR1/8/50	G1/8	21	50	28	6	10
		08NR1/8/100	G1/8	21	100	60	6	10
		08NR1/8/150	G1/8	21	150	60	6	10
		08NR1/4/50	G1/4	21	50	28	8	10
		08NR1/4/100	G1/4	21	100	60	8	10
		08NR1/4/150	G1/4	21	150	60	8	10
		08NR1/4/200	G1/4	21	200	60	8	10

See explanation of symbols on page 8

**COUPLING COLOUR TAGS**

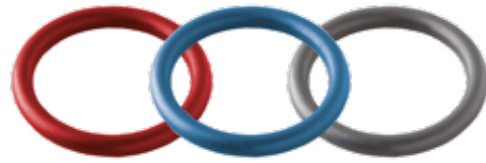

	Series	Part No.	Colour	
Colour Clip for couplers	08	08KR		10
Colour Clip for couplers		08KB		10
Colour Clip for couplers		08KS		10
Colour Clip for couplers	12	12KR		10
Colour Clip for couplers		12KB		10
Colour Clip for couplers		12KS		10

**PLUG COLOUR TAGS**



	Series	Part No.	Colour	
Colour Clip for connectors	08	08NR		10
Colour Clip for connectors		08NB		10
Colour Clip for connectors		08NS		10
Colour Clip for connectors	12	12NR		10
Colour Clip for connectors		12NB		10
Colour Clip for connectors		12NS		10

**REPLACEMENT SEALS FKM +200°C**

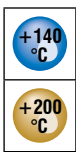

Part No.	Series	S	
08V	08		10
12V	12		10

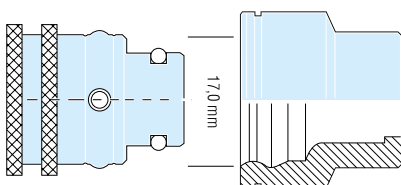

Series 08

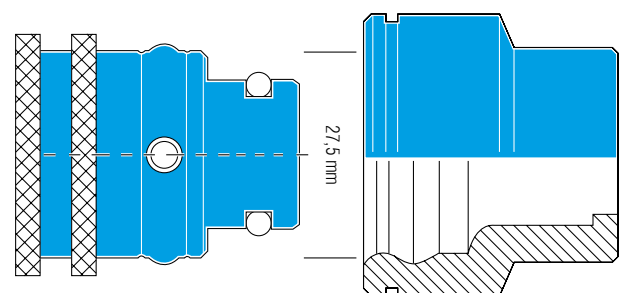

Series 12

# FRENCH MATIC SERIES

Nominal Diameter

# 6 / 9 / 12 / 16 / 25

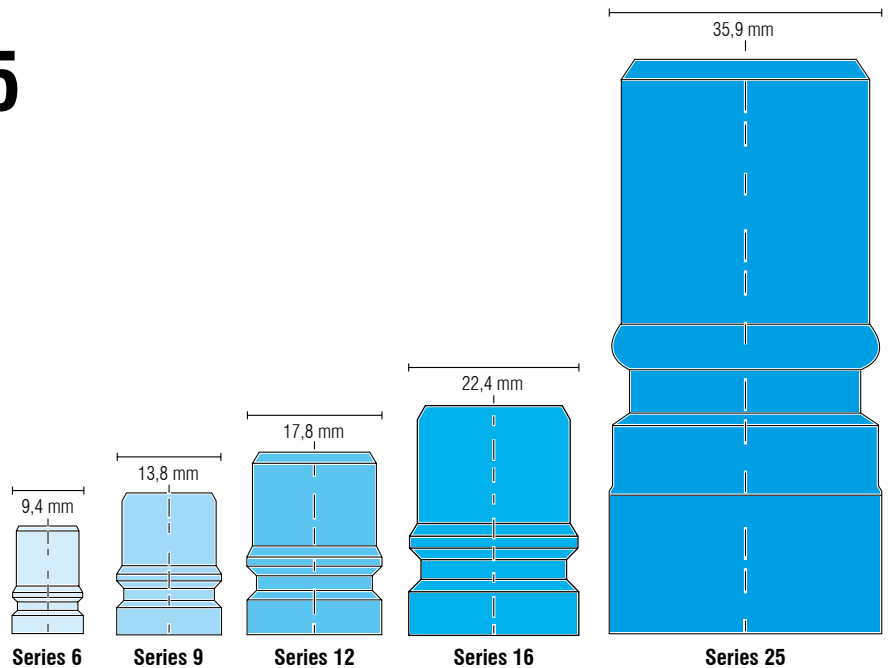

Illustration scale 1:1



## TECHNICAL DESCRIPTION

Coupling series especially developed for connecting coolant lines on injection moulds.

Fully interchangeable with other brands with same plug profiles.

All dimensions and tolerances are made according to original specs.

## CHART

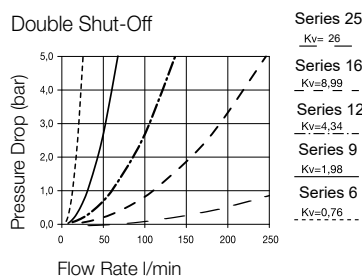
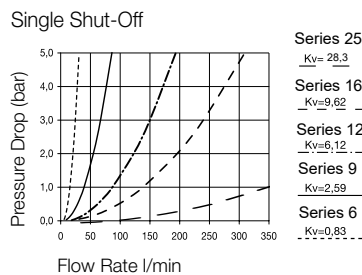

## MATERIAL

### Coupling

Body	Brass, Nickel Plated
Locking Balls	AISI 420
Spring	AISI 301
Seal	FKM

### Plug

Plug Profile	Series 6/9/12	Series 16/25
Back Body	Brass, Nickel Plated	Steel, Zinc Plated
Valve	Brass	Brass, Nickel Plated
Spring	Brass	Brass
Series 6/9/12	AISI 301	AISI 301
Series 16/25	FKM	FKM

## WORKING PRESSURE

15 bar, maximum static working pressure with safety factor of 4 to 1.

## WORKING TEMPERATURE

Water -15°C up to +140°C

**STRAIGHT COUPLING**

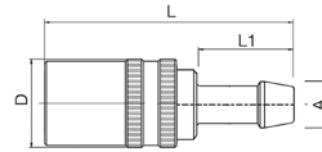

DN	Series	Symbol	A	D	L	L1	Box
6	6	F6K8V	8	20	58	22	10
9	9	F9K12V	12	24	71	25	10
12	12	F12K16V	16	32	90,5	32	10
16	16	F16K19V	19	38	112,5	36	5

**MALE THREADED COUPLING**

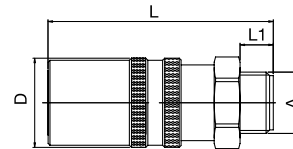

DN	Series	Symbol	A	D	L	L1	Box
6	6	F6KUR1/4V	G 1/4	20	54	9	10
9	9	F9KUR3/8V	G 3/8	24	61,0	9	10
12	12	F12KUR1/2V	G 1/2	32	74,5	12	10
16	16	F16KUR3/4V	G 3/4	38	90,5	16	5
25	25	F25KUR1/1V	G 1	60	144	20	1
		F25KUR1-1/4V	G 1-1/4	60	144	21	1

**90° COUPLING**

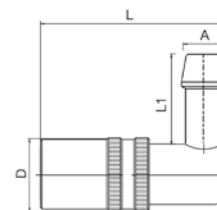
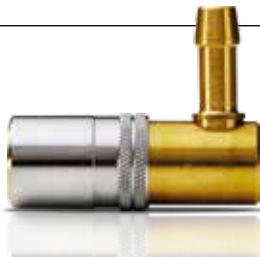

DN	Series	Symbol	A	D	L	L1	Box
6	6	F6K8V/90	8	20	60,5	22	10
9	9	F9K10V/90	10	24	60,5	22	10
		F9K12V/90	12	24	60,5	28,5	10

# FRENCH MATIC SERIES

## FEMALE THREADED COUPLING

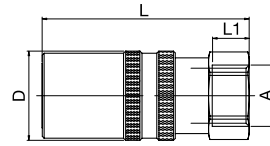

DN	Series	Symbol	A	D	L	L1	Icon
6	6	F6KIR1/4V	20	47	10	G 1/4	10
9	9	F9KIR3/8V	24	56	10	G 3/8	10
12	12	F12KIR1/2V	32	59,5	12	G 1/2	10
16	16	F16KIR3/4V	38	90,5	16	G 3/4	5
25	25	F25KIR1/1V	G 1	60	140	20	1
		F25KIR1-1/4V	G 1-1/4	60	140	21	1

## VALVED PLUG

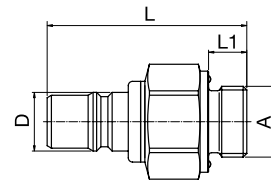

DN	Series	Symbol	A	D	L	L1	HEX	Icon
6	6	F6NR1/8V	G 1/8	9,4	45	7	17	10
9	9	F9NR1/4V	G 1/4	13,8	49	9	19	10
	9	F9NR3/8V	G 3/8	13,8	47	9	24	10
	9	F9NR1/2V	G 1/2	13,8	50	12	27	10
12	12	F12NR3/8V	G 3/8	17,8	61	9	24	10
	12	F12NR1/2V	G 1/2	17,8	62	12	27	10
	12	F12NR3/4V	G 3/4	17,8	64	16	32	10
16	16	F16NR3/4V	G 3/4	22,4	81	16	34	5
	16	F16NR1/1V	G 1	22,4	84	19	41	5
25	25	F25NR1/1V	G 1	36	127	20	50	1
	25	F25NR1-1/4V	G 1 1/4	36	131,5	20	50	1

## VALVED PLUG TAPER THREAD

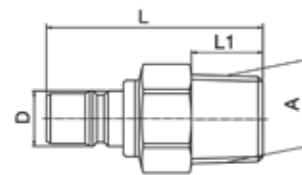

DN	Series	Symbol	A	D	L	L1	HEX	Icon
6	6	F6NT1/8V	1/8	9,4	45	9	17	10
	6	F6NT1/4V	1/4	9,4	46	13	17	10
9	9	F9NT1/4V	1/4	13,8	52	13	19	10
	9	F9NT3/8V	3/8	13,8	52,5	13	19	10
12	12	F12NT3/8V	3/8	17,8	64,5	13	24	10
	12	F12NT1/2V	1/2	17,8	61	15	24	10
16	16	F16NT3/4V	3/4	22,4	78	16	32	5

See explanation of symbols on page 8

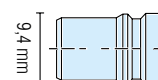

Series 6

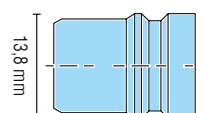

Series 9

**MALE PLUG WITH INNER HEX**

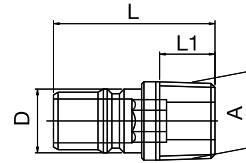

DN	Series	↔	A	D	L	L1	HEX	⊠
6	6	F6NR1/8	R 1/8	10	30	9	5	10
9	9	F9NR1/4	R 1/4	13,8	35	12	8	10
12	12	F9NR3/8	R 3/8	13,8	35	12	8	10
12	12	F12NR3/8	R 3/8	17,8	40	12	10	10

**MALE PLUG TAPER THREAD**

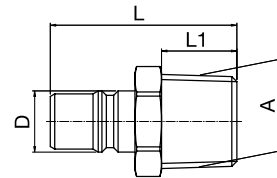

DN	Series	↔	A	D	L	L1	HEX	⊠
12	12	F12NR1/2	R 1/2	17,8	42	17	22	10
16	16	F16NR3/4	R 3/4	22,4	59	19	27	10

**VALVED PLUG SHORT MODEL**

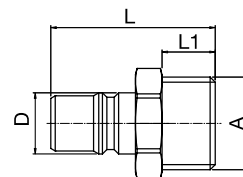

DN	Series	↔	A	D	L	L1	HEX	⊠
9	9	F9NR1/2V-S	G 1/2	13,8	37	12	22	10
12	12	F12NR3/4V-S	G 3/4	17,8	46	16	27	10

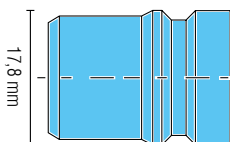

Series 12

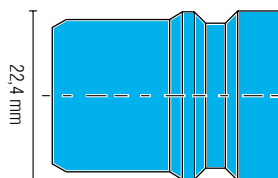

Series 16

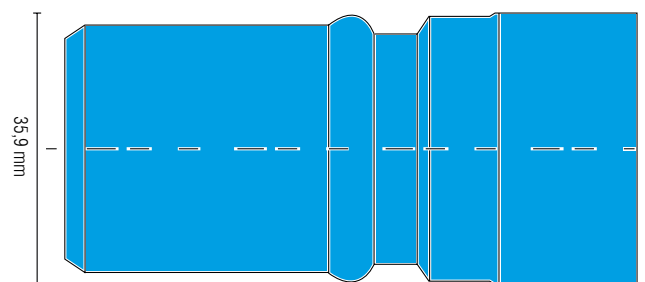

Series 25

## FRENCH MATIC SERIES

### MALE PLUG

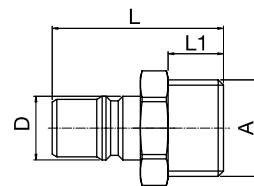

DN	Series		A	D	L	L1	HEX	
9	9	F9NR1/2	G 1/2	13,8	37	12	22	10
12	12	F12NR3/4	G 3/4	17,8	46	16	27	10

### FEMALE PLUG

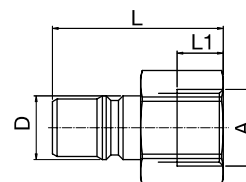

DN	Series		A	D	L	L1	HEX	
6	6	F6NR1/4I	G 1/4	9,4	34	11	17	10
9	9	F9NR3/8I	G 3/8	13,8	37	10	22	10
12	12	F12NR1/2I	G 1/2	17,8	45	12	27	10
25	25	F25NR1/1I	G 1	36	100	20	41	1

### FEMALE PLUG VALVED

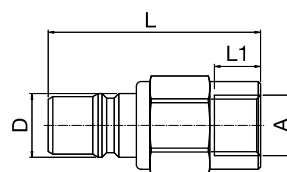

DN	Series		A	D	L	L1	HEX	
9	9	F9NR1/4VI	G 1/4	13,8	46	10	19	10
		F9NR3/8VI	G 3/8	13,8	48	10	22	10
16	16	F16NR3/4VI	G 3/4	22,4	80,5	16	32	5
25	25	F25NR1/1VI	G 1	36	148,5	20	50	1
		F25NR1-1/4VI	G 1-1/4	36	158	20	50	1

See explanation of symbols on page 8





**Quick and safe mould changes with Mouldpro Multi Couplings**

Moulds with many cooling connections can be time consuming and may lead to incorrect connections. With Mouldpro Multi Couplings you can connect all connection in one single operation and eliminate any incorrect connections.

**COUPLING PLATE (MACHINE PLATE)**

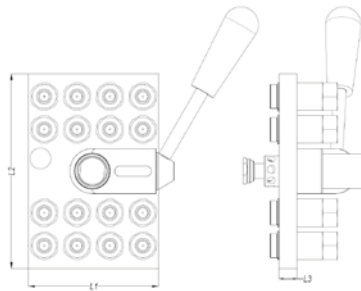

Part No.	# Circuits	# Connections	L1	L2	L3	
MC4	4	8	102	104	14	1
MC6	6	12	154	78	14	1
MC8	8	16	154	104	14	1
MC10	10	20	206	104	14	1
MC12	12	24	240	104	14	1

**Description**  
Supplied without couplings (order separately)

**COUPLINGS FOR MACHINE PLATE**



Connection	Part No.	Part No.	Part No.
Ø 10	MC-C10	MC-C10P	
Ø 13	MC-C13	MC-C13P	
G3/8"			MC-C3/8

**Description**  
Locking rings included.  
Couplers are with shut off valves and 9 mm. flow capacity.

## MULTI COUPLINGS

### COUPLING PLATE - WITH INLET AND OUTLET FEMALE COLLECTOR

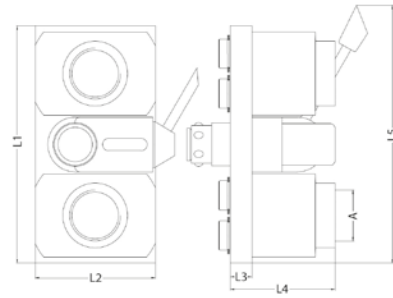

Part No.	# Circuits	# Connection	A	L1	L2	L3	
MC6-1	6	12	G1"	154	78	14	1
MC10-1-1/4	10	20	G1-1/4"	206	103	14	1
MC12-1-1/4	12	24	G1-1/4"	230	103	14	1

### CONNECTION PLATE (MOULD PLATE)

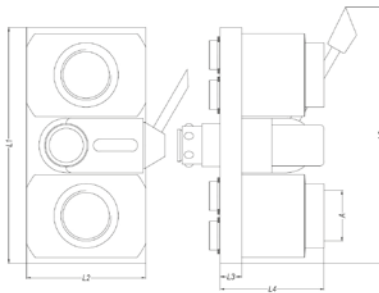

Part No.	# Circuits	# Connections	L1	L2	L3	L4	
MM4-P	4	8	140	104	14	60	1
MM6-P	6	12	190	88	14	60	1
MM8-P	8	16	190	110	14	60	1
MM10-P	10	20	206	110	14	90	1
MM12-P	12	24	256	110	14	90	1

**Description**  
Supplied without Nipples

### NIPPLES FOR MOULD PLATE



Connection	Part No.	Part No.	Part No.	Part No.
Ø 10			NC-C10	NC-C10P
Ø 13			NC-C13	NC-C13P
G3/8"	NC-C3/8V	NC-C3/8		

**Description**  
Locking rings included.  
Nipples are with size 9 mm. flow capacity.

See explanation of symbols on page 8

**Hose Selection Guide**

Mouldpro Hoses are specially engineered for Mould Cooling applications. We offer a wide range of hoses suitable to match any need for the perfect cooling circuit.

Our hoses are available in most common sizes and in 3 main colours to create logic circuits easy to identify cold and warm transfer connections.

We recommend using Stainless steel crimp ferules which allow you to make profesional and safe assemblies.

If you require certified hose assemblies then visit our online configurator at [www.hoseconfigurator.net](http://www.hoseconfigurator.net).



Type	Water	Oil	Working Temperature	Wear Resistance	Chemical Resistance	Pressure Resistance	Flexibility
PVC	✓✓✓	✓	60°C	✓✓	✓✓	✓✓	✓
Push Lok	✓✓✓	✓	90°C	✓✓✓	✓✓	✓✓	✓✓
G - EPDM	✓✓✓	✓	100°C	✓	✓	✓✓	✓✓
NBR	✓	✓✓✓	135°C	✓✓	✓✓✓	✓✓✓	✓✓
E - EPDM	✓✓✓	✓	140°C	✓	✓	✓✓	✓✓
Silicone + SS	✓✓	✓	170°C	✓✓✓	✓	✓✓	✓✓✓
FKM + SS	✓	✓✓✓	200°C	✓✓✓	✓✓✓	✓✓	✓✓
PTFE + SS	✓✓✓	✓✓✓	260°C	✓✓✓	✓✓✓	✓✓✓	✓✓✓

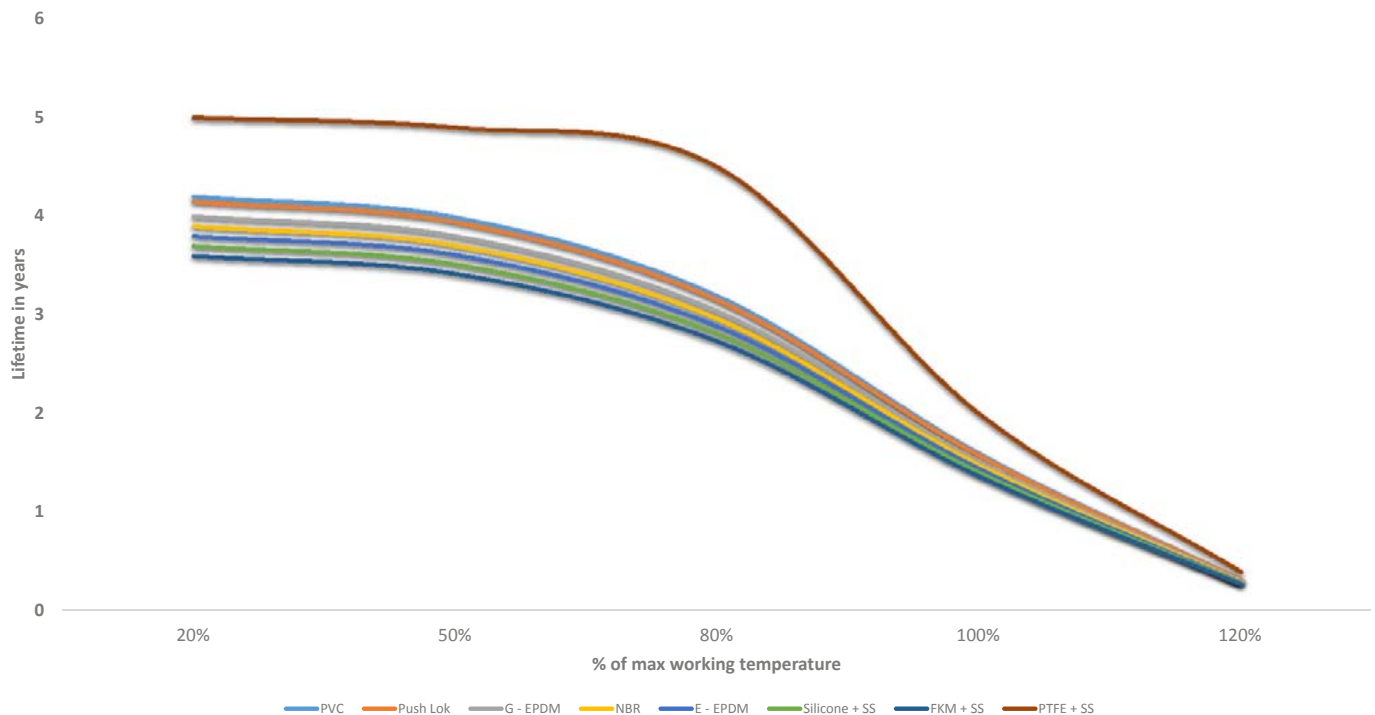

Above figures are only theoretical data, the physical properties are influenced by several factors such as: Pressure, ambient temperatures, wear, additives, sunlight, movement action, bending radius, connection clamping etc. So an individual calculation of lifetime must be based on all variables.

# HOSES

## MATERIAL EPDM

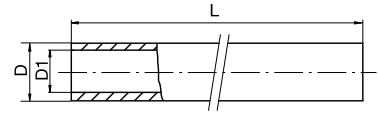
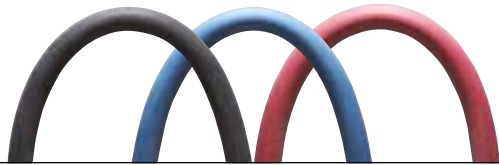
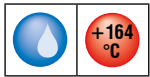

Part No.	D1	D	L (m)	Colour	Working Pressure (Bar)	Burst Pressure (Bar)	Bend Radius	
E10B	10	16,5	50	●	15	60	60	1
E10R	10	16,5	50	●	15	60	60	1
E10S	10	16,5	50	●	15	60	60	1
E13B	13	21	50	●	15	60	90	1
E13R	13	21	50	●	15	60	90	1
E13S	13	21	50	●	15	60	90	1
E19B	19	27	30	●	15	60	110	1
E19R	19	27	30	●	15	60	110	1
E19S	19	27	30	●	15	60	110	1

**Description**

**Tube:**  
Black, antistatic, smooth EPDM Nitrosamine free rubber compound, resistant to heat, hot water and water vapour.

**Cover:**  
Blue, Red, or Black smooth EPDM Nitrosamine free rubber compound. Resistant to abrasion, ozone, heat, and weather.

**Temperature range:**  
Working temperature: Up to +140°C (+284°F) peak up to +164°C (+327°F)  
Note: Lifetime of this hose will be substantially reduced if operating temperatures exceed +130°C (+266°F).

**Tolerances:**  
UNI EN ISO 1307/97 tolerances for inside diameters up to and including 25 mm.

**Reinforcement:**  
Synthetic textile yarns.

**Applications:**  
Flexible hose designed for hot water and water vapour for mould temperature controlling.

**On inside diameter:**  
for I.D. 5.1 up to 20 mm ± 0.80 mm  
Length tolerance: ± 1%

## MATERIAL EPDM

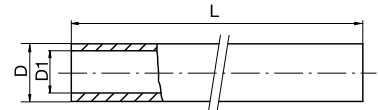
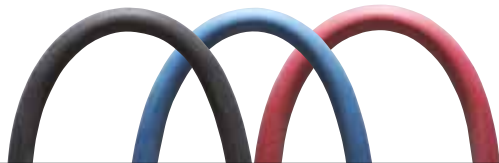
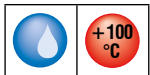

Part No.	D1	D	L (m)	Colour	Working Pressure (Bar)	Burst Pressure (Bar)	Bend Radius	
G10B	10	16,5	50	●	15	60	60	1
G10R	10	16,5	50	●	15	60	60	1
G10S	10	16,5	50	●	15	60	60	1
G13B	13	21	50	●	15	60	90	1
G13R	13	21	50	●	15	60	90	1
G13S	13	21	50	●	15	60	90	1
G19B	19	27	30	●	15	60	110	1
G19R	19	27	30	●	15	60	110	1
G19S	19	27	30	●	15	60	110	1
G25B	25	35	20	●	15	60	130	1
G25R	25	35	20	●	15	60	130	1
G38B	38	48	20	●	10	30	200	1
G38R	38	48	20	●	10	30	200	1

**Description**

**Tube:**  
Black, antistatic, smooth EPDM Nitrosamine free rubber compound, resistant to water, hot water, air, light-chemical media.

**Cover:**  
Red, Blue or Black smooth EPDM Nitrosamine free rubber compound.

**Temperature range:**  
Working temperature: Up to +100°C (+248°F).

**Tolerances:**  
UNI EN ISO 1307/97 tolerances for inside diameters up to and including 25 mm.

**Reinforcement:**  
Synthetic textile yarns.

**Applications:**  
Designed for air, cold and hot water, and light-chemical media for mould temperature controlling.

**On inside diameter:**  
for I.D. 5.1 up to 20 mm ± 0.80 mm  
Length tolerance: ± 1%.

**MATERIAL NBR/PVC - PUSH LOCK HOSE**

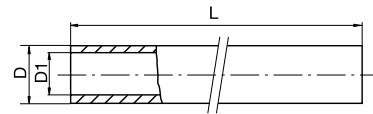
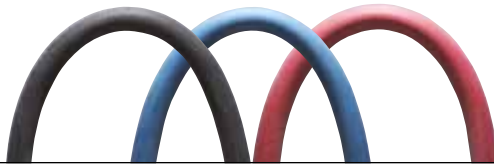
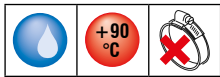

Part No.	D1	D	L (m)	Colour	Working Pressure (Bar)	Burst Pressure (Bar)	Bend Radius	
PL10B	10	16	50	●	12	83	75	1
PL10R	10	16	50	●	12	83	75	1
PL10S	10	16	50	●	12	83	75	1
PL13B	13	20	50	●	12	83	100	1
PL13R	13	20	50	●	12	83	100	1
PL13S	13	20	50	●	12	83	100	1

**Description**

**Tube:**  
NBR/PVC Smooth, low-pressure, "PUSH-LOCK" hydraulic hose. PN3A. Manufactured to CNOMO E07.21.115N, and complies with the stringent pull-off/push-on requirements stated in the standard. For use as air hose on robotic equipment, etc., and for water/oil emulsions both as pressure and return hose. Also available in blue and black.  
Mouldpro Push-Lock fittings are recommended.

**Reinforcement:**  
Polyvinyl alcohol (PVA)

**Temperature range:**  
Up to +90°C (+194°F)

**Tolerances:**  
UNI EN ISO 1307/97 tolerances for inside diameters up to and including 25 mm.

**Cover:**  
NBR/PVC Wear and Oil resistant.

**Applications:**  
Low-Pressure Air, Water and Water/Oil emulsions for mould cooling applications.

**On inside diameter:**  
for I.D. 5.1 up to 20 mm ± 0.80 mm  
Length tolerance: ± 1%  
Standards: CNOMO E07.21.115.N

**MATERIAL NBR**

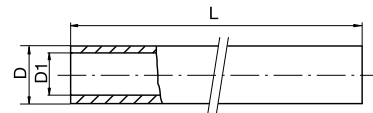
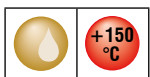

Part No.	D1	D	L (m)	Colour	Working Pressure (Bar)	Burst Pressure (Bar)	Bend Radius	
N10S	10	16.5	50	●	28	110	75	1
N13S	13	20	50	●	28	110	100	1

**Description**

**Tube:**  
Black, antistatic, smooth NBR rubber compound, resistant to Oil.

**Cover:**  
Black smooth CPE rubber compound.

**Temperature range:**  
Working temperature: Up to +135°C (+275°F)  
peak up to +150°C (+302°F)

**Tolerances:**  
UNI EN ISO 1307/97 tolerances for inside diameters up to and including 25 mm.

**Reinforcement:**  
Polyvinyl alcohol (PVA)

**Applications:**  
Designed for Oil mould temperature controlling.

**On inside diameter:**  
for I.D. 5.1 up to 20 mm ± 0.80 mm  
Length tolerance: ± 1%

See explanation of symbols on page 8

# HOSES

## MATERIAL PVC

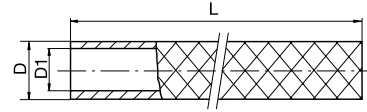
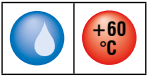

Part No.	D1	D	L (m)	Colour	Working Pressure (Bar)	Burst Pressure (Bar)	Bend Radius	
P10T	10	16	30	○	17	51	65	1
P10B	10	16	30	●	17	51	65	1
P10R	10	16	30	●	17	51	65	1
P13T	13	19	30	○	15	45	85	1
P13B	13	19	30	●	15	45	85	1
P13R	13	19	30	●	15	45	85	1
P19T	19	26	30	○	10	30	125	1
P19B	19	26	30	●	10	30	125	1
P19R	19	26	30	●	10	30	125	1

**Description**

**Tube:**  
Transparent soft PVC hose for low temperature water and air.

**Cover:**  
Clear, blue or red transparent soft PVC. Resistant to abrasion, ozone, and weather.

**Temperature range:**  
Working temperature: Up to +60°C (+140°F) peak up to +90°C (+194°F)  
Note: Lifetime of this hose will be substantially reduced if operating temperatures exceed +60°C (+140°F).

**Tolerances:**  
UNI EN ISO 1307/97 tolerances for inside diameters up to and including 25 mm.

**Reinforcement:**  
High-strength PES fiber.

**Applications:**  
Flexible hose designed for cold water for mould temperature controlling.

**On inside diameter:**  
for I.D. 5.1 up to 20 mm ± 0.80 mm  
Length tolerance: ± 1%

## MATERIAL SILICONE

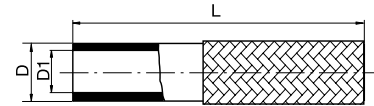
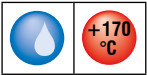

Part No.	D1	D	L (m)	Colour	Working Pressure (Bar)	Burst Pressure (Bar)	Bend Radius	
S10	10	15	25	○	15	45	40	1
S10B	10	15	25	●	15	45	40	1
S10R	10	15	25	●	15	45	40	1
S13	13	19	25	○	15	45	60	1
S13B	13	19	25	●	15	45	60	1
S13R	13	19	25	●	15	45	60	1
S19	19	27	25	○	15	45	100	1

**Description**

**Tube:**  
Clear Silicone Shore 60°.

**Applications:**  
Designed for water and light chemical media for mould temperature controlling.

**Temperature range:**  
Working temperature: Max +170°C / +338°F.

**Tolerances:**  
DIN 7715.

**Reinforcement:**  
Stainless steel overbraid with colour marking made of textile meta aramid. (high temperature resistant)

See explanation of symbols on page 8

**MATERIAL FKM**

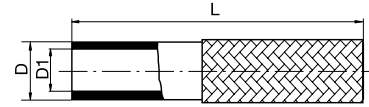

Part No.	D1	D	L (m)	Colour	Working Pressure (Bar)	Burst Pressure (Bar)	Bend Radius	
V10	10	15	25	○	15	45	50	1
V13	13	19	25	○	15	45	60	1

**Description**

**Tube:**  
Black Viton shore 65°.

**Applications:**  
Designed for Oil and chemical media for mould temperature controlling.

**Temperature range:**  
Working temperature: Oil Max +200°C (+392°F)  
Working temperature: Water Max +140°C (+284°F).

**Tolerances:**  
ISO DIN 3302-1 E2.

**Reinforcement:**  
Stainless steel overbraid.

# HOSES

## HIGH TEMPERATURE WATER AND OIL HOSE ASSEMBLIES

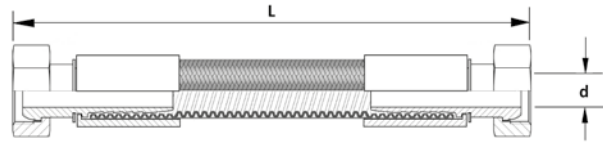

Stainless Steel Braided	Stainless Steel Braided + Red Silicone Jacket	Stainless Steel Braided + Blue Silicone Jacket	A	L	Hose ID	Working Pressure (Bar)	Burst Pressure (Bar)	Bend Radius
T10300R1/4	T10300R1/4-R	T10300R1/4-B	1/4" BSPP	300	10	20	80	22
T10600R1/4	T10600R1/4-R	T10600R1/4-B		600				
T10800R1/4	T10800R1/4-R	T10800R1/4-B		800				
T101000R1/4	T101000R1/4-R	T101000R1/4-B		1000				
T101250R1/4	T101250R1/4-R	T101250R1/4-B		1250				
T101500R1/4	T101500R1/4-R	T101500R1/4-B		1500				
T102000R1/4	T102000R1/4-R	T102000R1/4-B		2000				
T10300M14	T10300M14-R	T10300M14-B	M14x1,5	300	10	20	80	22
T10600M14	T10600M14-R	T10600M14-B		600				
T10800M14	T10800M14-R	T10800M14-B		800				
T101000M14	T101000M14-R	T101000M14-B		1000				
T101250M14	T101250M14-R	T101250M14-B		1250				
T101500M14	T101500M14-R	T101500M14-B		1500				
T102000M14	T102000M14-R	T102000M14-B		2000				
T13300R3/8	T13300R3/8-R	T13300R3/8-B	3/8" BSPP	300	13	20	80	25
T13600R3/8	T13600R3/8-R	T13600R3/8-B		600				
T13800R3/8	T13800R3/8-R	T13800R3/8-B		800				
T131000R3/8	T131000R3/8-R	T131000R3/8-B		1000				
T131250R3/8	T131250R3/8-R	T131250R3/8-B		1250				
T131500R3/8	T131500R3/8-R	T131500R3/8-B		1500				
T132000R3/8	T132000R3/8-R	T132000R3/8-B		2000				

### Description

With 60° Cone Seat swivel fittings DIN 3863.

**Tube:**  
Low profile helically convoluted PTFE (polytetrafluorethylene).

**Reinforcement:**  
Stainless steel overbraid (Red/Blue Silicone cover).

**Applications:**  
Designed for Water, Oil and chemical media for mould temperature controlling.

**Temperature range:**  
Working temperature:  
Max +260°C (+500°F)  
RED/BLUE: Only +200°C (+392°F).

**Tolerances:**  
ISO DIN 3302-1 E2.

See explanation of symbols on page 8



# LEAK FREE HOSE ASSEMBLIES

Order online at: [www.hoseconfigurator.net](http://www.hoseconfigurator.net)



## HOSE PROTECTION

### SAFETY HEAT SLEEVE



Part No.	Colour	ø (ID) mm.	Length
SHS10	●	10	20 m.
SHS10B	●	10	20 m.
SHS15	●	15	20 m.
SHS15B	●	15	20 m.
SHS20	●	20	20 m.
SHS20B	●	20	20 m.
SHS25	●	25	20 m.
SHS25B	●	25	20 m.
SHS30	●	30	20 m.
SHS30B	●	30	20 m.
SHS40	●	40	20 m.
SHS40B	●	40	20 m.

#### Description

Protect hoses and cables from heat exposure  
 Material: Glass fiber with silicone coating  
 Temperature: Up to +260°C continuous heat

### HEAT TAPE



Part No.	Colour	Thickness (mm)	Width (mm)	Roll Length (mm)
HT-B-3	Blue	0,5	25,4	3000
HT-R-3	Red	0,5	25,4	3000

#### Description

Material: Silicone  
 Resists Temps +260°C (+500°F) to -50°C (-60°F)  
 No Adhesive Therefore No Residue when Removed  
 Conforms to Shape to Create an Air and Water Tight Seal  
 Stretches up to 300 %

**SAFETY SLEEVE**



Part No.	∅ (ID) mm	Fiat (mm)	Length (roll)
SS17	17	30	50 m.
SS23	23	40	50 m.
SS30	30	50	50 m.
SS39	39	65	50 m.
SS55	55	90	50 m.

**Description**

Protect in case of burst hose  
 Protect hose from abrasion  
 Resistant to chemicals  
 Polyester up to +120 degrees

**SAFE-STRIP, STANDARD**



Part No.	Length (mm)	Bundel max (mm)	Strip Width (mm)
STD70	310	70	40
STD100	435	100	40
STD125	505	125	40
STD155	605	155	40
STD180	680	180	40

**Description**

Safe-Strip made of polypropylene with Velcro fasteners

**SAFE-STRIP, WITH MOUNTING EYELET**



Part No.	Length (mm)	Bundel max (mm)	Strip Width (mm)
STE70	340	70	40
STE100	455	100	40
STE125	540	125	40
STE155	660	155	40
STE180	765	180	40

**Description**

Safe-Strip made of polypropylene with Velcro fasteners. With Eyelet

**SAFE-STRIP WITH BUCKLE**



Part No.	Length (mm)	Strip Width (mm)
STB50	500	25
STB100	1000	25
STB150	1500	25

**Description**

Safe-Strip made of polypropylene with quick-release buckle

**SAFE-STRIP WITH BUCKLE**



Part No.	Type	Colour	Length	
ZT300R	Date/Year	Red	300 mm.	10
ZT300B	Date/Year	Blue	300 mm.	10
ZT301R	Plain	Red	300 mm.	10
ZT301B	Plain	Blue	300 mm.	10

**Description**

Ziptags available in 2 styles:  
 • With install date marking  
 • Plain for individual marking/labelling

Material: Nylon  
 Temperature range: Up to +150°C

## HOSE CLAMPING

### HOSE CUTTING TOOL



Part No.	Size	
HC025	0-25 mm	1

**Description**  
For PVC and Rubber hoses only

### SPARE BLADES



Part No.	Size	
HC-SB	One Size	1

**FERRULE**

**STAINLESS  
STEEL**

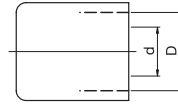

Part No.	D	d		Hose Ref.
C10/15	15,9	10	100	S10
C10/16	16,9	10	100	V10/P10/N10
C10/17	17,5	10	100	G10/E10
C13/19	19	13	100	S13/V13
C13/20	20	13	100	P13
C13/22	22,5	13	100	N13/G13/E13
C19/29	29	19	100	G19/E19

**Description**

Ferrules made of Stainless Steel.  
Offers perfect and safe connections.

**HAND CRIMPER**

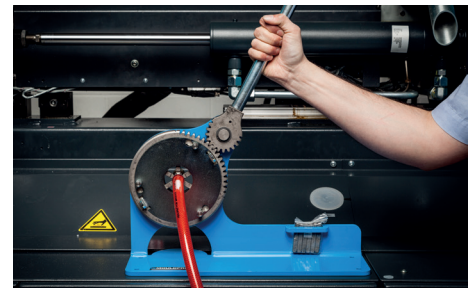

Part No.	Crimp Range (mm)	
X100	10-36	1

**HOSE CLAMPS STANDARD TYPE**

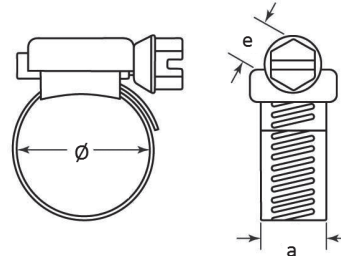

Part No.	Ø	e	a		Hose ref.
K10	11-17	7	9	50	S10/V10/P10/E10/G10/N10
K13	13-20	7	9	50	S13/V13/P13/E13/G13/N13
K19	22-32	7	9	50	S19/P19/E19/G19
K25	32-44	7	9	50	E25/G25

**Description**

Screw: Electro zinc plated. Band: Galvan/Aluzink. Housing: Painted.

# HOSE CLAMPING

## HOSE CLAMPS HEAVY DUTY

STAINLESS  
STEEL

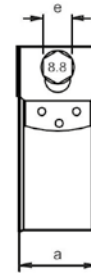
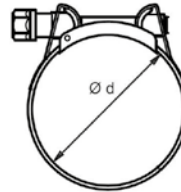

Part No.	Ø	e	a		Hose ref.
HDC2527	25-27	8	18	50	P19/E19/G19
HDC3437	34-37	11	20	50	G25
HDC4751	47-51	11	20	50	G38

**Description**  
Material: Stainless Steel

## FLEXIBLE HOSE CLIP SCREWDRIVER



Part No.	A/F
SD01	7

**Description**  
Flexible screwdriver for hose clips  
7 mm A/F

## SIDE PINCER



Part No.	Side Pincer	Front Pincer	
PS01	•	•	1

**Description**  
Suitable for Ear Clamps  
Can be used either front or side access

## TWO-EAR CLIP

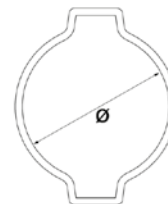

Part No.	Ø - ID	L		HOSE Ref
EAR15	13-15	7	100	S10/V10
EAR17	14-17	7	100	P10/N10
EAR18	15-18	7,5	100	E10/G10
EAR20	17-20	7,5	100	S13/V13/P13/N13
EAR23	20-23	8,5	100	E13/G13
EAR27	23-27	8,5	100	P19
EAR28	25-28	9	100	E19/G19

**Description**  
Two-ear clips are an economical solution for simple hose assemblies. The two ears give the clip extra grip and help to maintain constant pressure around the hose. Two-ear clips offer great versatility in simple hose assemblies.  
Material: St 34 steel : Finish Silver-white Cr3 Zinc-Plated

**STRAIGHT BLADE BAFFLES**

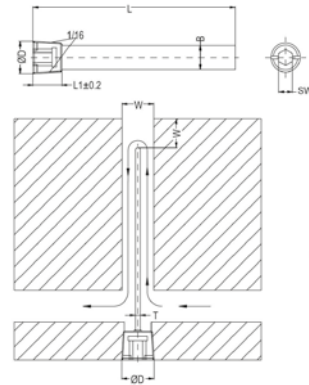
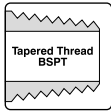

Part No	Thread	SW	W	B	L	L1	T
MB100-1/16	1/16"	4	6,5	6,2	104	8	1,61
MB200-1/16	1/16"	4	6,5	6,2	204	8	1,61
MB100-1/8	1/8"	5	8,5	8,2	104	8	1,61
MB200-1/8	1/8"	5	8,5	8,2	204	8	1,61
MB125-1/4	1/4"	7	11,5	11,2	131	10	2,43
MB250-1/4	1/4"	7	11,5	11,2	258	10	2,43
MB150-3/8	3/8"	8	15	14,2	156	10	2,43
MB300-3/8	3/8"	8	15	14,2	309	10	2,43
MB200-1/2	1/2"	10	18,5	18,2	207	10	2,43
MB400-1/2	1/2"	10	18,5	18,2	410	10	2,43
MB300-3/4	3/4"	12	23,5	23,2	309	12	3,21
MB500-3/4	3/4"	12	23,5	23,2	512	12	3,21

**Description**  
Material: MS58 Brass

**SPIRAL BLADE BAFFLES**

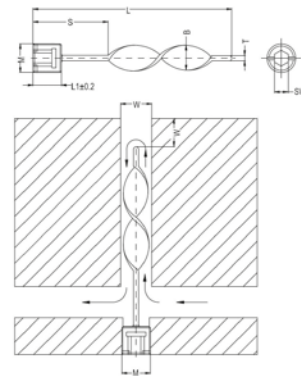
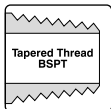

Part No	Thread	S	SW	W	B	L	L1	T
MSB100-1/16	1/16"	51	4	6,5	1/4"	101	8	1,61
MSB200-1/16	1/16"	102	4	6,5	1/4"	203	8	1,61
MSB100-1/8	1/8"	51	5	8,5	5/16"	101	8	1,61
MSB200-1/8	1/8"	102	5	8,5	5/16"	203	8	1,61
MSB125-1/4	1/4"	51	7	11,5	7/16"	127	10	2,43
MSB250-1/4	1/4"	102	7	11,5	7/16"	254	10	2,43
MSB150-3/8	3/8"	51	8	15	9/16"	152	10	2,43
MSB300-3/8	3/8"	102	8	15	9/16"	305	10	2,43
MSB200-1/2	1/2"	76	10	18,5	11/16"	203	10	2,43
MSB400-1/2	1/2"	127	10	18,5	11/16"	406	10	2,43
MSB300-3/4	3/4"	102	12	23,5	15/16"	305	12	3,21
MSB500-3/4	3/4"	153	12	23,5	15/16"	508	12	3,21

**Description**  
Material: MS58 Brass

# FITTINGS

## HOSE CONNECTOR WITH PARALLEL THREAD

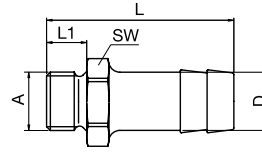

Part No.	A	D	L	L1	SW	
M10M8	M8x0,75	10	33,5	7	11	25
M10M10	M10x1	10	33,5	7	11	25
M10R1/8	1/8" BSP	10	33	7	14	25
M10R1/4	1/4" BSP	10	35	9	17	25
M13M12	M12x1,5	13	40	9	15	25
M13R1/4	1/4" BSP	13	42	9	17	25
M13M14	M14x1,5	13	43	10	17	10
M13M16	M16x1,5	13	40	9	17	10
M13R3/8	3/8" BSP	13	42	9	19	25
M19M24	M24x1,5	19	56	16	27	10
M19R1/2	1/2" BSP	19	54	12	24	10
M19R3/4	3/4" BSP	19	60	16	32	10

## HOSE CONNECTOR WITH TAPER THREAD BSPT

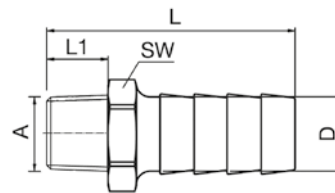
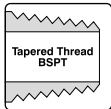

Part No.	A - BSPT	D (Inch)	D (mm)	L	SW	
MH02/04	1/8"	1/4"	6	34	10	25
MH02/06	1/8"	3/8"	10	34	12	25
MH04/04	1/4"	1/4"	6	37	14	25
MH04/06	1/4"	3/8"	10	37	14	25
MH04/08	1/4"	1/2"	13	37	14	25
MH06/06	3/8"	3/8"	10	37	17	25
MH06/08	3/8"	1/2"	13	37	17	25
MH06/10	3/8"	5/8"	16	40	17	25
MH06/12	3/8"	3/4"	19	44	21	25
MH08/06	1/2"	3/8"	10	40,5	21	25
MH08/08	1/2"	1/2"	13	40,5	21	25
MH08/12	1/2"	3/4"	19	46,5	21	25
MH08/16	1/2"	1"	25	50	27	25
MH12/06	3/4"	3/8"	10	42	27	10
MH12/08	3/4"	1/2"	13	42	27	10
MH12/12	3/4"	3/4"	19	48	27	10
MH12/16	3/4"	1"	25	50,5	27	10
MH16/08	1"	1/2"	13	45,5	34	10
MH16/12	1"	3/4"	19	54	34	10
MH16/16	1"	1"	25	54	34	10
MH24/20	1-1/2"	1-1/4"	32	58	48	10
MH24/24	1-1/2"	1-1/2"	38	58	48	10

See explanation of symbols on page 8



**PUSH LOCK - HOSE CONNECTOR PARALLEL THREAD**

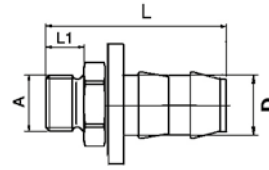

Part No.	A	D	L	L1	
P10R1/8	R1/8	10	39	7	10
P10R1/4	R1/4	10	39	7	10
P10M14	M14x1,5	10	42	7	10
P10R3/8	R3/8	10	43	7	10
P13R1/4	R1/4	13	39	10	10
P13R3/8	R3/8	13	43	10	10
P13R1/2	R1/2	13	43	10	10

**FEMALE HOSE CONNECTOR**

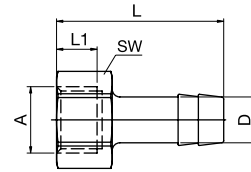

Part No.	A	D	L	L1	SW	
F10R1/8	1/8" BSP	10	33	8	14	25
F10R1/4	1/4" BSP	10	33	8	17	25
F10M14	M14x1,5	10	32	10	17	10
F13R1/4	1/4" BSP	13	39	8	17	25
F13M16	M16x1,5	13	40	10,5	22	10
F13R3/8	3/8" BSP	13	40	8	19	25

## FITTINGS

### HOSE CONNECTOR - BSPP THREAD, SWIVEL NUT AND 60° CONE SEAT

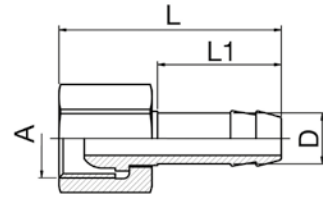

Part No.	A	D	L	L1	SW	
CM14	M14x1,5	10	39,5	22	17	10
CR1/4	G 1/4	10	39,5	22	17	10
CM16	M16x1,5	13	39	25	22	10
CR3/8	G 3/8	13	39	25	22	10
CR1/2	G 1/2	13	45	25	24	10
CM24	M24x1,5	19	52	32	30	10
CR3/4	G 3/4	19	52	32	32	10
CR1	G 1"	25	55	32	38	5

### HOSE CONNECTOR - BSPP THREAD, SWIVEL NUT AND FLAT SEAT

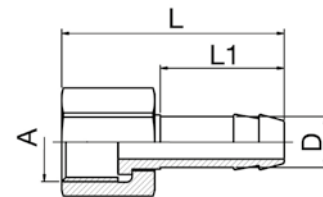

Part No.	A	D	L	L1	SW	
CFR3/8-10	G 3/8	10	39	25	22	10
CFR3/8-13	G 3/8	13	39	25	22	10
CFR1/2-13	G 1/2	13	39	25	24	10
CFR3/4-19	G 3/4	19	52	32	32	5
CFR1-25	G 1	25	55	32	38	5
CFR1.1/4-32	G 1-1/4	32	55	32	48	1
CFR1.1/2-38	G 1-1/2	38	55	32	52	1

**Description**  
Supplied without gaskets

### FIBER GASKETS FOR FLAT SEAT HOSE CONNECTOR

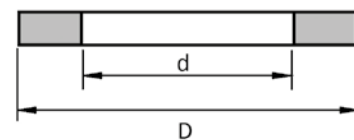

Part No.	D	d	Fit Thread Size	
GK38	14,5	8	G 3/8	1
GK12	18	12,5	G 1/2	1
GK34	24	16	G 3/4	1
GK1	30	25	G 1	1
GK114	38	31	G 1.1/4	1
GK112	44	36	G 1.1/2	1

**EXTENDED HOSE CONNECTOR**

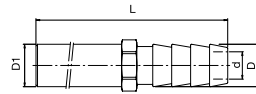

Part No.	D	D1	d	L	SW	
C120/10	10	10	6	120	11	10
C240/10	10	10	8	240	11	10
C150/13	13	14	9	150	15	10
C300/13	13	14	9	300	15	10

**90° HOSE CONNECTOR**

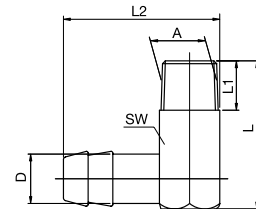

Part No.	A	D	L	L1	L2	SW	
V10M8	M8x0,75	10	27	9	33,5	11	25
V10M10	M10x1	10	27	9	28,5	11	25
V10R1/8	1/8" BSP	10	27	9	28,5	11	25
V10R1/4	1/4" BSP	10	34	11	40	15	25
V13R1/4	1/4" BSP	13	34	11	40	15	25
V13M14	M14x1,5	13	34	11	40	15	10
V13R3/8	3/8" BSP	13	35	12	42	17	25
V19M24	M24x1,5	19	47	16	58,5	24	10
V19R1/2	1/2" BSP	19	47	16	58,5	24	10

**Description**  
Nickle plated

**DOUBLE NIPPLE WITH TAPER THREAD**

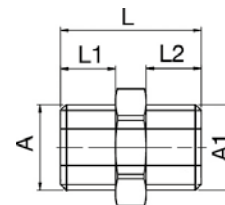
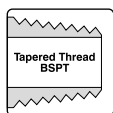

Part No.	A	A1	L	SW	
EC02/02	1/8"	1/8"	23	10	10
EC04/04	1/4"	1/4"	29	14	10
EC06/06	3/8"	3/8"	29	17	10
EC08/08	1/2"	1/2"	35	21	10
EC12/12	3/4"	3/4"	37	27	10
EC16/16	1"	1"	43	34	10
EC20/20	1.1/4"	1.1/4"	46	42	10

# FITTINGS

## DOUBLE NIPPLE WITH PARALLEL THREAD

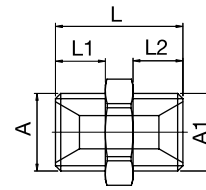

Part No.	A	A1	L	L1	L2	SW	
ZR1/8	G 1/8	G 1/8	21	8	8	17	10
ZM14	M14x1,5	M14x1,5	23	9	9	17	10
ZM14-R1/4	M14x1,5	G 1/4	23	9	9	17	10
ZR1/4	G 1/4	G 1/4	23	9	9	17	10
ZR1/4-R3/8	G 1/4	G 3/8	23	9	9	19	10
ZM16	M16x1,5	M16x1,5	23	9	9	19	10
ZM16-R3/8	M16x1,5	G 3/8	23	9	9	19	10
ZR3/8	G 3/8	G 3/8	23	9	9	19	10
ZR3/8-R1/2	G 3/8	G 1/2	29	9	12	24	10
ZR1/2-M14	G 1/2	M14x1,5	27	12	9	22	10
ZR1/2-M16	G 1/2	M16x1,5	27	12	9	22	10
ZR1/2	G 1/2	G 1/2	30	12	12	24	10
ZR1/2-R3/4	G 1/2	G 3/4	36	12	16	32	10
ZR1/2-R1/1	G 1/2	G 1	40	12	16	36	10
ZM24-R1/2	M24x1,5	G 1/2	36	16	12	27	10
ZR3/4	G 3/4	G 3/4	40	16	16	32	10
ZR3/4-M24	G 3/4	M24x1,5	40	16	16	32	10
ZR3/4-R1/1	G 3/4	G 1	40	16	16	36	10
ZR1/1-R1/1	G 1	G 1	42	16	16	36	10

## REDUCER NIPPLE

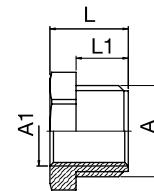

Part No.	A	A1	L	L1	SW	
GR1/4-R1/8	G 1/4"	G 1/8"	11	7	17	10
GM14-M10	M14x1,5	M10x1	11	7	17	10
GR3/8-R1/4	G 3/8"	G 1/4"	13	9	19	10
GM18-M14	M18x1,5	M14x1,5	14	9	22	10
GR1/2-R3/8	G 1/2"	G 3/8"	18	12	24	10
GR3/4-R1/2	G 3/4"	G 1/2"	24	16	27	10
GM24-M16	M24x1,5	M16x1,5	24	16	27	10
GR1/1-R3/4*	G 1"	G 3/4"	28	19	34	1
GR11/2-R3/4*	G 1-1/2"	G 3/4"	32	22	50	1
GR11/2-R1/1*	G 1-1/2"	G 1"	32	22	50	1

\* without sealant coating

**CONVERTER NIPPLE**

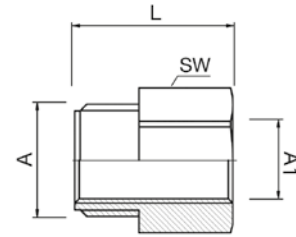

Part No.	A	A1	L	SW	
CN1/8-1/8	G 1/8	G 1/8	23	14	10
CN1/8-1/4	G 1/8	G 1/4	28	17	10
CN1/4-1/8	G 1/4	G 1/8	28	17	10
CN1/4-1/4	G 1/4	G 1/4	28	17	10
CN1/4-3/8	G 1/4	G 3/8	29	19	10
CN3/8-1/4	G 3/8	G 1/4	29	19	10
CN3/8-3/8	G 3/8	G 3/8	29	19	10
CN3/8-1/2	G 3/8	G 1/2	25	24	10
CN1/2-3/8	G 1/2	G 3/8	24	22	10
CN1/2-1/2	G 1/2	G 1/2	27	24	10
CN1/2-3/4	G 1/2	G 3/4	31	30	10

**FEMALE CONNECTION NIPPLE**

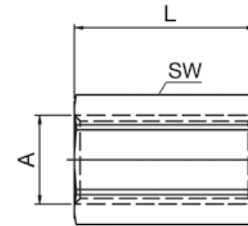

Part No.	A	L	SW	
FN1/8	G 1/8	22	11	10
FN1/4	G 1/4	26	17	10
FN3/8	G 3/8	26	22	10
FN1/2	G 1/2	30	27	10
FN3/4	G 3/4	36	32	10
FN1/1	G 1	40	41	10

# FITTINGS

## ADAPTOR NIPPLE BSPP - NPT



Part No.	BSPP	NPT	
BN1/8	1/8"	1/8"	10
BN1/4	1/4"	1/4"	10
BN3/8	3/8"	3/8"	10

**Description**

Material: Brass (Nickel Plated)

## ADAPTOR NIPPLE NPT - BSPP



Part No.	BSPP	NPT	
NB1/8	1/8"	1/8"	10
NB1/4	1/4"	1/4"	10
NB3/8	3/8"	3/8"	10
NB1/2	1/2"	1/2"	10

**Description**

Material: Brass (Nickel Plated)

**FEMALE REDUCTION NIPPLE**

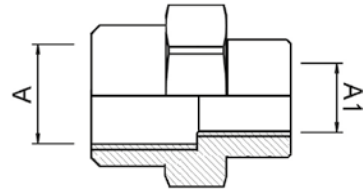

Part No.	A1	A	
FFN1/4-3/8	G1/4"	G3/8"	10
FFN1/4-1/2	G1/4"	G1/2"	10
FFN3/8-1/2	G3/8"	G1/2"	10
FFN1/2-3/4	G1/2"	G3/4"	5
FFN3/4-1	G3/4"	G1"	1

**Description**  
Material: Brass (Nickel Plated)

**T-CONNECTOR**

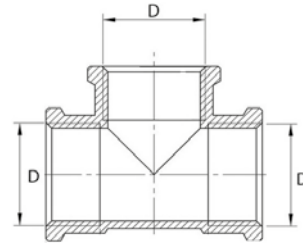

Part No.	D	
FT3/8	G3/8"	10
FT1/2	G1/2"	10
FT3/4	G3/4"	10
FT1	G1"	5
FT1-1/4	G1.1/4"	1
FT1-1/2	G1.1/2"	1

**Description**  
Material: Brass

**ROTATABLE CONNECTOR**

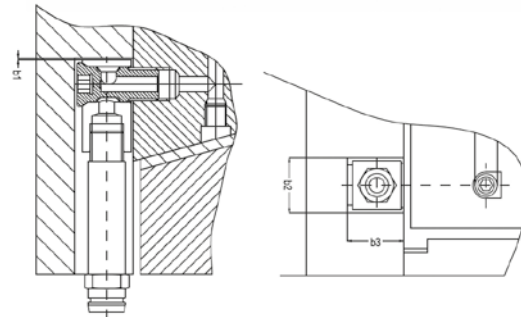

Part No.	Thread	b1	b2	b3	
VS-G1/8	G1/8"	1	16	17,0	10
VS-M10	M10	1	16	17,0	10
VS-G1/4	G1/4"	1	16	23,0	10
VS-M14	M14	1	16	23,0	10
VS-G1/2	G1/2"	1	16	35,5	10

**Description**  
Material: Brass (Nickel Plated)

# FITTINGS

## BARREL NIPPLE

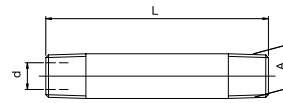

Part No.	T	L	d	
E50R1/8	1/8" BSPT	50	6	10
E100R1/8	1/8" BSPT	100	6	10
E150R1/8	1/8" BSPT	150	6	10
E200R1/8	1/8" BSPT	200	6	10
E50R1/4	1/4" BSPT	50	9	10
E100R1/4	1/4" BSPT	100	9	10
E150R1/4	1/4" BSPT	150	9	10
E200R1/4	1/4" BSPT	200	9	10
E100R3/8	3/8" BSPT	100	12	10
E150R3/8	3/8" BSPT	150	12	10
E200R3/8	3/8" BSPT	200	12	10

## EXTENSION NIPPLE

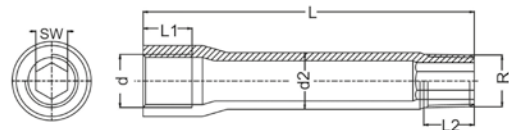
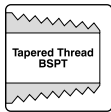



Part No.	d	R	d2	L	L1	L2	SW
EX18050	R1/8	R1/8	10	50	12	10	5
EX18075	R1/8	R1/8	10	75	12	10	5
EX18100	R1/8	R1/8	10	100	12	10	5
EX18125	R1/8	R1/8	10	125	12	10	5
EX14050	R1/4	R1/4	14	50	12	10	8
EX14075	R1/4	R1/4	14	75	12	10	8
EX14100	R1/4	R1/4	14	100	12	10	8
EX14125	R1/4	R1/4	14	125	12	10	8
EX14150	R1/4	R1/4	14	150	12	10	8

**Description**  
Material: Zinc Plated Steel



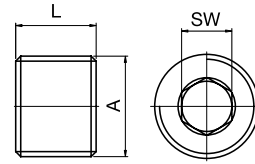

**PRESSURE PLUG TAPER**

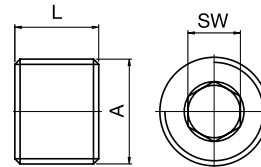

Part No.	A	L	SW	
RM8	M8x0,75	8	4	100
RM10	M10x1	8	5	100
R1/8	1/8" BSPT	8	5	100
RM12	M12x1,5	8	6	100
R1/4	1/4" BSPT	10	7	100
RM14	M14x1,5	10	7	100
R3/8	3/8" BSPT	10	8	100
R1/2	1/2" BSPT	10	10	100

**PRESSURE PLUG PARALLEL**



Part No.	A	L	SW	
RM8C	M8x0,75	8	4	100
RM10C	M10x1	8	5	100
R1/8C	1/8" BSP	8	5	100
RM12C	M12x1,5	8	6	100
R1/4C	1/4" BSP	10	7	100
RM14C	M14x1,5	10	7	100
R3/8C	3/8" BSP	10	8	100
R1/2C	1/2" BSP	10	10	100

**HEX PLUG PARALLEL**

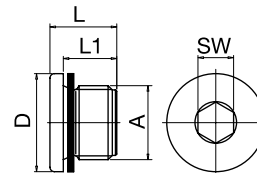

Part No.	A	D	L	L1	SW	
DM10	M10x1	14	11	8	5	25
DR1/8	G 1/8	14	11	8	5	25
DM12	M12x1,5	17	15	12	6	25
DR1/4	G 1/4	18	15	12	6	25
DM14	M14x1,5	19	15	12	6	25
DR3/8	G 3/8	22	15	12	8	25
DR1/2	G 1/2	26	18	14	10	25
DR3/4	G3/4"	32	21	16	12	1
DR1	G1"	40	22,5	16	17	1
DR1-1/2*	G1-1/2"	55	22,5	16	24	1

Description  
\*With O-ring

# FITTINGS

## CHANNEL PLUG

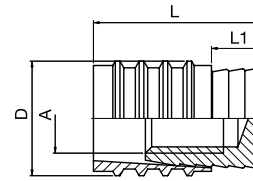

Part No.	A	D	L	L1	
S6	M3	6	11,5	3,5	25
S8	M4	8	11,5	3,5	25
S10-1	M6	10	14	4	25
S12	M6	12	14	4	25
S16	M8	16	16	4	25

## CHANNEL PLUG

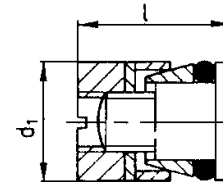



Part No.	d1	Length	
KN105-6	6	10	10
KN105-8	8	11	10
KN105-10	10	11	10
KN105-12	12	11	10
KN105-14	14	13	10
KN105-16	16	13	10

**Description**

Material: Brass  
 O-ring: FKM

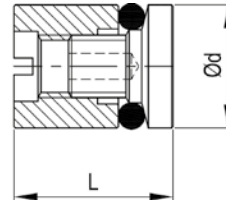
**CHANNEL PRESSURE PLUG, THREADLESS**



Part No.	L	d	Channel Bore d H13	Installation Key	
CP6	15	6	6	CPT6-..	10
CP8	15	8	8	CPT8-..	10
CP10	15	10	10	CPT10-..	10
CP12	15	12	12	CPT12-..	10

**Description**

Material: Brass  
O-ring: FKM

**INSTALLATION TOOL, WITH PLUG EXTRACTOR**



Part No.	Length	Plug diameter	
CPT6-150	150	6	1
CPT6-300	300	6	1
CPT8-150	150	8	1
CPT8-300	300	8	1
CPT10-150	150	10	1
CPT10-300	300	10	1
CPT12-150	150	12	1
CPT12-300	300	12	1

# VALVES

## SPRING SAFETY CHECK VALVE 0,8 BAR

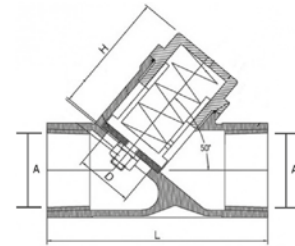

Part No.	A	D	H	L
SV-08-1/2	1/2"	12,5	31	65,5
SV-08-3/4	3/4"	18	40	75,5

**Description**

Material: Stainless steel

Spring relief pressure: 0,8 Bar

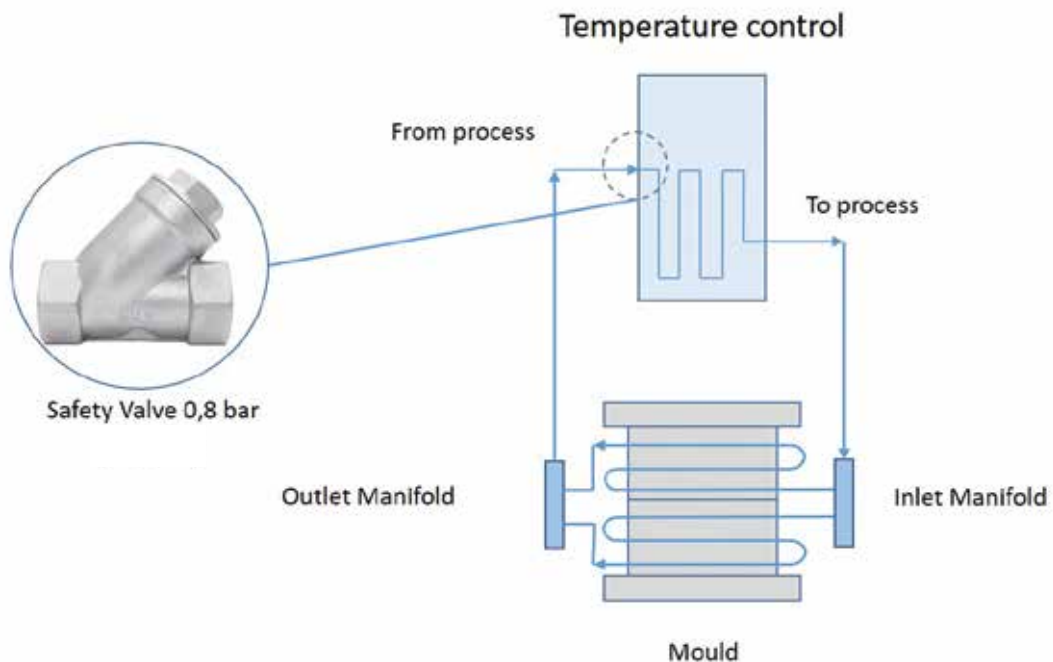

**Instructions for non-pressurized cooling systems:**

Safe-lock is activated by pressure of min. 0,8bar - therefore you must ensure that your cooling circuit is pressurized at all time.

Low temperature (0-90°C) temperature controls typically operates with open tank (no pressure) and the pump cannot ensure pressure throughout the entire system.

To pressurize these systems, it's required to install a safety valve on the return inlet on the temperature control unit - this will ensure enough back pressure to activate the Safe-Lock safety couplings. See the illustration for details:

**MINI BALL VALVE - MALE / FEMALE**

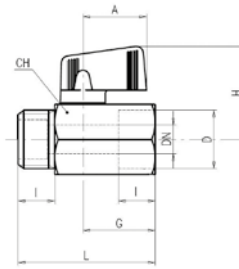
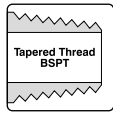

Part No.	Part No.	D	DN	I	L	G	A	H	CH
VMMF02R	VMMF02B	1/8"	5	10	41,5	22	22,5	31	21
VMMF04R	VMMF04B	1/4"	8	11	41,5	22	22,5	31	21
VMMF06R	VMMF06B	3/8"	8	11	41,5	22	22,5	31	21
VMMF08R	VMMF08B	1/2"	10	13	49	22	22,5	31	25

**MINI BALL VALVE - FEMALE/FEMALE**

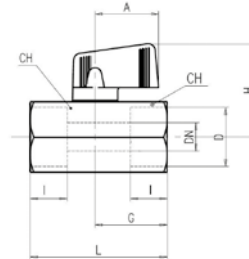
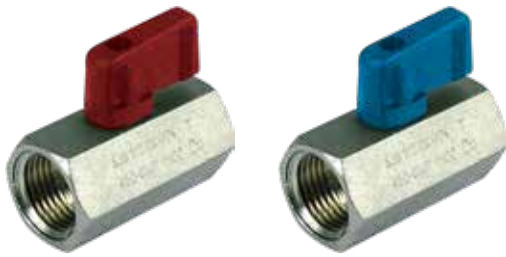

Part No.	Part No.	D	DN	I	L	G	A	H	CH
VM02R	VM02B	1/8"	6	10	41,5	22	22,5	31	21
VM04R	VM04B	1/4"	8	11	41,5	22	22,5	31	21
VM06R	VM06B	3/8"	8	11	41,5	22	22,5	31	21
VM08R	VM08B	1/2"	10	13	49	26	22,5	31	25

**Description**

**Quality:**

- Dual sealing system allows valve to be operated in either direction making installation easier
- No metal-to-metal moving parts
- No maintenance ever required
- Handle clearly shows ball position
- Silicone-free lubricant on all seals
- Chrome plated brass ball for longer life
- Each valve is seal tested for maximum safety

**Body:**

- One piece drawn sand blasted brass body with an extreme compact design
- Finest brass according to EN 12164 specification
- Patent n. 7011-B/89

**Thread:**

- ISO 7/1, BS21 Male thread: BSPT – Female thread: BSPP

**Stem:**

- Blowout-proof brass stem with FPM O-ring

**Handle:**

- Metal Handle removable with valve in service

**Seals:**

- Pure PTFE self-lubricating seats with flexible-lip design

**Working Pressure:**

- 30 Bar (450 PSI)

**Operating Temperature:**

- +90°C (+194°F)

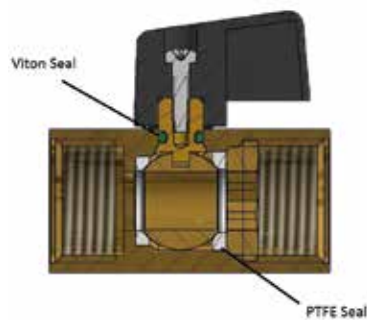

# VALVES

## BALL VALVE T-HANDLE - MALE / FEMALE

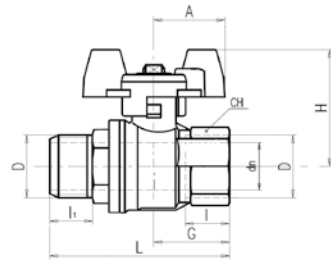

Part No.	Part No.	D	DN	I	H1	L	G	A	H	CH
VTMF04R	VTMF04B	1/4"	8	12	13,5	56,5	22,5	25	39	20
VTMF06R	VTMF06B	3/8"	9,5	12	13,5	56,5	22,5	25	39	20
VTMF08R	VTMF08B	1/2"	15	15,5	16,5	70	29,5	25	43	25
VTMF12R	VTMF12B	3/4"	19	17	18	76,5	32	30	49	31
VTMF16R	VTMF16B	1"	24	21	22	92,5	40,5	30	53	40
VTMF20R	VTMF20B	1-1/4"	30	23	24	106	46,5	57	84,5	49
VTMF24R	VTMF24B	1-1/2"	38	23	24	113	51	57	90,5	54

**Description**

**Quality:**

- 24h 100% seal test guaranteed
- Dual sealing system allows valve to be operated in either direction making installation easier
- No maintenance ever required
- Chrome plated brass ball for longer life
- Travel stops on body to avoid stresses at stem

**Body:**

- Hot forged sand blasted, nickel plated brass body and cap sealed with Loctite or equivalent thread sealant
- Finest brass according to EN 12165 and EN 12164 (formerly DIN 17660 and UNI 5705-65) specifications

**Flow:**

- Full port to DIN 3357 for maximum flow

**Thread:**

- EN 10226-1, ISO 228 Male thread: BSPT – Female thread: BSPP

**Stem:**

- Two FPM O-rings at the stem for maximum safety

**Seals:**

- Pure PTFE self-lubricating seats with flexible-lip design

**Working Pressure:**

- 40 Bar (600 PSI)
- Non-shock cold working pressure

**Operating Temperature:**

- +170°C (+350°F)

## BALL VALVE T-HANDLE - FEMALE / FEMALE

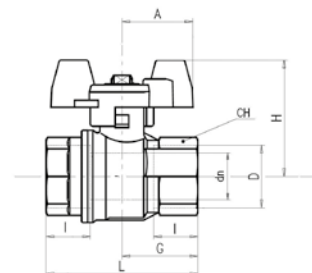

Part No.	Part No.	D	DN	I	L	G	A	H	CH
VT04R	VT04B	1/4"	8	12	45	22,5	25	39	20
VT06R	VT06B	3/8"	9,5	12	45	22,5	25	39	20
VT08R	VT08B	1/2"	15	15,5	59	29,5	25	43	20
VT12R	VT12B	3/4"	19	17	64	32	30	49	31
VT16R	VT16B	1"	24	21	81	40,5	30	53	40
VT20R	VT20B	1-1/4"	30	23	93	46,5	57	84,5	49
VT24R	VT24B	1-1/2"	38	23	102	51	57	90,5	54

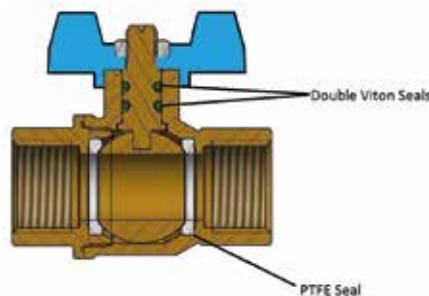

**BALL VALVE STANDARD HANDLE - MALE / FEMALE**

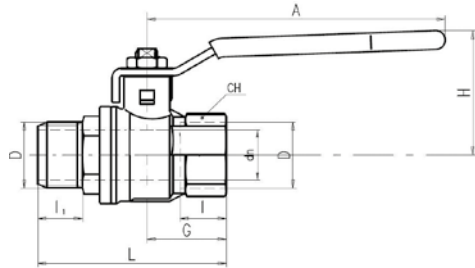
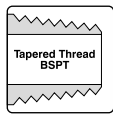

Part No.	Part No.	D	DN	I	I1	L	G	A	H	CH
VLMF04R	VLMF04B	1/4"	8	12	13,5	56,5	22,5	82	38	20
VLMF06R	VLMF06B	3/8"	9,5	12	13,5	56,5	22,5	82	38	20
VLMF08R	VLMF08B	1/2"	15	15,5	16,5	70	29,5	100	43	25
VLMF12R	VLMF12B	3/4"	19	17	18	76,5	32	120	50	31
VLMF16R	VLMF16B	1"	24	21	22	92,5	40,5	120	54	40
VLMF20R	VLMF20B	1-1/4"	30	23	24	106	46,5	158	73	49
VLMF24R	VLMF24B	1-1/2"	38	23	24	113	51	158	79	54

**BALL VALVE STANDARD HANDLE - FEMALE / FEMALE**

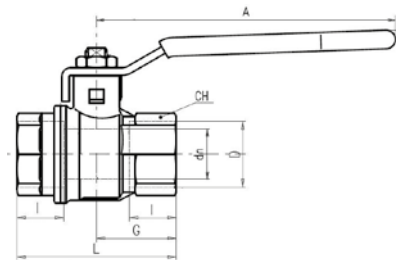

Part No.	Part No.	D	DN	I	L	G	A	H	CH
VL04R	VL04B	1/4"	8	12	45	22,5	82	38	20
VL06R	VL06B	3/8"	9,5	12	45	22,5	82	38	20
VL08R	VL08B	1/2"	15	15,5	59	29,5	100	43	25
VL12R	VL12B	3/4"	19	17	64	32	120	50	31
VL16R	VL16B	1"	24	21	81	40,5	120	54	40
VL20R	VL20B	1-1/4"	30	23	93	46,5	158	73	49
VL24R	VL24B	1-1/2"	38	23	102	51	158	79	54

**Description**

**Quality:**

- 24h 100% seal test guaranteed
- Dual sealing system allows valve to be operated in either direction making installation easier
- No maintenance ever required
- Chrome plated brass ball for longer life
- Travel stops on body to avoid stresses at stem

**Body:**

- Hot forged sand blasted, nickel plated brass body and cap sealed with Loctite or equivalent thread sealant
- Finest brass according to EN 12165 and EN 12164 (formerly DIN 17660 and UNI 5705-65) specifications

**Flow:**

- Full port to DIN 3357 for maximum flow

**Thread:**

- EN 10226-1, ISO 228 Male thread: BSPT – Female thread: BSPP

**Stem:**

- Two FPM O-rings at the stem for maximum safety

**Seals:**

- Pure PTFE self-lubricating seats with flexible-lip design

**Working Pressure:**

- 40 Bar (600 PSI)
- Non-shock cold working pressure

**Operating Temperature:**

- +170°C (+350°F)

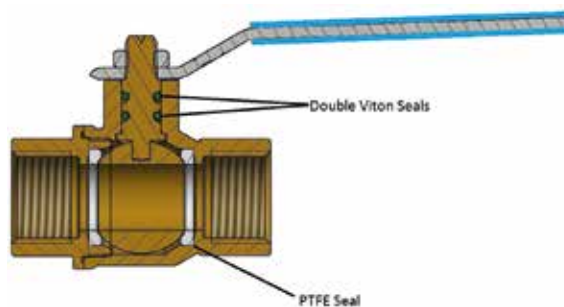

# VALVES

## 3 WAY BALL VALVE - FEMALE

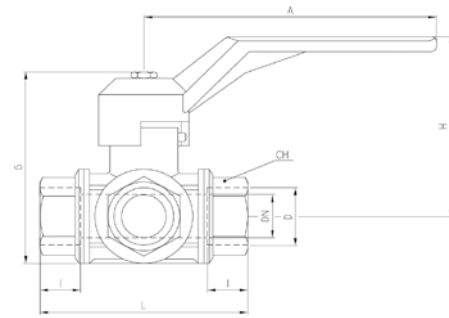

Part No.	D	DN	I	L	G	A	H	CH
V3F04R	1/4"	10	19	77	75	125	65	22
V3F06R	3/8"	12	19	77	75	125	65	22
V3F08R	1/2"	14	19	77	75	125	65	27
V3F12R	3/4"	18	23	92	91	145	83	34
V3F16R	1"	23	25	104	105	170	96	41
V3F20R	1.1/4"	29	27	118	115	170	102	50
V3F24R	1.1/2"	36	31	138	128	170	109	57

### Description

#### Quality:

- Chrome plated brass ball for longer life
- UNI 8858 cycle and torque test performed

#### Body:

- Hot forged sand blasted nickel plated body and caps
- 3 Way Lever design allows complete range of flow handling applications
- Copper alloy brass according to EN 12165 and EN 12164 specifications

#### Stem:

- Two NBR O-Rings at the stem for maximum safety

#### Seals:

- Four seats design limits mixture among various fluids in the system
- PTFE seals

#### Threads:

- ISO 228 female threads

#### Flow:

- Full port for lowest pressure drops

#### Working pressure:

- 20 Bar

#### Working temperature:

- -10 °C to + 120 °C



**STRAIGHT MALE**



Part No.	Part No.	Tube ØD	Thread
MSM081/8R	MSM081/8B	8	1/8"
MSM081/4R	MSM081/4B	8	1/4"
MSM083/8R	MSM083/8B	8	3/8"
MSM101/4R	MSM101/4B	10	1/4"
MSM103/8R	MSM103/8B	10	3/8"
MSM123/8R	MSM123/8B	12	3/8"
MSM121/2R	MSM121/2B	12	1/2"

**Description**  
Material: Brass, Nickel Plated. Seal: EPDM

**90° SWIVEL MALE**



Part No.	Part No.	Tube ØD	Thread
MSW081/8R	MSW081/8B	8	1/8"
MSW081/4R	MSW081/4B	8	1/4"
MSW083/8R	MSW083/8B	8	3/8"
MSW101/4R	MSW101/4B	10	1/4"
MSW103/8R	MSW103/8B	10	3/8"
MSW123/8R	MSW123/8B	12	3/8"
MSW121/2R	MSW121/2B	12	1/2"

**Description**  
Material: Brass, Nickel Plated. Seal: EPDM

**STRAIGHT FEMALE**



Part No.	Part No.	Tube ØD	Thread
MSF081/8R	MSF081/8B	8	1/8"
MSF081/4R	MSF081/4B	8	1/4"
MSF083/8R	MSF083/8B	8	3/8"
MSF101/4R	MSF101/4B	10	1/4"
MSF103/8R	MSF103/8B	10	3/8"
MSF123/8R	MSF123/8B	12	3/8"
MSF121/2R	MSF121/2B	12	1/2"

**Description**  
Material: Brass, Nickel Plated. Seal: EPDM

## PUSH IN FITTINGS

### ETHER BASED POLYURETHANE TUBING FOR PUSH-IN FITTINGS - TEMPERATURE MAX 70°C / PEAK 100°C

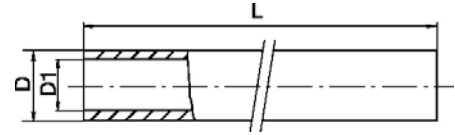
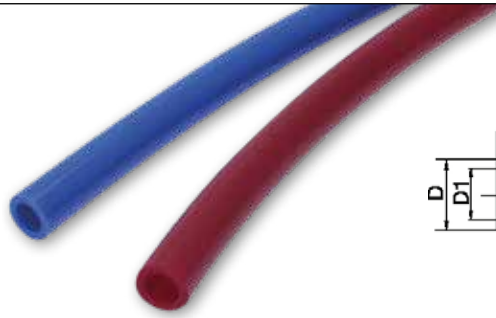

Part No.	Description	D (mm)	D1 (mm)	Working Pressure*		Bend Radius (mm)*	Coil Length L	Colour
				PSI	Bar			
PPU8B	Pneumatic Polyurethane Tubing 8mm x 5.5mm	8	5.5	116	8	31	30m	Blue
PPU8R	Pneumatic Polyurethane Tubing 8mm x 5.5mm	8	5.5	116	8	31	30m	Red
PPU10B	Pneumatic Polyurethane Tubing 10mm x 7mm	10	7	116	8	40	30m	Blue
PPU10R	Pneumatic Polyurethane Tubing 10mm x 7mm	10	7	116	8	40	30m	Red
PPU12B	Pneumatic Polyurethane Tubing 12mm x 8mm	12	8	116	8	43	30m	Blue
PPU12R	Pneumatic Polyurethane Tubing 12mm x 8mm	12	8	116	8	43	30m	Red

**Description**

\* Working pressure of 8 bar / 116 PSI is based on temperature of 20 °C, higher temperature will result in lower pressure resistance. See below graph for details

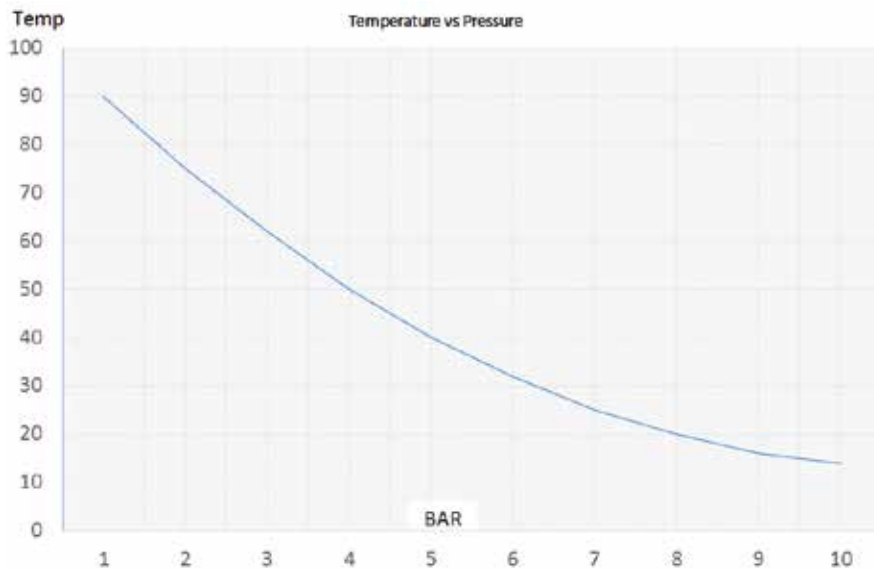

**3/4" INLINE ANODIZED MANIFOLD**

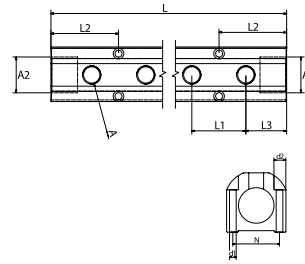

Part No.	Colour	Ports	A (BSPP)	A2 (BSPP)	L2	L3	L1	d1	d2	N	L
IM3-4-1/4-R	Blue	4	1/4"	3/4"	57,2	38,1	38,1	4,5	8	31	190,5
IM3-4-1/4-B	Red	4	1/4"	3/4"	57,2	38,1	38,1	4,5	8	31	190,5
IM3-6-1/4-R	Blue	6	1/4"	3/4"	57,2	38,1	38,1	4,5	8	31	266,7
IM3-6-1/4-B	Red	6	1/4"	3/4"	57,2	38,1	38,1	4,5	8	31	266,7
IM3-8-1/4-R	Blue	8	1/4"	3/4"	57,2	38,1	38,1	4,5	8	31	342,9
IM3-8-1/4-B	Red	8	1/4"	3/4"	57,2	38,1	38,1	4,5	8	31	342,9

**Description**

Rugged Low Cost Design  
 Anodized Aluminium in Blue or Red for easy identification of Flow and Return  
 Quick Mould Change  
 Eliminates Piping Errors  
 Shorter Hose Lengths minimise pressure drops and reduces clutter  
 Maximum Unrestricted Flow Rates Possible

**1" INLINE ANODIZED MANIFOLD**

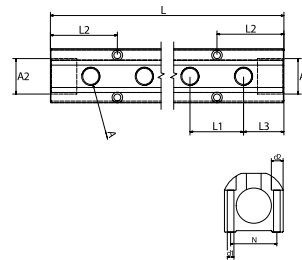

Part No.	Colour	Ports	A (BSPP)	A2 (BSPP)	L2	L3	L1	d1	d2	N	L
IM4-4-1/4-R	Blue	4	1/4"	1"	63,5	38,1	38,1	7	10,5	40,6	190,5
IM4-4-1/4-B	Red	4	1/4"	1"	63,5	38,1	38,1	7	10,5	40,6	190,5
IM4-4-3/8-R	Blue	4	3/8"	1"	63,5	38,1	38,1	7	10,5	40,6	228,6
IM4-4-3/8-B	Red	4	3/8"	1"	63,5	38,1	38,1	7	10,5	40,6	228,6
IM4-6-1/4-R	Blue	6	1/4"	1"	63,5	38,1	38,1	7	10,5	40,6	266,7
IM4-6-1/4-B	Red	6	1/4"	1"	63,5	38,1	38,1	7	10,5	40,6	266,7
IM4-6-3/8-R	Blue	6	3/8"	1"	63,5	38,1	38,1	7	10,5	40,6	330,2
IM4-6-3/8-B	Red	6	3/8"	1"	63,5	38,1	38,1	7	10,5	40,6	330,2
IM4-8-1/4-R	Blue	8	1/4"	1"	63,5	38,1	38,1	7	10,5	40,6	342,9
IM4-8-1/4-B	Red	8	1/4"	1"	63,5	38,1	38,1	7	10,5	40,6	342,9
IM4-8-3/8-R	Blue	8	3/8"	1"	63,5	38,1	38,1	7	10,5	40,6	431,8
IM4-8-3/8-B	Red	8	3/8"	1"	63,5	38,1	38,1	7	10,5	40,6	431,8
IM4-10-3/8-R	Blue	10	3/8"	1"	63,5	38,1	38,1	7	10,5	40,6	533,4
IM4-10-3/8-B	Red	10	3/8"	1"	63,5	38,1	38,1	7	10,5	40,6	533,4
IM4-12-3/8-R	Blue	12	3/8"	1"	63,5	38,1	38,1	7	10,5	40,6	635
IM4-12-3/8-B	Red	12	3/8"	1"	63,5	38,1	38,1	7	10,5	40,6	635

**Description**

Rugged Low Cost Design  
 Anodized Aluminium in Blue or Red for easy identification of Flow and Return  
 Quick Mould Change  
 Eliminates Piping Errors  
 Shorter Hose Lengths minimise pressure drops and reduces clutter  
 Maximum Unrestricted Flow Rates Possible

# MANIFOLDS

## 1-1/2" INLINE ANODIZED MANIFOLD

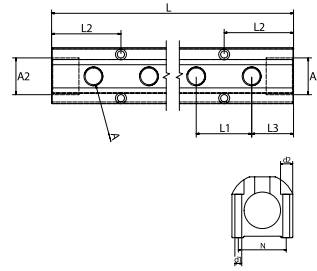

Part No.	Colour	Ports	A (BSPP)	A2 (BSPP)	L2	L3	L1	d1	d2	N	L
IM6-4-1/2-R	Red	4	1/2"	1-1/2"	76,2	50,8	50,8	7	10,5	57	254
IM6-4-1/2-B	Blue	4	1/2"	1-1/2"	76,2	50,8	50,8	7	10,5	57	254
IM6-6-1/2-R	Red	6	1/2"	1-1/2"	76,2	50,8	50,8	7	10,5	57	355,6
IM6-6-1/2-B	Blue	6	1/2"	1-1/2"	76,2	50,8	50,8	7	10,5	57	355,6
IM6-8-1/2-R	Red	8	1/2"	1-1/2"	76,2	50,8	50,8	7	10,5	57	457,2
IM6-8-1/2-B	Blue	8	1/2"	1-1/2"	76,2	50,8	50,8	7	10,5	57	457,2
IM6-10-1/2-R	Red	10	1/2"	1-1/2"	76,2	50,8	50,8	7	10,5	57	558,8
IM6-10-1/2-B	Blue	10	1/2"	1-1/2"	76,2	50,8	50,8	7	10,5	57	558,8
IM6-12-1/2-R	Red	12	1/2"	1-1/2"	76,2	50,8	50,8	7	10,5	57	660,4
IM6-12-1/2-B	Blue	12	1/2"	1-1/2"	76,2	50,8	50,8	7	10,5	57	660,4

### Description

Rugged Low Cost Design  
 Anodized Aluminium in Blue or Red for easy identification of Flow and Return  
 Quick Mould Change  
 Eliminates Piping Errors  
 Shorter Hose Lengths minimise pressure drops and reduces clutter  
 Maximum Unrestricted Flow Rates Possible

## BLANKING PLUGS

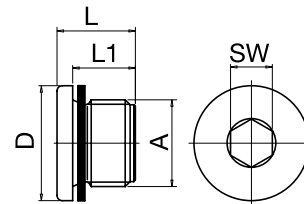

Part No.	A	D	L	L1	SW	VPE
DR3/4	G3/4"	32	21	16	12	1
DR1	G1"	40	22,5	16	17	1
DR1-1/2*	G1-1/2"	55	22,5	16	24	1

\* With O-Ring

**INLINE STAINLESS STEEL MANIFOLD**

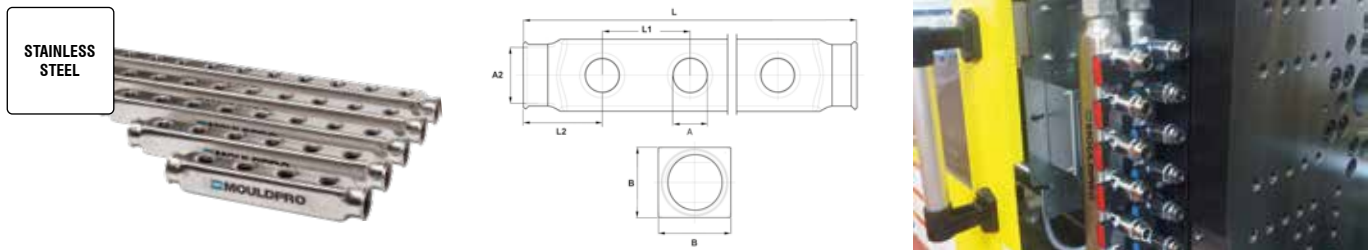

Part No.	Ports	A (BSPP)	A2 (BSPP)	L	L1	L2	B
SSIM4-4-1/2	4	1/2"	1"	240	50	45	40
SSIM4-6-1/2	6	1/2"	1"	340	50	45	40
SSIM4-8-1/2	8	1/2"	1"	440	50	45	40
SSIM4-10-1/2	10	1/2"	1"	540	50	45	40
SSIM4-12-1/2	12	1/2"	1"	640	50	45	40
SSIM5-4-1/2	4	1/2"	1-1/4"	240	50	45	50
SSIM5-6-1/2	6	1/2"	1-1/4"	340	50	45	50
SSIM5-8-1/2	8	1/2"	1-1/4"	440	50	45	50
SSIM5-10-1/2	10	1/2"	1-1/4"	540	50	45	50
SSIM5-12-1/2	12	1/2"	1-1/4"	640	50	45	50

**Description**  
 Stainless steel AISI 304  
 Perfect for aggressive water and oil.

**BRACKETS FOR STAINLESS STEEL MANIFOLDS**



Part No.	Type
SS-Bracket	1"
SS-5-Bracket	1-1/4"

**Description**  
 Electro plated steel bracket for installation of a single manifold.  
 2 Brackets needed for correct installation.

**EQUAL CONNECTOR FOR STAINLESS MANIFOLDS**

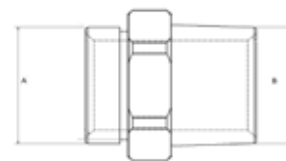

Part No.	Part No.	A	B
ECM1	1" BSPP	1" BSPT	1
ECM1-1/4	1-1/4" BSPP	1-1/4" BSPT	1

**Description**  
 Material: Brass Nickel Plated  
 O-Ring: EPDM

**BLANKING PLUG**



Part No.	Thread	Seal
SSEC1	1"	FKM
SSEC1-1/4	1-1/4"	Viton

## SEALANT AND TAPE

### PTFE TAPE



Part No.	Size	Length
TEF	12 mm	12 m

**Description**

Excellent for sealing all thread sizes  
 Temperature range: up to 230°C

### THREAD LOCKER



Part No.	Size	Max Thread	Temperature range
77	50 ml.	< M80	-50°C - +150°C

**Description**

Anaerobic Thread locker for permanent sealing of metal threaded fittings  
 Single component, liquid adhesive that cures hard in the absence of air or oxygen  
 Maximum Thread Size: M80  
 Disassembly strength: High  
 Temperature range: -50°C - +150°C  
 Breakaway torque: 32 Nm  
 Pack sizes: 50ml

**PIPE SEALANT**



Part No.	Size	Max Thread	Temperature range
542	50 ml.	< 3/4"	-50°C - +150°C

**Description**

Anaerobic thread sealant for fine metal threaded fittings, especially hydraulic pipes  
 Single component, liquid adhesive that cures hard in the absence of air or oxygen  
 Maximum pipe size: 3/4"  
 Disassembly strength: Medium  
 Temperature range: -50°C - +150°C  
 Breakaway torque: 15 Nm  
 Pack sizes: 50ml

**PIPE SEALANT**



Part No.	Size	Max Thread	Temperature range
577	50 ml.	< 3"	-50°C - +150°C
577-2	250 ml.	< 3"	-50°C - +150°C

**Description**

General purpose anaerobic thread sealant for all coarse metal threads  
 Single component, liquid adhesive that cures hard in the absence of air or oxygen  
 Maximum Pipe Size: 3"  
 Disassembly strength: Medium  
 Temperature range: -50°C - +150°C  
 Breakaway torque: 11 Nm  
 Pack sizes: 50ml, 250ml

# 02.

## FLOW MEASUREMENT AND CONTROL

**81**

02.1 FLOSENSE



**84**

02.2 FLOW MEASUREMENT



**87**

02.3 DE-SCALING



**89**

02.4 PRESSURE TESTING



**90**

02.5 MOULDHEATERS



**92**

02.6 FILTERS





**FLOSENSE MONITOR**



The new affordable, flexible Flosense monitor system is made for accurate measuring and monitoring flow, temperature and pressure variations in cooling circuits.

The system can be configured to fit any application:

- Single or Dual sensor input (Inlet/Outlet)
- Multi Sensor (Flow, Temperature and Pressure)
- Delta T monitor
- Delta P monitor
- Alarm Output
- Data storage and export function
- Touch Display
- Turbulent Flow Indicator

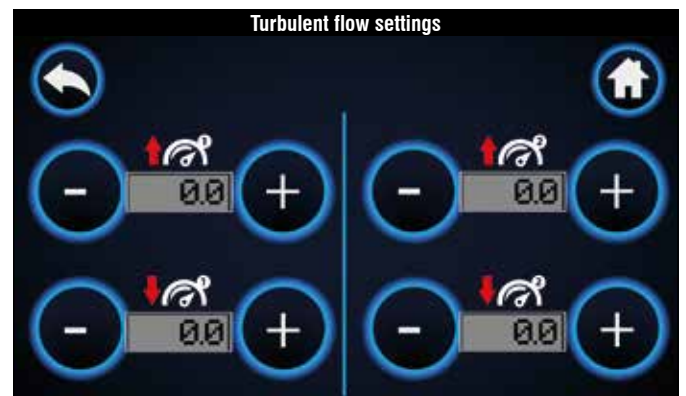

Flosense can be used for monitoring a single flow circuit

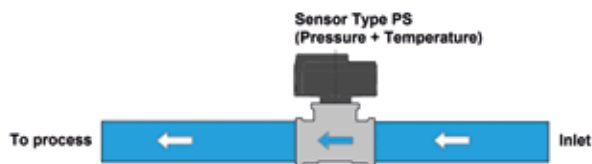

Reading and monitoring flow, temperature and pressure will give the operator a good overview of the process.

In Mould cooling processes you can benefit by having 2 sensors (Inlet+return) as the control will measure the differences in Temperature and Pressure also known as Delta T and Delta P. With these values you can monitor that the heat exchange is consistent and instability in pressure which indicates leakages, blocked waterways etc.

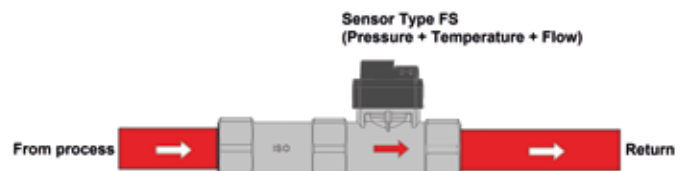

The system is designed to be installed in various applications:

- Mouldheater (Temperature controls)
- Critical cooling channels
- Main water supply
- Manifolds feeding multiple channels

Any variation in the values monitored will trigger an alarm which can be connected to supporting equipment.

## TOUCH CONTROL

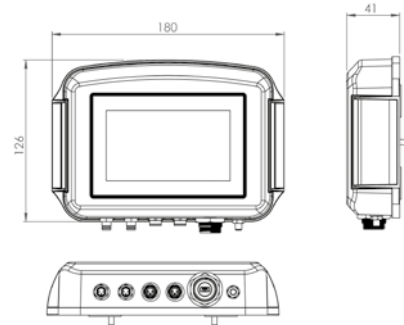

Part No.	Display Type	Sensor input	Alarm Output	Voltage
FS-T400	Touch	2	Yes	12 V.

### Description

Premium quality touch screen with easy and logic interface.  
Supplied with wall hang bracket for easy installation.  
Includes: Power Supply and USB Cable.

## MULTI SENSOR KIT TYPE FS - STAINLESS STEEL HOUSING - FOR RETURN PIPING

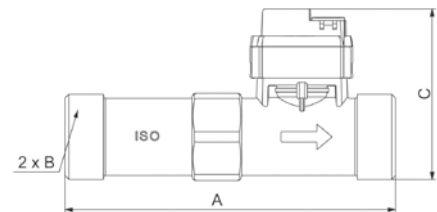

Part No.	Flow capacity l/m	A	B	C	Max Temperature
FS-115	1-15	110	G 3/4"	58,8	120°C
FS-240	2-40	110	G 3/4"	58,8	120°C
FS-5100	5-100	129	G 1"	66,5	120°C
FS-10200	10-200	137,5	G 1-1/4"	74,1	120°C

### Description

Includes Flow Pipe and Multi Sensor (cable not included)

## OPTIONAL (NOT INCLUDED IN THE KIT) AISI 316

### Swivel Reducer Nipple Female/Female



### Swivel Hosetail



Part No.	A1 x A2	Part No.	A1 x D1
RNF-316-1	3/4" x 3/8"	HT-316-2	3/4" x 19
RNF-316-2	3/4" x 1/2"	HT-316-3	1" x 25
RNF-316-3	1" x 3/4"	HT-316-4	1.1/4" x 32
RNF-316-4	1.1/4" x 1"		

**PRESSURE & TEMPERATURE SENSOR TYPE PS**



Part No.	Pressure Range Bar	Thread	Max Temp.
PS-100-G1/2	0-10	1/2" BSPP	120°C

**Includes**  
For Inlet Piping  
Cable not included

**T-CONNECTOR AISI 316**

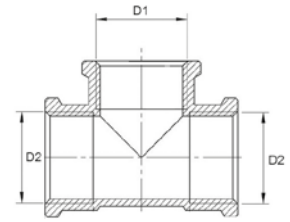

Part No.	D1	D2
T-316-1	1/2"	1/2"
T-316-2	1/2"	3/4"
T-316-3	1/2"	1"
T-316-4	1/2"	1.1/4"
T-316-5	1/2"	1.1/2"

**SENSOR CABLE**



Part No.	Connection	Length (mm)
FS-SC1200	M8/Molex	1200
FS-SC2900	M8/Molex	2900

**EXTENSION CABLE**



Part No.	Connection	Length (mm)
FS-EC1000	M8/M8	1000
FS-EC2000	M8/M8	2000
FS-EC5000	M8/M8	5000

**SPARE SENSORS: FLOW/PRESSURE/TEMPERATURE**



Part No.	Flow capacity l/m	Max Temperature
FS-S1-15	1-15	120°C
FS-S2-40	2-40	120°C
FS-S5100	5-100	120°C
FS-S10200	10-200	120°C

**SPARE PRESSURE -TEMP SENSORS**



Part No.	Pressure range Bar	Max Temperature
PS-P10	0-10	120°C

## FLOW MEASUREMENT

### VORTEX DIGITAL SINGLE ZONE MONITOR



Part No.	Flow capacity	Connection	Voltage
SZ-120	1-20 l/m	G 1/2	18..30DC
SZ-240	2-40 l/m	G 1/2	18..30DC
SZ-5100	5-100 l/m	G 3/4	18..30DC

**Description**

- Integrated temperature measurement
  - Flow measurement
  - Limit setting of flow and temperature
  - Alarm output signal
  - Rotatable display
  - Temperature range from -10°C to 90°C
- Material: Stainless steel body and connection  
 Pressure: 12 bar  
 Temperature: from -10 to +90 C°  
 Protection class: IP 65/IP67.

### WALL PLUG POWER SUPPLY



Part No.	Voltage input	Voltage output
SZ-P230	100-240V.	24 V.

**Description**

Kit including: Wall plug cable, power supply and M12 Connector cable

### POWER SUPPLY



Part No.	Voltage input	Connection	Voltage output
SZP-100	120..230 V.	DIN Rail	24DC

**POWER AND DATA CABLE M12**

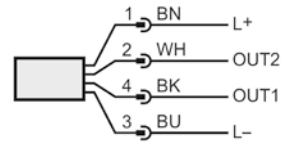

Part No.	Length	Connection	Voltage range
SZC-3000	3 m.	M12	24DC

**WATERFLOW REGULATOR**

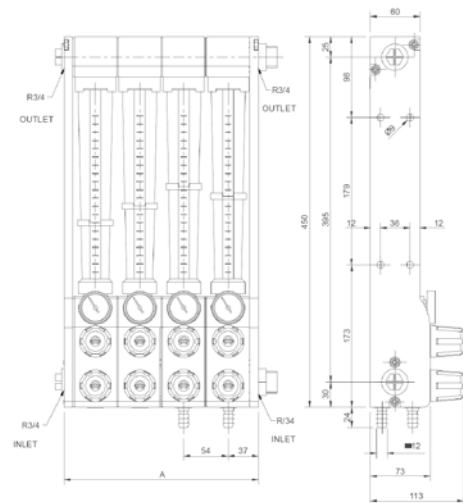

Part No.	Main Connections inlet / outlet	Max.Temp.	Zones	Zone Connection	Dimension A
MPR02R	R 3/4"	95°C	2	R 3/8"	126
MPR04R	R 3/4"	95°C	4	R 3/8"	231
MPR06R	R 3/4"	95°C	6	R 3/8"	339
MPR08R	R 3/4"	95°C	8	R 3/8"	444
MPR10R	R 3/4"	95°C	10	R 3/8"	552
MPR12R	R 3/4"	95°C	12	R 3/8"	659

**Description**

Water flow regulators are ideal for regulating the flow rate of water passing through them as well as the water outlet temperature. The high quality construction and design make the unit one of the most competitive.

**Technical characteristics**

- The tube is made of Polyamide (standard).
- Zone Flow Capacity 0-18 L/M
- Interior and exterior bodies are made of PA 6 with 30% fibre glass.
- Brass regulating taps.
- Thermometers (standard).
- Stainless steel interior tie-rods.
- Vitrilic rubber o-rings (hardness: 70 SHA).



# FLOW MEASUREMENT

## SPARE PART LIST

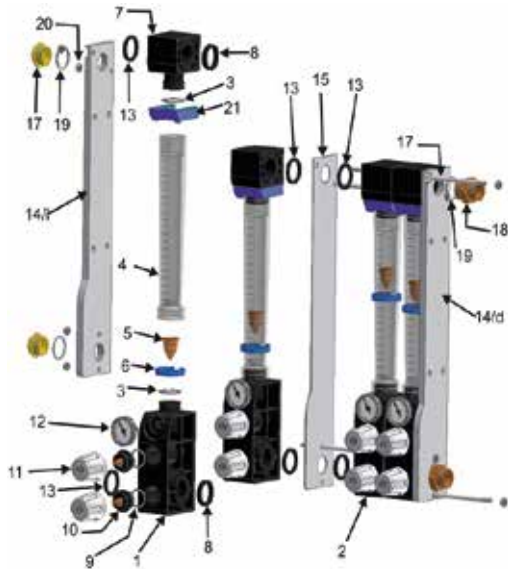

No	Part No.	Description
1	MPR-S-1	Inferior body 3/8 BSP connections
2	MPR-S-2	Inferior body with pipes
3	MPR-S-3	Tube O-ring
4	MPR-S-4	Polyamide tube
5	MPR-S-5	Brass
6	MPR-S-6	Level clip
7	MPR-S-7	Superior body
8	MPR-S-8	Intermediate o-ring
9	MPR-S-9	Tap O-ring 21x3
9.1	MPR-S-9.1	Tap O-ring Ø6x2
10	MPR-S-10	Tap
11	MPR-S-11	Knob
12	MPR-S-12	Thermometer
13	MPR-S-13	End O-ring / left 28x35x3,5
14 d	MPR-S-14d	Right aluminium end plate
14 i	MPR-S-14i	Left aluminium end plate
15	MPR-S-15	Intermediate plate
16	MPR-S-16	Fix rod
17	MPR-S-17	Plastic cap
18	MPR-S-18	3/4" brass connector (optional)
20	MPR-S-20	Nut
21	MPR-S-21	Tube security clip
22	MPR-S-22	End O-ring / right 28x35x5,5

## FLOW INDICATOR



Part No.	Flow Rate H <sub>2</sub> O LPM		Length	Ø mm	Thread	AF	Max Pressure (bar)
	Min	Max					
CFV1BN	1	10	59	25	1/4"	19	10
CFV2BN	2	20	71	30	3/8"	24	8
CFV3BN	3	30	71	30	1/2"	24	8
CFV4BN	4	40	106	47	3/4"	40	5
CFV5BN	6	60	106	47	1"	40	5

### Description

#### Use:

The CFV impeller flow indicators are generally used to monitor the correct flowing and circulation of a fluid into a pipeline. They are ideal for cooling and heating circuits, water treatment, and plastics processing equipment.

#### Note:

Flow rates refer to a vertical mounting with fluid inlet upwards.

#### Specifications:

Body	Nickel-plated brass
Impeller	Red Hostaform
Glass	Pirex
Seals	NBR
Max temperature	90°C

**DE-SCALING PUMP - WITH FLOW REVERSER**

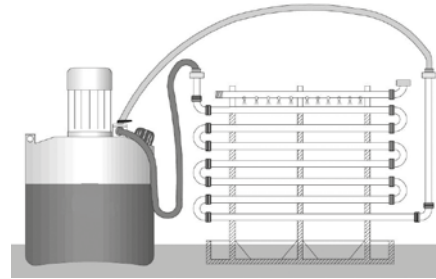

Part No.	Tank Capacity	Flow Rate	Reverse system	Fittings	HP
DP15M	15 l.	48 l/min.	Manual	1/2"	0,2
DP15A	15 l.	40 l/min	Automatic	1/2"	0,17
DP30M	24 l.	90 l/min.	Manual	1/2"	0,45
DP30A	24 l.	91 l/min.	Automatic	1/2"	0,45

**Description**

Used for clearing blocked or badly corroded heating and cooling circuits on Injection Moulding Machines and Moulds. Even when not blocked a relatively thin layer of scale or corrosion can act as an insulator and have a huge impact on the efficiency of your circuit. Simply fill up the pump with the descaling fluid, connect the pump to the inlet and outlet of the circuit and turn on the pump. Regular reversal of flow direction, either manual or automatic, speeds up operation and assists in dislodging any solid matter present in pipework and cooling circuits.

By using the pump together with the recommended range of descaling fluids to remove both rust and limescale deposits. The descaling fluid contains a colour change indicator to monitor performance; the translucent tank means that the user can see when the red colour runs clear and is no longer effective. Use the neutralising fluid to create a pH neutral fluid which can be easily disposed of.

**Easy, safe and professional maintenance of mould cooling circuits and temperature controllers**

- Compact and portable
- Safe and easy to use
- Flow reversing system
- Full range of cleaning products available
- 4 models available to suit your application

**Mould Cooling circuits which are corroded or partly blocked by scale cause:**

- Reduced flow
- Reduced efficiency
- Longer cycle times
- Temperature problems
- Increased maintenance
- Faulty parts



Automatic Reverser

Manual Reverser

Cooling pipe with Scale build-up

Fig. 1 Clockwise circulation

Fig. 2 Counterclockwise circulation

# DE-SCALING

## DE-SCALING SOLUTION



Part No.		kg	Weight	Copper	Steel	Stainless Steel	Aluminium	Brass	Tin	Light alloys	Galvanised Iron
<b>DESCALING CHEMICALS</b>											
RL10	Remover Liquid	10	10 kg	•	•			(•)			
RL10P	Remover Plus Liquid	10	10 kg	•	•			(•)			
RP10	Remover Plus Powder	10	10 kg			•	•	•	•	•	
<b>NEUTRALIZING CHEMICALS</b>											
NP10	Neutralizer	10	10 kg	•	•	•	•	•	•	•	•

**Description**

**Remover Liquid**

Concentrated descaling liquid with powerful reaction for systems and heat exchangers.

**Remover Plus Liquid**

Concentrated descaling liquid (non-fuming), with degreasing action, for systems and heat exchangers.

**Remover Plus Powder**

Concentrated descaling powder (non-corrosive, non-fuming) for systems and heat exchangers.

**Neutralizer**

Neutralizing powder to remove residual acidity after descaling systems and heat exchangers. Also suitable for neutralizing descaling chemicals after use, thus making it possible to drain them.



**PRESSURE TEST UNIT**



Part No.	Pressure (BAR)	Connection	Weight
MP-60	0-60	1/2 Female BSP	5,5 kg

**Description**

Pressure test unit - for easy leakage test of Mould circuits  
 Supplied with connecting hose and water tank

# MOULDHEATERS

## TEMPERATURE CONTROL UNITS WATER/OIL



Mouldpro Temperature controls are made to ensure reliable and accurate heating and cooling circuits

- 24 month warranty
- Speck Pumps (Germany)
- SMC Solenoid valves ( cooling and filling ) in brass
- Stainless Heaters / Tanks
- Insulated Water tanks
- Safety thermostat
- Soft wheels

Optional: Serial Interface 4-20mA, RS 485, 0-10 volt

Model		TCU-90	TCU-90L	TCU-90DC	TCU-120	TCU-150	TCU-200	TCU-200L	
Fluid		Water				Oil			
Maximum Temperature	°C	90	90	90	120	150	200	200	
Heating Power	Kw	9	18	9	9	9	9	18	
Cooling Capacity	Kw	40	40	Direct	Direct	80	20	40	
Tank Capacity	Lit.	12	35	-	-	-	20	35	
Pump Capacity	Max Flow (l/m)	60	60	70	70	40	60	60	
	Max Pressure (bar)	3,5	3,5	2,2	2,2	5	3,5	3,5	
	Power Kw	0,5	0,5	0,37	0,37	0,5	0,5	0,5	
Connections Process	→	3/4"	3/4"	1"	1"	3/4"	3/4"	3/4"	
	←	3/4"	3/4"	1"	1"	3/4"	3/4"	3/4"	
Connections Cooling	→	3/4"	3/4"	3/4"	3/4"	3/4"	3/4"	3/4"	
	←	1/2"	1/2"	3/4"	3/4"	3/4"	1/2"	1/2"	
Dimensions	mm (WxDxH)	295x575x495	365x750x785	325x610x750	325x610x750	325x610x750	330x610x690	365x750x785	
Weight	KG.	40	60	50	50	55	50	60	
Power Supply	V/Ph/Hz	400/3/50-60-PE							

Model		TCU-90	TCU-90L	TCU-90DC	TCU-120	TCU-150	TCU-200	TCU-200L
<b>Features</b>								
Acoustic Alarm		-	-	•	•	•	•	•
Mould drain/reverse pump direction		•	•	-	-	-	-	-
Liquid level sensor		•	•	•	•	•	•	•
Sensor failure monitor		•	•	•	•	•	•	•
Hose rupture/leakage monitor		•	•	•	•	•	•	•
Tank/Heaters made of SS		•	•	•	•	•	•	•
Security Thermostat		•	•	•	•	•	•	•
Automatic water filling		•	•	•	•	•	-	-
Castors		•	•	•	•	•	•	•
Solid State Relays		-	•	•	•	•	•	•
Magnetic Pump		-	-	-	-	•	-	-

**CORROSION, SCALE AND BIOLOGICAL INHIBITORS**



**Performance Properties**

Mouldpro Inhibitors have been specially formulated with Propylene or Ethylene Glycol for use as an Industrial Grade additive for use in Mould Cooling and Heating systems.



**CoolFlo IGE-25**  
Ethylene based



**CoolFlo NPT-25**  
Propylene based



**ThermaFlo DTX-25**  
Ethylene based

**Optimum Flow:** Improved heat transfer characteristics, including; lower Dynamic Viscosity and higher Thermal Conductivity.



**Protection:** Contains synergistic corrosion inhibitors to protect metals commonly found in mould cooling systems.



**Biodegradable:** Mixtures are readily biodegradable (90% over ten days) and will not remain in the environment or bio-accumulate.



**Scale Protection:** Contains scale and biological inhibitors to help prevent fouling - thus promoting long operational life and high thermal efficiency.



**Non Toxic:** Has a toxicity rating: "Relatively Harmless" as confirmed by the Hodge & Sterner Scale.



Part No.	Type	Temperature range	Container size
IGE-25	Ethylene	-50 to +90°C	25 Ltr
NPT-25	Propylene	-50 to +90°C	25 Ltr
DTX-25	Ethylene	-50 to +140°C	25 Ltr

**REFRACTOMETER**



Part No.	Scale	Ethylene Glycol	Propylene Glycol	Accuracy
RFM-200ATC	Brix	Yes	Yes	±0,1%

**Includes**

Ethylene Glycol: -60°C - 0°C / 0-66.6%  
 Propylene Glycol: -50°C - 0°C / 0-62.4%  
 Simple, accurate and repeatable measurement of concentration of glycol antifreeze with Automatic Temperature Compensation (ATC).  
 Includes calibration screwdriver, and case.

**DIGITAL PH METER**



Part No.	Measuring range	Resolution	Accuracy
PHM-100	0-14 pH	0,01 pH	±0,1pH

**Includes**

A great waterproof pH pen that will give you accurate pH measurements. There will be no need to use pH tricky test kits any more. It is very simple to use and the large LED display makes it easy to read. Kit includes 2 types buffer solution

# FILTERS

Inline filters specially designed for cooling channels or core cooling channels. The filter cartridge removes dirt particles, rust, or scale deposits. The temperature filter is made of stainless steel and brass. Easy maintenance of the filter:

1. Separate the 2 housing parts
2. Clean filter in an ultrasonic bath
3. Re-assemble the 2 housing parts

## INLINE FILTER

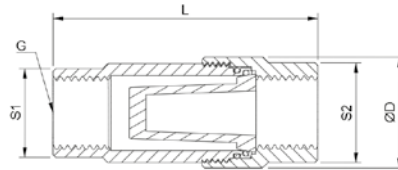

Part No.	Ø D	G	S1	S2	L	Filter area mm <sup>2</sup>
ILF-R1/4	20	1/4" BSP	16	18	48	660

**Description**  
Spare filter: SF-R1/4

## INLINE FILTER

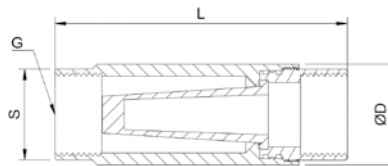

Part No.	Ø D	G	S	L	Filter area mm <sup>2</sup>
ILF-R3/4	32	3/4" BSP	29	93,5	2500

**Description**  
Spare filter: SF-R3/4

## INLINE FILTER - WITH MAINTENANCE INDICATOR

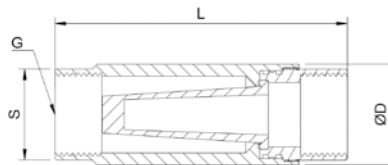

Part No.	Ø D	G	S	L	Filter area mm <sup>2</sup>
ILF-R3/4-M	32	3/4" BSP	29	93,5	2500

**Description**  
Spare filter: SF-R3/4  
Pressure loss: 10-15%  
Operating temperature: Max 140 degrees  
Max. Pressure: 8 bar  
Pore size (filter): 100 µm  
Material: Stainless steel  
Seals: FKM

Avoid problems in the cooling lines and extend the lifetime of your mould heater or chiller.

Contaminated fluid enters the inlet port where it is dispersed by the unique tapered radial flow channels. Fluid passes down the outside of the centrally mounted rare earth magnetic core which captures contamination particles along its length, resulting in excellent filtration efficiency.

The geometry of the magnetic flux circuit means that contamination builds up in a controlled way, ensuring that the filter can never block, irrespective of how much contamination is held. Channels remain open allowing fluid to continue to flow freely.

The filtered fluid flows through the return slots located in the upper section of the magnetic core, down through the centre and exits through the outlet port.

**Cleaning**

Using the supplied cleaning tool, a fully contaminated core can be cleaned in under 30 seconds. Only metallic particles are removed from the filter and these can be easily disposed. There are no dirty cartridges!

**Installation Location**

Place on the cooling supply or return. On temperature control or chiller.

**Benefits**

- Sub-micron filtration
- Large holding capacity
- High intensity rare earth magnetic material
- No pressure loss - even if full
- Suitable for all machining applications
- Environmentally responsible
- No consumables



Magnetic circuit & fluid flow path.

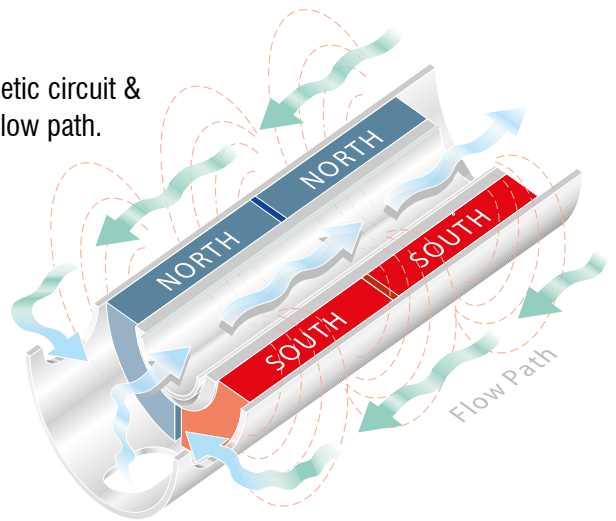

# FILTERS

## MAGNETIC FILTER

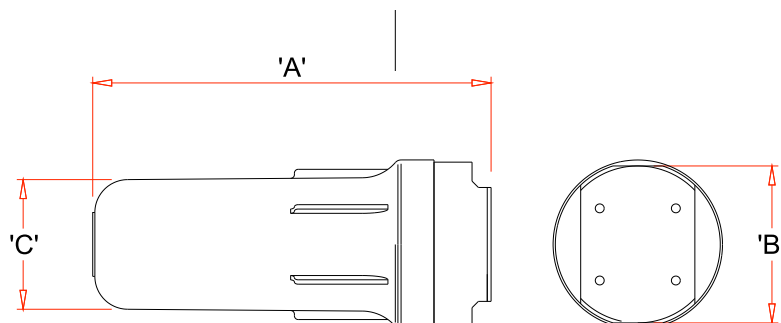

Part No.	A	B	C	Port size	Capacity (kg)	Max Flow Rate Ltrs/min	Temperature range	Material Housing	Material Tube	Max Pressure Bar
MP100	190	105	95	1" BSP	1	70	5-50°C	ALU, anodised	SAN (Plastic)	12
MP110	315	125	100	1" BSP	2	100	5-50°C	ALU, anodised	SAN (Plastic)	12
MP120	605	135	200	1-1/2" BSP	4	150	5-50°C	ALU, anodised	SAN (Plastic)	12

## MAGNETIC FILTER - HIGH TEMP

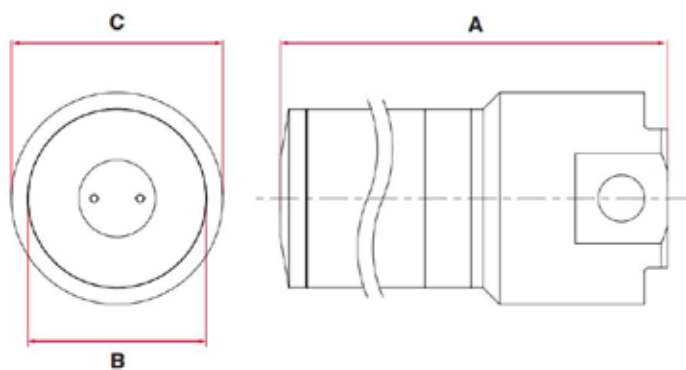

Part No.	A	B	C	Port size	Capacity (kg)	Max Flow Rate Ltrs/min	Temperature range	Material Housing	Material Tube	Max Pressure Bar
MP100SS	247	116	125	1" BSP	1	70	0-140°C	316 Stainless	316 Stainless	80
MP110SS	365	116	125	1" BSP	2	100	0-140°C	316 Stainless	316 Stainless	80
MP120SS	625	116	125	1-1/2" BSP	4	150	0-140°C	316 Stainless	316 Stainless	80

**STAINLESS STEEL IN-LINE FILTER - MPF-80-200**



Part No.  
MPF-80-200

MPF-80-200  
with maintenance  
indicator

Dirt particles in coolants often result in blockages in small cooling channels and can render mould inserts useless. This maintenance friendly Mouldpro stainless steel in-line filter MPF-80-200 offers superior low cost protection against foreign body particles, in particular for conformal cooling channel of injection moulding tools.

The filter can be flanged to the mould or operated in conjunction with temperature control units.

**Sure protection of your temperature cooling channels**

High filter performance is based on a starshaped folded stainless steel sieve that prevents the ingress of all particles of >200 µm into the cooling channel.

**Versatile use**

The filter is suitable for use with water- or oil-based coolants with a flow volume of up to 80 l/ min and offers versatile application possibilities within a temperature range of -10 to 260°C.

**Simple maintenance**

A maintenance friendly concept allow easy removal of the filter insert, which can be cleaned with compressed air, in an ultrasound bath or by means of a high pressure cleaner. The filter housing remains in the system circuit.

The MPF-80-200 can be supplied with an optional maintenance indicator.

All advantages at a glance:

- Low cost with high filter performance
- Simple maintenance and cleaning
- Suitable for high flow volumes
- Large temperature range

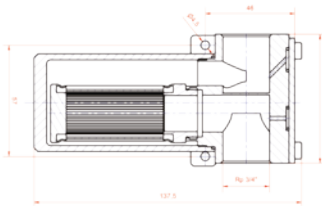

Part No. MPF-F  
Filter insert

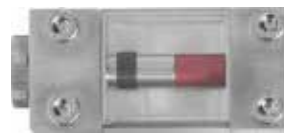

Part No. MPF-M  
Maintenance indicator



Part No. MPF-O  
O-Ring

Technical data	
Material	Stainless steel 1.4305
Connection thread	G 3/4"
Coolant	Water / oil
Pressure range	PN 16
Operating temperature	-10°C / 260°C
Seal	PTFE
Dimensions	76 x 56 x 131 mm (L x W x H)
Weight	approx. 1.3 kg

**Design according to:**

Pressure Equipment Directive 97/23/EU, pressure equipment type acc. to Art.

1: container, fluid acc. to Art. 9: group

2: others acc. to Art. 3, para.

3: good engineering practice, suitable for max. 1,000 full cycle motions.

Filter insert	
Material	Stainless steel 1.4305, adhesive-free, rolled
Mesh width	200 µm
Filter surface	approx. 150 cm <sup>2</sup>
Connection	Thread connector
Dimensions	Ø 32 X 76 mm

Maintenance indicator (optional)	
Principle	Differential pressure measurement
Seal	PTFE O-ring
Dimensions	45 x 30 x 66 mm (L x W x H)

O-Ring	
Material	PTFE
Dimensions	Ø 45 X 1.5 mm

# 03.

## CONSUMABLES

**97**

**03.1 MOULD CLEANER**



**98**

**03.2 MOULD RELEASE**



**99**

**03.3 MOULD PROTECT**



**100**

**03.4 MOULD LUBRICANT**



**102**

**03.5 MOULD POLISH**



**103**

**03.6 NANO MOLD COATING**



**105**

**03.7 PURGING COMPOUND**





**MOULD CLEANER/DEGREASER**



Part No.	Description	Size	
MCD501	Mould Clean - Fast drying	500 ml / 18 oz	12

**Description**

Fast drying Cleaner and Degreaser for removing oil, grease and wax residues from moulds. Supplied in aerosol form, all aerosols are free of fluorocarbons.

**MOULD CLEANER/DEGREASER**



Part No.	Description	Size	
MCD501FG	Mould Clean - Fast drying	500 ml / 18 oz	12

**Description**

Fast drying Cleaner and Degreaser for removing oil, grease and wax residues from moulds. Supplied in aerosol form, all aerosols are free of fluorocarbons.

**CITRUS CLEANER/DEGREASER**



Part No.	Description	Size	
MCD551	Citrus Degreaser - Slow drying	500 ml / 18 oz	12

**Description**

Citrus Based Solvent Degreaser. High performance citrus based cleaning solvent. An ideal alternative to traditional chlorinated or highly volatile solvent cleaners. Slow drying which allows maximum cleaning results. Natural based, high performance cleaner/ degreaser. Fully biodegradable. Deep penetrating action. Classified as non-flammable. Effective on a wide range of soiling such as oil, grease, tar, bitumen, silicones, rubber-based adhesives, oil-based paints, inks and dyes. Safe on metals and most plastics. Pleasant orange Citrus odour.

# MOULD SPRAYS

## MOULD CLEANER/POLYMER REMOVER



Part No.	Description	Size	
MPR501	Mould Clean Polymer Remover	500 ml / 18 oz	12

**Description**

Cleaning agents remove plastic residue from moulds and dies including residues caused by cracking, for example. They provide for time-saving production processes, for dimensional accuracy of plastic parts and mouldings. Specifically designed to remove polymer deposits, plastic, antisoluble resins, grease and oils. Water soluble, highly active organic cleaner. Supplied in aerosol form, all aerosols are free of fluorocarbons.

## ANTISTATIC FOAM CLEANER



Part No.	Description	Size	
MFC501	Foam Cleaner	500 ml / 18 oz	12

**Description**

Mouldpro Foam Cleaner is a unique anti-static foaming cleaner based on a blend of surfactants, solvents, inhibitors and water. Unrivalled in performance, it quickly and easily removes all types of dirt, grease, stains, soiling and other contamination from hard surfaces.

## MOULD RELEASE, SILICON FREE



Part No.	Description	Size	
MRN501	Mould Release Silicone free	500 ml / 18 oz	12

**Description**

Universal Release Agent on a base of Synthetic Oils. A high quality proven release agent that ensures trouble free moulding, saves time, shortens cycles times, reduces scrap and is gentle on dies and moulds. Suitable for thermoplastic or thermoset moulding.

## MOULD RELEASE, SILICON FREE



Part No.	Description	Size	
MRN501FG	Mould Release Silicone free	500 ml / 18 oz	12

**Description**

Universal Release Agent on a base of Synthetic Oils. A high quality proven release agent that ensures trouble free moulding, saves time, shortens cycles times, reduces scrap and is gentle on dies and moulds. Suitable for thermoplastic or thermoset moulding.

**MOULD PROTECT, GREEN**



**PROTECT**

Part No.	Description	Size	
MPG501	Mould Protect Green	500 ml / 18 oz	12

**Description**

Anticorrosion agents provide dismantled die, moulds and parts with long-term protection against corrosions. This ensures that your mould is always ready for use, maintaining value and efficiency. It is not necessary to remove the protective film prior to use. This agent does not creep.

**MOULD PROTECT, CLEAR**



**PROTECT**

Part No.	Description	Size	
MPW501	Mould Protect Clear	500 ml / 18 oz	12

**Description**

Anticorrosion agents provide dismantled die, moulds and parts with long-term protection against corrosions. This ensures that your mould is always ready for use, maintaining value and efficiency. It is not necessary to remove the protective film prior to use. This agent does not creep.

**MOULD PROTECT, CLEAR**



**PROTECT**



Part No.	Description	Size	
MPW501FG	Mould Protect Clear	500 ml / 18 oz	12

**Description**

Anticorrosion agents provide dismantled die, moulds and parts with long-term protection against corrosions. This ensures that your mould is always ready for use, maintaining value and efficiency. It is not necessary to remove the protective film prior to use. This agent does not creep.

**MOULD PROTECT, BLUE**



**PROTECT**



Part No.	Description	Size	
MPB501FG	Mould Protect Blue	500 ml / 18 oz	12

**Description**

Anticorrosion agents provide dismantled die, moulds and parts with long-term protection against corrosions. This ensures that your mould is always ready for use, maintaining value and efficiency. It is not necessary to remove the protective film prior to use. This agent does not creep.

# LUBRICANTS

## EJECTOR PIN LUBRICANT



**LUBRICATE**

Part No.	Description	Size	
MEL501	Ejector Pin Lubricant	500 ml / 18 oz	12

**Description**

Heavy duty clear lubricant for ejector pins and other close tolerance mould parts. Extremely tenacious, clear non-staining film which withstands extreme pressure and friction.  
Operational to 120°C.

## MAINTENANCE LUBRICANT



**LUBRICATE**

Part No.	Description	Size	
MWD501	Maintenance Lubricant	500 ml / 18 oz	12

**Description**

A multi-purpose product for lubricating, cleaning, dewatering, penetrating and corrosion protection. Can be used in endless applications on all metallic surfaces including moulds, chains, gears, tools, locks, etc.

**Features:**

- Long Lasting Lubrication
- Moisture Displacement
- Forms a temporary anti-corrosion coating
- Penetrates rust and corrosion
- Contains PTFE for improved lubrication and load resistance

**EJECTOR PIN LUBRICANT - FOOD GRADE**



Part No.	Description	Size	
MLF500	Ejector Pin Grease	0,5 kg	1

**Description**

Non-soiling lubricants that keep moving parts running smoothly and prevent damage due to breakage and seizing. For Slides and Ejector Pins. Thin-film lubrication, Food Grade, long term action, good protection from corrosion. Operating Temperature - upto 270°C

**EJECTOR PIN LUBRICANT - FOOD GRADE**



Part No.	Description	Size	
MLF080	Ejector pin Grease	80 ml.	1

**Description**

Non-soiling lubricants that keep moving parts running smoothly and prevent damage due to breakage and seizing. For Slides and Ejector Pins. Thin-film lubrication, Food Grade, long term action, good protection from corrosion. Operating Temperature - upto 270°C .

**COPPER ANTI-SEIZE**



Part No.	Description	Size	
MCS500	Copper Assembly Compound	0,5 kg	1

**Description**

Mouldpro Copper Anti-Seize ensures rapid and easy assembly of threaded parts. It allows correct torque to be applied by eliminating thread interference. Mouldpro Copper Anti-Seize paste prevents seizing and galling and gives quick and easy breakout of threads, gaskets and packings even after long exposure to high temperature, corrosive conditions or extreme surface pressures. It also reduces wear in areas of high friction. Temperature up to 1.100°C

## MOULD POLISH

### COPPER ANTI-SEIZE



**LUBRICATE**

Part No.	Description	Size	
MCS080	Copper Assembly Compound	80 ml.	1

**Description**

Mouldpro Copper Anti-Seize ensures rapid and easy assembly of threaded parts. It allows correct torque to be applied by eliminating thread interference. Mouldpro Copper Anti-Seize paste prevents seizing and galling and gives quick and easy breakout of threads, gaskets and packings even after long exposure to high temperature, corrosive conditions or extreme surface pressures. It also reduces wear in areas of high friction. Temperature up to 1.100°C

## MOULD POLISH



**POLISH**



Part No.	Description	Size	
MCP080	Mould Polish Paste	80 ml.	1

**Description**

This superior, quality Mould polish is perfect for cleaning and polishing steel moulds. It safely and easily removes oxidation, corrosion, stains, and rust. It produces a brilliant reflective luster and leaves an invisible protective coating to ensure a long-lasting shine..

### SPRAY CAN HOLDER



Part No.	Number of cans	Length	
MCH02	2	170 mm	1
MCH03	3	250 mm	1
MCH04	4	330 mm	1

**NANOMOLDCOATING®**

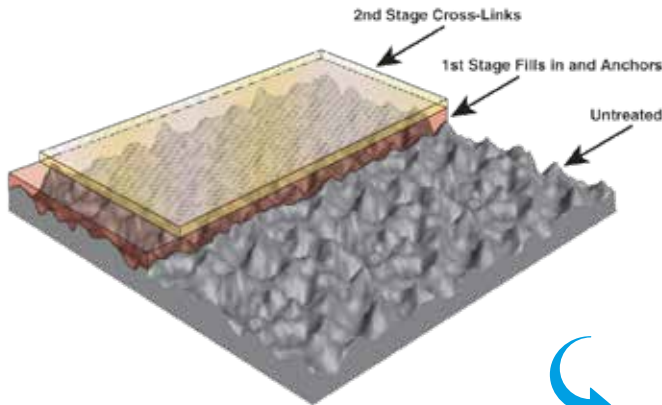

**RELEASE**

Type	HC-Heat Cure	"HCF-Heat Cure FDA Compliant"	QC-Quick Cure	"QCru-Quick Cure Rubber"	"QCsi-Quick Cure Silicone"
Part No.	HC-5ml	HCF-5ml.	QC	QCRU	QCSI
Excellent Release	•	•	•	•	•
Thermoplastics all grades	•	•	•		
Rubber				•	
Silicone					•
Cure time 10-15 min.			•	•	•
Cure time 3-4 hours.	•	•			
Cured with hot air	•	•			
Cured by heating mould			•	•	•
Application on cold surface	•	•			
Application on heated surface			•	•	•
Bonds on pre-treated surfaces			•	•	•
Multiple coats are possible	•	•	•	•	•
Solvent Carrier	•	•			
Water Carrier			•	•	•
Polymer film	•	•			
Flouropolymer film			•	•	•
Up to 500K Cycles	•	•	•	•	•
May require frequent reapplication			•	•	•
Temperatures up to 250°C	•	•	•	•	•
Temperatures up to 540°C	•	•			
Bottle net volume	5ml.	5ml.	60ml.	60ml.	60ml.

**Benefits for your Production**

- Up to 500,000 cycles per coating
- Reduces cycle times, increases productivity & eliminates sticking
- In-house/Self applied application
- Improves part quality
- Improves part finish by eliminated dragging and stretching
- Reduces moulding pressure and temperature
- Reduction in part weight due to lower packing pressures
- Does not migrate to part surface
- Can be used for virtually any moulded material
- Kits include everything for the application
- Non-toxic



# Changing Colour?



**NSF**<sup>®</sup>

## MOULDPRO PURGING COMPOUNDS

### Benefits:

#### Universal Application

Mouldpro offers cleaning compounds for any polymer application. Choose between Ready-to-use or pure Concentrate.

#### Economical and Efficient

All our cleaning compounds offer best cleaning process and lowest cleaning price.

**ASK ONE OF OUR  
PURGING EXPERTS  
TODAY FOR MORE  
INFORMATION**



**PURGING COMPOUND**



Part No.	Product	Size	Injection Moulding	Blow Moulding	Pass filter	Hot runner suitable	NSF registered	Polyolefins	PS	SAN, ABS, ASA	PVC	PTFE, PVDF	PMMA	POM	PAG, PA66, PA610, PA11, PA12	PC, PC/ABS	PET, PBT	PPO, PEEK, PPS, PES, PSU, LCP	CA, CAB, CP	TPU, TPE	Temperature range high 300C	Temperature range 120-300C
MC200	MasterClean	20 kg	•	□	•	•	•	•	•	•	•	•	•	•	•	•	•	•	•	•	•	•
MP1X	MultiPurge	1 kg	•	•	•	•	•	•	•	•	•	•	•	•	•	•	•	•	•	•	•	•
MP5X	MultiPurge	5 kg	•	•	•	•	•	•	•	•	•	•	•	•	•	•	•	•	•	•	•	•
MP10X	MultiPurge	10 kg	•	•	•	•	•	•	•	•	•	•	•	•	•	•	•	•	•	•	•	•
MP20X	MultiPurge	20 kg	•	•	•	•	•	•	•	•	•	•	•	•	•	•	•	•	•	•	•	•

**Description**

Ready to use Compounds. Safe and fast cleaning of screws, cylinders and nozzles.

- Highly recommended
- Medium recommended
- Suitable

**MasterClean**

Ready-to-use granular purging compound for the cleaning of screws, cylinders, machine nozzles and hot runners.

**Features**

- Quick Colour Changes
- Quick Material Changes
- Effective removal of Carbon (Black Spots)
- Effective Shut Down Medium for Heat Sensitive Materials

**Benefits**

- Easy to Use – Follow the simple Instructions
- Reduced Downtime – Fast and Effective Operation means faster changeovers
- Non Abrasive – Our purging compound is a high grade polymer with additives containing no abrasives
- Clean – A high quality product that generates No Smoke, Vapour or Odours during operation.
- Economical – Only a small amount of purging compound is required this combined with Fast and Effective Operation means lower downtime and increases productivity.

**MultiPurge**

MultiPurge is a cleaning compound concentrate in pellets, which can be mixed (10%) with any type of virgin thermoplastics, especially engineered to clean barrel, screw, nozzle and hot runners from carbon residuals, deposits, incrustations in changing colour and material.

**ONE Purge Agent for ALL Polymers!**

By mixing with virgin materials, the original temperature settings can be used to ensure optimized cleaning conditions.

- Temperature range: 80°C up to 420°C.
- MultiPurge is odorless, non-toxic; it doesn't contain solvents and it isn't abrasive.
- All components of MultiPurge are qualified as Generally Recognized as Safe (GRAS) by FDA.
- MultiPurge is environmentally safe.
- MultiPurge is EXTREMELY economical
- Food Grade – NSF Approved

# 04.

## TEMPERATURE CONTROL

**107**

04.1 HOT RUNNER  
CONTROLLER



**108**

04.2 HEATER BANDS



**111**

04.3 THERMOCOUPLES

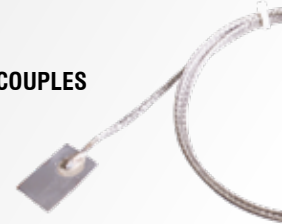

**114**

04.4 CONNECTORS



**121**

04.5 CABLES



**122**

04.6 THERMOMETERS



The advanced modules which include current monitoring as standard have the following features:

- Dehumidifying Soft Start
- Triple-line LED display
- Auto / Manual Output Function
- PID Auto Tune Temperature Control
- Max Current Output 15A
- Current Measurement Display
- Power Output Percentage Display
- Thermocouple J/K Type
- Temperature scale °F/°C Switchable
- Selectable Alarm Modes
- Phase Angle Output Mode
- Zero Cross output Mode
- Fuse Failure Indicator
- Heater Break Detection
- Power Frequency Auto-Detection (50/60Hz)
- Thermocouple Failure Detection
- Thermocouple Reverse Detection
- Current Monitoring Display
- Alarm Output Option
- RS485 Output Option



**HOT RUNNER CONTROLLER UNITS**

Modular Hot Runner Controllers comprising a range of robust steel mainframe cabinets supplied complete with Industry Standard control modules.

- 380-400VAC/3Phase/N/Earth
- CE Marked
- Supplied Complete with 3m Cable Set

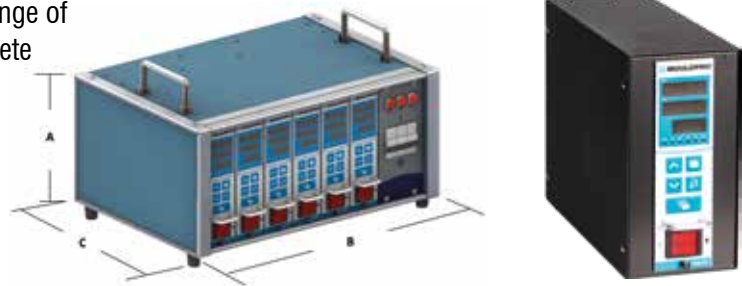

Part No.	Number Zones	Cabinet Dimensions			Cable/Connector
		A	B	C	
HRC001	Single Zone	188	96	248	1 x 4 pin
HRC002	2 Zones	215	224	299	1 x 16 pin
HRC004	4 Zones	215	325	299	1 x 16 pin
HRC006	6 Zones	215	427	299	1 x 24 pin
HRC008	8 Zones	215	529	299	2 x 16 pin
HRC012	12 Zones	215	733	299	2 x 24 pin

**MODULE**

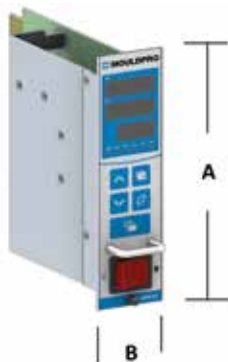



Part No.	Number Zones	A	B
HRM15C	Single Zone	176	50

# HEATER BANDS

## NOZZLE HEATER SELECTION GUIDE



Mouldpro offers two types of nozzle band heaters, for reliable and powerful heating of the nozzles on injection moulding machines. Both heater types are CE marked and made of premium quality materials.

	NHB Type	Z17 Type
		
<b>Application</b>		
Wattage Load	6 W/cm <sup>2</sup>	8 W/cm <sup>2</sup>
Working Temperatures	370°C	400°C
Standard Voltage feeding	230 V.	230 V.
Cable Type	SS-Bipolar	SS-Bipolar+ Earth
Cable Length	1000 mm.	1000 mm.
Cable Exit	Super Flex	45°
Insulation	Mica	Mica
Sealed construction	No	Yes
Lifetime	✓	✓✓✓
<b>Description</b>	The NHB Type is normally used when space around the nozzle is limited (near gate or hotrunners) and the flexible cables allows compact installation. The electric connection between the heater and the feeding cables is integrated into the internal heating element.	The high quality Stainless Steel sealed heater is the perfect solution, when high performance and power is required. The Z17 heaters are made of Stainless Steel Tube which ensures a solid construction and is resistant to corrosive action and hermetically sealed to avoid any plastic seepage.

**STAINLESS STEEL NOZZLE HEATERS**

STAINLESS  
STEEL

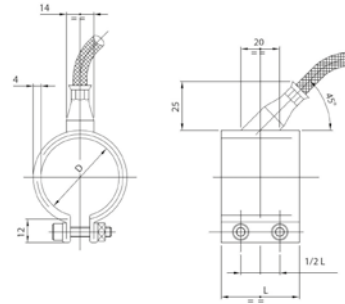

Part No.	Ø ID	Length	Watt
Z17025030	25	30	130
Z17030020	30	20	100
Z17030025	30	25	130
Z17030030	30	30	170
Z17030035	30	35	200
Z17030040	30	40	230
Z17035025	35	25	160
Z17035030	35	30	200
Z17035035	35	35	240
Z17035040	35	40	270
Z17035045	35	45	310
Z17040020	40	20	160
Z17040025	40	25	190
Z17040030	40	30	230
Z17040035	40	35	270
Z17040040	40	40	310
Z17040045	40	45	350
Z17045025	45	25	210
Z17045030	45	30	260
Z17045035	45	35	310
Z17045040	45	40	350
Z17045045	45	45	400
Z17045050	45	50	450
Z17045055	45	55	490
Z17050020	50	20	190
Z17050025	50	25	240
Z17050030	50	30	290
Z17050035	50	35	340
Z17050040	50	40	390
Z17050050	50	50	500
Z17050060	50	60	600
Z17055020	55	20	210
Z17055025	55	25	270
Z17055030	55	30	320
Z17055035	55	35	380
Z17055040	55	40	430
Z17055050	55	50	540
Z17060020	60	20	230
Z17060025	60	25	290
Z17060030	60	30	350
Z17060035	60	35	410
Z17060040	60	40	470
Z17060050	60	50	600
Z17060060	60	60	720
Z17065020	65	20	250
Z17065025	65	25	320
Z17065030	65	30	380
Z17065035	65	35	450
Z17065040	65	40	520
Z17065050	65	50	650

Part No.	Ø ID	Length	Watt
Z17070020	70	20	270
Z17070025	70	25	340
Z17070030	70	30	410
Z17070035	70	35	490
Z17070040	70	40	560
Z17070050	70	50	700
Z17070060	70	60	840
Z17075020	75	20	290
Z17075025	75	25	370
Z17075030	75	30	440
Z17075035	75	35	520
Z17075040	75	40	560
Z17075050	75	50	750
Z17075060	75	60	900
Z17080020	80	20	310
Z17080025	80	25	390
Z17080030	80	30	470
Z17080035	80	35	560
Z17080040	80	40	640
Z17080050	80	50	800
Z17080060	80	60	960
Z17085020	85	20	330
Z17085025	85	25	420
Z17085030	85	30	500
Z17085035	85	35	590
Z17085040	85	40	680
Z17085050	85	50	850
Z17085060	85	60	1020
Z17090020	90	20	350
Z17090025	90	25	440
Z17090030	90	30	540
Z17090035	90	35	630
Z17090040	90	40	720
Z17090050	90	50	900
Z17090060	90	60	1080
Z17095020	95	20	370
Z17095025	95	25	470
Z17095030	95	30	570
Z17095035	95	35	660
Z17095040	95	40	760
Z17095050	95	50	950
Z17095060	95	60	1150
Z17100020	100	20	380
Z17100025	100	25	500
Z17100030	100	30	600
Z17100035	100	35	700
Z17100040	100	40	800
Z17100050	100	50	1000
Z17100060	100	60	1200

**Description**  
 Sealed nozzle heater high Wattage  
 Supplied with 1000 mm Lead  
 230 V. Working Temperature max 380/400°C

# HEATER BANDS

## MICA NOZZLE HEATERS

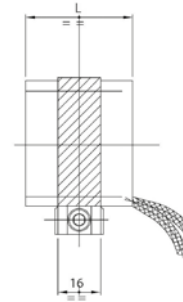
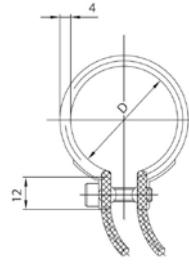

Part No.	Ø ID	Length	Watt
NHB25x25	25	25	120
NHB25x30	25	30	120
NHB25x32	25	32	120
NHB25x35	25	35	130
NHB25x38	25	38	140
NHB25x40	25	40	150
NHB25x45	25	45	165
NHB25x50	25	50	180
NHB30x25	30	25	120
NHB30x30	30	30	130
NHB30x32	30	32	140
NHB30x35	30	35	150
NHB30x38	30	38	160
NHB30x40	30	40	175
NHB30x45	30	45	200
NHB30x50	30	50	220
NHB32x25	32	25	115
NHB32x30	32	30	140
NHB32x32	32	32	150
NHB32x35	32	35	160
NHB32x38	32	38	175
NHB32x40	32	40	180
NHB32x45	32	45	200
NHB32x50	32	50	230
NHB35x25	35	25	130
NHB35x30	35	30	150
NHB35x32	35	32	160
NHB35x35	35	35	175
NHB35x38	35	38	190
NHB35x40	35	40	200
NHB35x45	35	45	225
NHB35x50	35	50	250

Part No.	Ø ID	Length	Watt
NHB38x25	38	25	140
NHB38x30	38	30	160
NHB38x32	38	32	170
NHB38x35	38	35	190
NHB38x38	38	38	200
NHB38x40	38	40	225
NHB38x45	38	45	270
NHB38x50	38	50	275
NHB40x25	40	25	140
NHB40x30	40	30	175
NHB40x32	40	32	180
NHB40x35	40	35	200
NHB40x38	40	38	220
NHB40x40	40	40	230
NHB40x45	40	45	250
NHB40x50	40	50	280
NHB45x25	45	25	160
NHB45x30	45	30	185
NHB45x32	45	32	200
NHB45x35	45	35	225
NHB45x38	45	38	200
NHB45x40	45	40	250
NHB45x45	45	45	275
NHB45x50	45	50	325
NHB50x25	50	25	180
NHB50x30	50	30	220
NHB50x32	50	32	235
NHB50x35	50	35	250
NHB50x38	50	38	280
NHB50x40	50	40	300
NHB50x45	50	45	325
NHB50x50	50	50	375

### Description

Mica insulated heater, Supplied with 1000 mm Lead 230 V  
Working Temperature max 350/370°C

**THERMOCOUPLE LEAF TYPE**



Part No.	Length	Width	Type	Leads
TLC	20	10	J	1000 mm

**Description**  
 Thermocouple leaf type, ideal for nozzle bands.  
 Leads: 1000 mm

**THREADED TYPE**

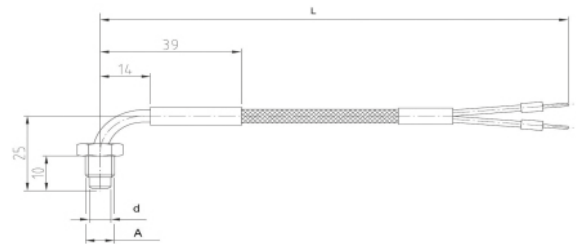

Part No.	d	D	L
MTT602000	6	M8x1	2500

**Description**  
 Fe-CuNi, Type J, max temperature 400°C

**SURFACE WASHER TYPE**

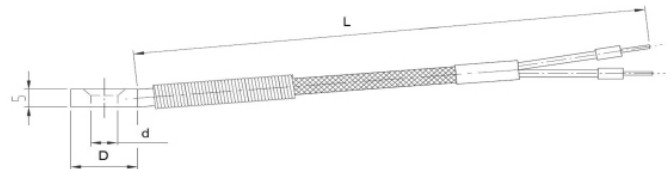

Part No.	d	D	L
MTS602000	6,5	16	2500

**Description**  
 Fe-CuNi, Type J, max temperature 400°C

# THERMOCOUPLES

## PIN TYPE

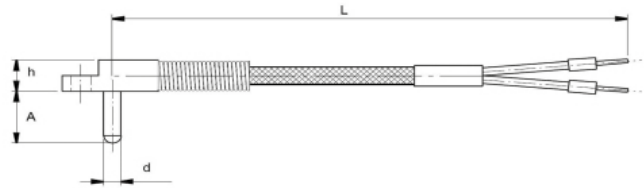

Part No.	d	A	h	L
MTP402000	4	12	8	2500

**Description**  
Fe-CuNi, Type J, max temperature 400°C

## BAYONET - 2 PINS

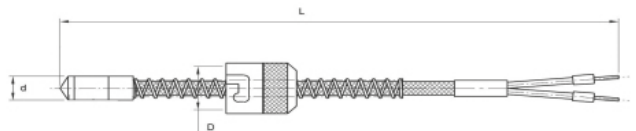

Part No.	d	D	L
MTB48102000	4,8	11	2500
MTB60102000	6	11	2500
MTB60122000	6	12,8	2500
MTB60142000	6	15	2500
MTB80122000	8	12,8	2500
MTB80142000	8	15	2500

**Description**  
Fe-CuNi, Type J, max temperature 400°C



**ADAPTORS**

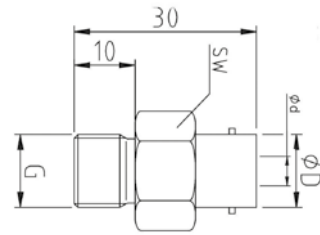

Part No.	∅D	∅d	SW	G
MTA12M10X1	12	7,1	17	M10x1
MTA12M12X1	12	8,2	16	M12x1
MTA12M12X1,75	12	8,2	16	M12x1,75
MTA12M14x1,5	12	8,2	16	M14x1,5
MTA12G3/8	12	8,2	17	G3/8
MTA14M10X1	14	7,1	17	M10x1
MTA14M12X1	14	8,2	17	M12x1
MTA14M12X1,75	14	8,2	17	M12x1,75
MTA14M14X1,5	14	8,2	17	M14x1,5
MTA14G1/4	14	8,2	17	G1/4
MTA14G3/8	14	8,2	17	G3/8

**EXTENDED ADAPTORS**

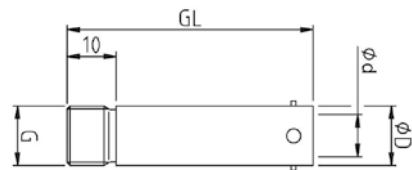

Part No.	∅D	∅d	G	GL
MTG10M10X1	10	7,1	M10x1	30
MTG10M10X1,5	10	7,1	M10x1,5	30
MTG10G1/8	11	6,3	G1/8	30
MTG12M10X1	12	7,1	M10x1	50
MTG12M10X1,5	12	7,1	M10x1,5	50
MTG12M12X1	12	8,2	M12x1	50
MTG12M12X1,75	12	8,2	M12x1,75	50
MTG12M14X1,5	12	8,2	M14x1,5	50
MTG14M12X1	14	9	M12X1	50
MTG14M14x1,5	14	9	M14x1,5	50

# CONNECTORS

## MULTIPOLE CONNECTORS



High quality connectors, compatible with Industry Standard (equivalent products from other manufacturers)

- CE marked
- UL/CSA approved
- Quality Screw terminals
- Cost efficient
- Full range
- Protection standard: IP20
- Seals: NBR
- Temperature range: 125°C (CK type only 100°C)

**INSERTS MALE**

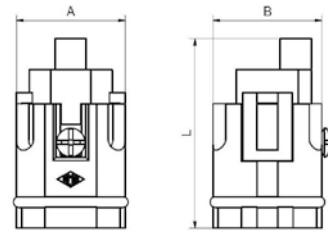

Part No.	# Poles	A	B	L
CKM03	3+E	21	21	30,5
CKM04	4+E	21	21	36,5

**INSERTS FEMALE**

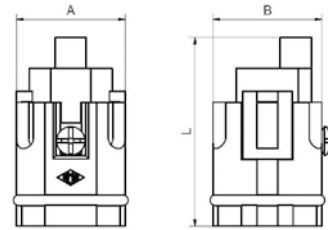

Part No.	# Poles	A	B	L
CKF03	3+E	21	21	30,5
CKF04	4+E	21	21	36,5

**STRAIGHT HOOD**

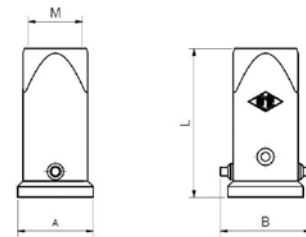

Part No.	# Poles	Levers	A	B	L	M
MKAV20	3/4+E	Single	28	33,5	60,5	M20

**PANEL MOUNT BASE**

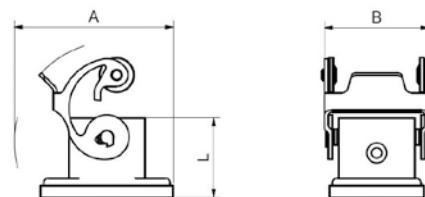

Part No.	# Poles	Levers	A	B	L
CKAX03I	3/4+E	Single	57,5	32	24

# CONNECTORS

## INSERTS MALE, SCREW TERMINALS

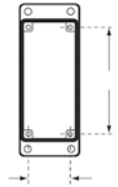
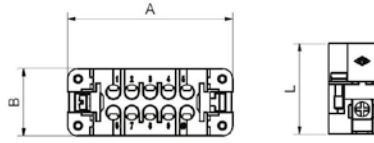

Part No.	# Poles	A	B	L	Size
CDAM10	10 Pole	56,5	23	31	49.16
CDAM16	16 Pole	73	23	31	66.16

## INSERTS FEMALE, SCREW TERMINALS

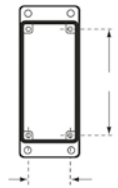
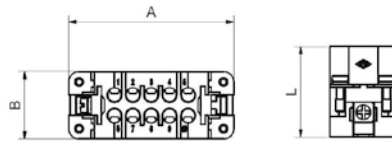

Part No.	# Poles	A	B	L	Size
CDAF10	10 Pole	56,5	23	31	49.16
CDAF16	16 Pole	73	23	31	66.16

## INSERTS MALE, 3 ROW, HIGH DENSITY CRIMP TERMINAL

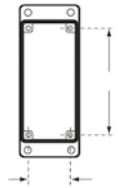
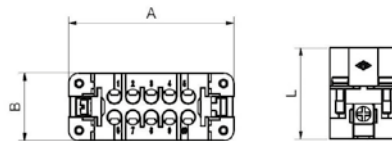
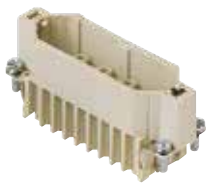

Part No.	# Poles	A	B	L	Size
CDM25	25 Pole	73	23	31	66.16

## INSERTS FEMALE, 3 ROW, HIGH DENSITY CRIMP TERMINAL

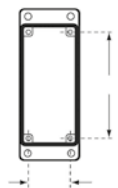
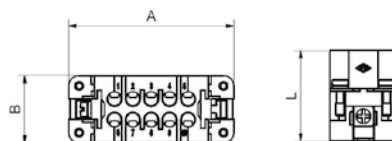
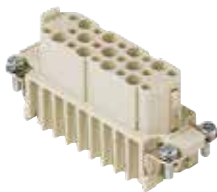

Part No.	# Poles	A	B	L	Size
CDF25	25 Pole	73	23	31	66.16

## CRIMP PINS

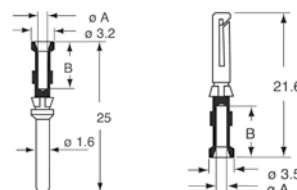

Part No.	Type	Wire Size	ø-A	ø-B
CDMA0.5	Male	0,5 mm <sup>2</sup>	1,1	8
CDA0.5	Female	0,5 mm <sup>2</sup>	1,1	8
CDMA1.5	Male	1,5 mm <sup>2</sup>	1,8	8
CDA1.5	Female	1,5 mm <sup>2</sup>	1,8	8

**TOP ENTRY HOOD**

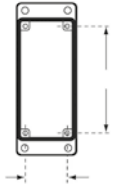
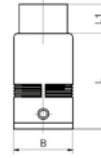
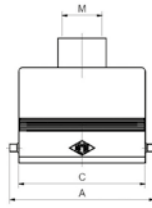

Part No.	# Poles	Levers	A	B	C	L	L1	M	Size
MZAV15L20	10 Pole	Single	72	36	63	64,5	14,5	M20	49.16
MZAV25L20	16/25 Pole	Single	88,5	36	79,5	70,5	14,5	M20	66.16
MZAV25L25	16/25 Pole	Single	88,5	36	79,5	70,5	14,5	M25	66.16

**SIDE ENTRY HOOD**

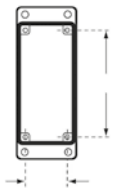
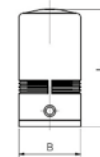
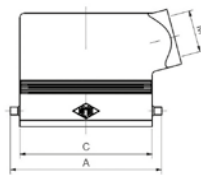

Part No.	# Poles	Levers	A	B	C	L	M	Size
MZO15L20	10 Pole	Single	72	29,4	63	55,9	M20	49.16
MZO25L25	16 Pole	Single	88,5	29,4	79,5	55,9	M25	66.16
MZA025L25	25 Pole	Single	88,5	29,4	79,5	70,5	M25	66.16

**PANEL MOUNT HOUSING**

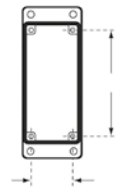
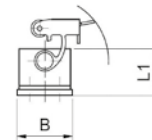
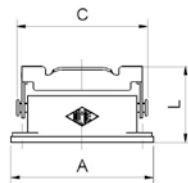

Part No.	# Poles	Levers	A	B	C	L	Size
CZI15L	10 Pole	Single	83	32	76	44	49.16
CZI25L	16/25 Pole	Single	98	32	93	44	66.16

**SURFACE MOUNT HOUSING**

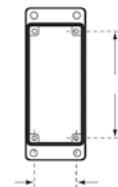
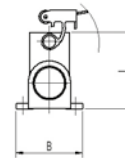
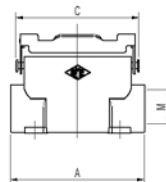

Part No.	# Poles	Levers	A	B	C	L	M	Size
MZP15L25	10 Pole	Single	85	50	76	52	M25	49.16
MZAP25L25	16/25 Pole	Single	101	50	93	57	M25	66.16

# CONNECTORS

## INSERTS MALE

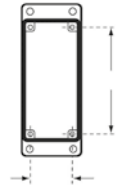
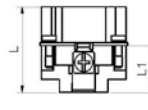
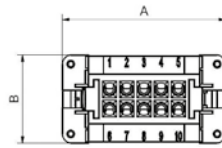

Part No.	# Poles	A	B	L	L1	Size
CNEM06T	6 Pole	50	34	33	18	44.27
CNEM10T	10 Pole	63,4	34	33	18	57.27
CNEM16T	16 Pole	83,5	34	33	18	77.27
CNEM24T	24 Pole	110,3	34	33	18	104.27

## INSERTS FEMALE

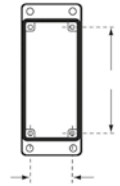
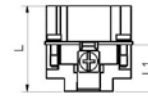
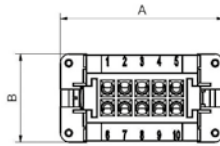

Part No.	# Poles	A	B	L	L1	Size
CNEF06T	6 Pole	50	34	33	18	44.27
CNEF10T	10 Pole	63,4	34	33	18	57.27
CNEF16T	16 Pole	83,5	34	33	18	77.27
CNEF24T	24 Pole	110,3	34	33	18	104.27

## TOP ENTRY HOOD, SINGLE LEVER

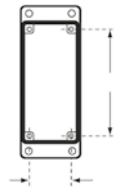
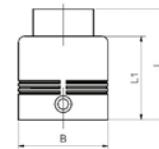
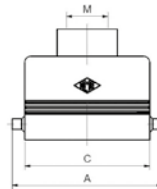

Part No.	# Poles	Levers	A	B	C	L	L1	M	Size
MHV06L20	6 Pole	Single	72	43	60	53	40	M20	44.27
MHV10L20	10 Pole	Single	87	43	73	58	45	M20	57.27
MHV16L25	16 Pole	Single	108	43	93,5	58	45	M25	77.27
MHV24L32	24 Pole	Single	135	43	120	68	55	M32	104.27

## SIDE ENTRY HOOD, SINGLE LEVER

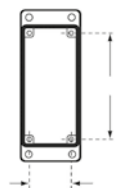
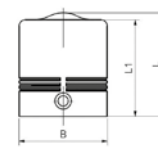
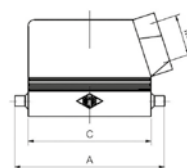

Part No.	# Poles	Levers	A	B	C	L	L1	M	Size
MHO06L20	6 Pole	Single	73	43	60	50,4	47	M20	44.27
MHO10L20	10 Pole	Single	87	43	73	52	49	M20	57.27
MHO16L25	16 Pole	Single	108	43	93,5	63	60	M25	77.27
MHO24L32	24 Pole	Single	135	43	120	63	60	M32	104.27

**PANEL MOUNT BASE, SINGLE LEVER**

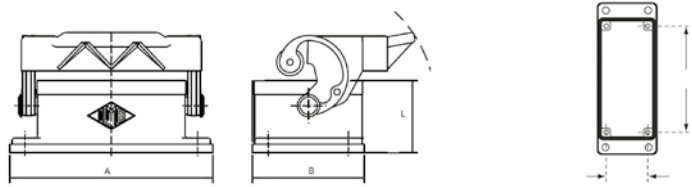

Part No.	# Poles	Levers	A	B	L	Size
CHI06L	6 Pole	Single	82,5	45,5	29	44.27
CHI10L	10 Pole	Single	95,5	45,5	29	57.27
CHI16L	16 Pole	Single	115,5	45,5	29	77.27
CHI24L	24 Pole	Single	142,5	45,5	29	104.27

**SURFACE MOUNT BASE, SINGLE LEVER**

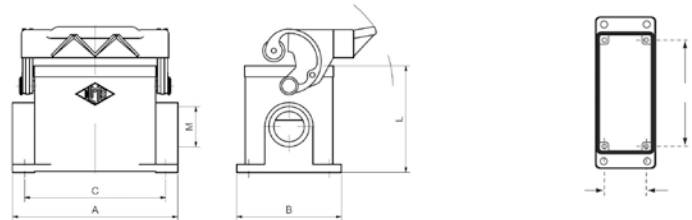

Part No.	# Poles	Levers	A	B	C	L	M	Size
MHP06L20	6 Pole	Single	82	52	70	53	M20	44.27
MHP10L20	10 Pole	Single	93,5	52	82	57	M20	57.27
MHP16L25	16 Pole	Single	117	57	105	63	M25	77.27
MHP24L25	24 Pole	Single	144	57	132	63	M25	104.27

**TOP ENTRY HOOD, DOUBLE LEVER**

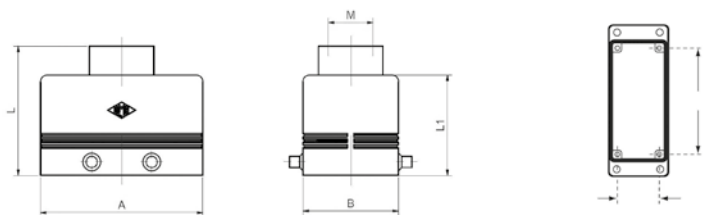

Part No.	# Poles	Levers	A	B	L	L1	M	Size
MHV10.20	10 Pole	Double	73	43	58	45	M20	57.27
MHV16.25	16 Pole	Double	93,5	43	58	45	M25	77.27
MHV24.32	24 Pole	Double	120	43	68	55	M32	104.27

## CONNECTORS

### SIDE ENTRY HOOD, DOUBLE LEVER

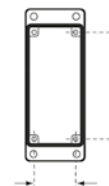
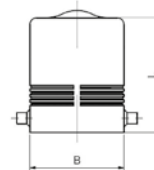
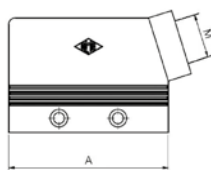

Part No.	# Poles	Levers	A	B	L	M	Size
MHO10.20	10 Pole	Double	73	43	52	M20	57.27
MHO16.25	16 Pole	Double	93,5	43	63	M25	77.27
MHO24.32	24 Pole	Double	120	43	63	M32	104.27

### PANEL MOUNT BASE, DOUBLE LEVER

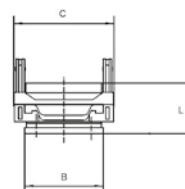
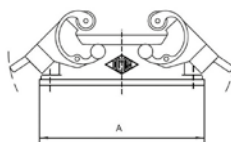

Part No.	# Poles	Levers	A	B	C	L	Size
CHI10	10 Pole	Double	95,5	45,5	58	29	57.27
CHI16	16 Pole	Double	115,5	45,5	58	29	77.27
CHI24	24 Pole	Double	142,5	45,5	58	29	104.27

### SURFACE MOUNT BASE, DOUBLE LEVER

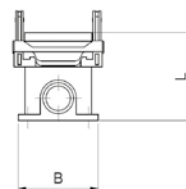
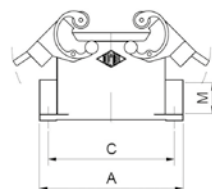

Part No.	# Poles	Levers	A	B	C	L	M	Size
MHP10.20	10 Pole	Double	93,5	52	82	57	M20	57.27
MHP16.25	16 Pole	Double	117	57	105	63	M25	77.27
MHP24.25	24 Pole	Double	144	57	132	63	M25	104.27

### CABLE GLANDS



Part No.	Thread
AGM20T	M20
AGM25T	M25
AGM32T	M32



**POWERFLEX CABLE**



Part No.	Zones	Cores	Coil Length
PF08	8	16 + E	20m
PF12	12	24 + E	20m

**Description**  
 Multicore Power Cable  
 1.5mm<sup>2</sup> 16A Cable  
 Numbered Cores, Green/Yellow Earth

**THERMOFLEX CABLE**



Part No.	Zones	Cores	Coil Length
TF08	8	8 Pair + E	20m
TF12	12	12Pair + E	20m

**Description**  
 Multi-core Thermocouple Cable  
 Type J Fe/Cu-Ni, Twisted Pairs  
 DIN Standard Colours (Black/White), Numbered Cores  
 Screen and Earth

**MULTIFLEX CABLE**



Part No.	Zones	Cores	Coil Length
MF06	6	12 + E PWR / 6 Pair T/C	20m

**Description**  
 6 Zone Combination power and thermocouple cable  
 Extremely Flexible  
 1.5mm<sup>2</sup> 16A Power Cable  
 Type J Fe/Cu-Ni Thermocouple Cable, Twisted Pairs  
 DIN Standard Colours (Black/White), Numbered Cores  
 Screen and Earth

# THERMOMETERS

## THERMOMETER KIT



**Part No.**  
826-32

**Temperature range**  
-50°C to + 1300°C

**Description**

Single Input K-Type thermometers offer high accuracy and fast response times; ideal for plastics processors  
 -50° to +1300°  
 °C / °F Selectable  
 Resolution: 0.1°C / 0.1°F  
 Sampling rate of 2.5 times per second  
 Auto Power Off  
 Supplied with carry case, rubber holster & battery  
 Kit Includes: Thermometer (Single Input), Case, Needle Point Penetration Probe, Right Angle Surface probe, Batteries

## DELUXE THERMOMETER KIT



**Part No.**  
826-33

**Temperature range**  
-50°C to + 480°C/1300°C

**Description**

Dual Input K-Type thermometers offer high accuracy and fast response times; ideal for plastics processors  
 50° to 1300°  
 °C / °F Selectable  
 Resolution: 0.1°C / 0.1°F  
 Sampling rate of 2.5 times per second  
 Auto Power Off  
 Supplied with carry case, rubber holster & battery  
 Kit Includes: Thermometer (Single Input), Case, Needle Point Penetration Probe, Right Angle Surface probe, Magnetic Surface Probe, Batteries

## THERMOMETER



**Part No.**  
DT6101K  
DT6102K

**Input**  
Single  
Dual

**Temperature range**  
-50°C to + 1300°C  
-50°C to + 1300°C

**Description**

Single or Dual Input K-Type thermometers offer high accuracy and fast response times; ideal for plastics processors  
 -50° to +1300°  
 °C / °F Selectable  
 Resolution: 0.1°C / 0.1°F  
 Sampling rate of 2.5 times per second  
 Auto Power Off  
 Supplied with carry case, rubber holster, bead probe & battery

**INFRARED AND PROBE THERMOMETER KIT**



**Part No.**  
826-31

**Temperature range**  
-60°C to +480°C

**Description**

Ideal for all temperature measurement requirements around the mouldshop this dual purpose infrared thermometer also has a Type K thermocouple input socket. The kit is supplied in a case complete with penetration probe and 90° ribbon surface probe. Ideal for measuring surface temperature of moulded parts, mould surface temperature or melt temperature.  
 Range (Infrared) -60°C to +480°C  
 Range (Thermocouple) -60°C to +480°C  
 Backlit LCD display  
 Laser Pointer  
 Auto power off (60 secs)  
 Adjustable Emissivity

**HANDHELD 90 DEGREE RIBBON SURFACE PROBE**



**Part No.**  
TCP-RS90-K

**Type**  
K

**Max Temp**  
500°C

**Lead Type**  
Flexible

**HANDHELD PENTRATION PROBE**



**Part No.**  
TCP-PK

**Type**  
K

**Max Temp**  
500°C

**Lead Type**  
Flexible

**MAGNETIC SURFACE PROBE**



**Part No.**  
TCP-R-M

**Type**  
K

**Max Temp**  
500°C

**Lead Type**  
Flexible

# 05.

## MATERIAL HANDLING

### 125

05.1 LOADER HOSES



### 126

05.2 HOT AIR HOSES



### 127

05.3 HOSE CLAMPS



### 132

05.4 CAMLOCK COUPLINGS ALUMINUM



### 132

05.4 VACUUM COUPLERS



### 135

05.5 HOPPER MAGNETS

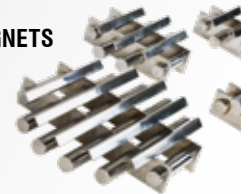

### 135

05.6 MATERIAL SCOOPS



### 136

05.7 BALANCES AND MOISTURE ANALYSER



**ANTI-STATIC PU HOSE/PVC HELIX**



Part No.	Ø ID (mm)	Min Wall thickness (mm)	Roll Length (m)	Wire Clip Ref
PUP38	38	0,5	10	3030250
PUP40	40	0,5	10	3030250
PUP45	45	0,5	10	3030269
PUP50	50	0,5	10	3030285
PUP60	60	0,5	10	3030306

**Description**

Anti-Static Polyurethane hose reinforced with rigid PVC spiral helix and copper wire  
 Inside surface perfectly smooth, outside corrugated  
 Excellent flexibility  
 Light abrasion resistance  
 Operating temperature -20°C to +80°C  
 10m Coil

**PU HOSE/STEEL HELIX**



Part No.	Ø ID (mm)	Min Wall thickness (mm)	Roll Length (m)	Wire Clip Ref
PURH32	32	1,5	10	3030242
PURH38	38	1,5	10	3030250
PURH40	40	1,5	10	3030250
PURH45	45	1,5	10	3030269
PURH50	50	1,5	10	3030285
PURH60	60	1,5	10	3030306

**Description**

Polyurethane hose reinforced with a copper covered steel helix  
 Very high resistance to abrasions  
 Excellent flexibility  
 Smooth Bore  
 Operating temperature -40°C to +80°C  
 10m Coil

**PVC HOSE**



Part No.	Ø ID (mm)	Ø OD (mm)	Roll Length	Clamp Ref.
PAPVC19	20	27	30	HDC2325
PAPVC25	25	33	30	HDC3134
PAPVC31	32	40,4	30	HDC3740
PAPVC38	38	47	30	HDC4347
PAPVC50	50	60	30	HDC5963
PAPVC64	64	74,8	30	HDC7379
PAPVC75	76	88,2	30	HDC8591

**Description**

Clear PVC Hose with a steel spiral helix  
 Excellent flexibility  
 Inside & Outside smooth  
 Operation temperature -10°C to + 60°C  
 30 m Coil

## HOT AIR HOSES

### SILICON DRYER HOSE



Part No.	Ø ID (mm)	Roll Length (m)	Wire Clip Ref
SIL132	32	4	3030200
SIL138	38	4	3030226
SIL141	41	4	3030234
SIL151	51	4	3030269
SIL160	60	4	3030285
SIL170	70	4	3030306

**Description**

Coated glass fabric - Single Ply  
 Operating Temperature -60°C to +250°C  
 4 Metre Length

**HOSE CLAMPS HEAVY DUTY**

STAINLESS  
STEEL

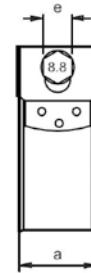
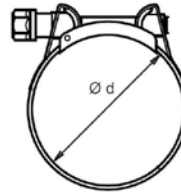

Part No.	Ø	e	a		Hose ref.
HDC2325	23-25	8	18	50	PAPVC19
HDC3134	31-34	11	20	50	PAPVC25
HDC3740	37-40	11	20	50	PAPVC31
HDC4347	43-47	11	20	50	PAPVC38
HDC5963	59-63	11	20	25	PAPVC50
HDC7379	73-79	13	25	25	PAPVC64
HDC8591	85-91	13	25	25	PAPVC75

**Description**  
Material: Stainless Steel

**WIRE CLIP WITH SCREW - IDEAL FOR LOADER HOSES WITH OUTER HELIX**



Part No.	Size range mm
3030200	33-37
3030218	35,5-40
3030226	38,5-43
3030234	41-46
3030242	43,5-49
3030250	46,5-53
3030269	50,5-56
3030277	53,5-60
3030285	56,5-64
3030293	60-68
3030306	64-72

**Description**  
 Wire: Steel wire B-UNI 3823  
 Screw: 6.6 grade steel Cr3 zinc-plated  
 This clip was specially designed for use with hoses incorporating an outer helix. It is generally used when installing ventilation ducting. The double-wire construction of this clip means that it sits comfortably on either side of the helix and can then be clamped down firmly thanks to the screw-tightening system.

# CAMLOCK COUPLINGS ALUMINIUM

## Camlock Couplings Aluminium

A range of Camlock couplings made according to A-A-59326, DIN 2828

Camlock is a safe coupling for use with hoses and pipes for many different media such as dry goods, polymer granules, cooling water, chemicals etc. The coupling connects easily by opening the wings, inserting the male part and then closing the wings by hand.

Body material :Aluminium A356 or A104

handle material: Brass

Sealing: NBR.

### HOSE TAIL LEVER COUPLING TYPE C

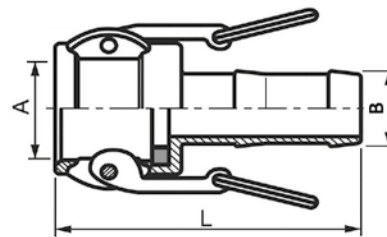

Part No.	Size	B	A	L	Max pressure
MPC-HC19	75	3/4"   19 mm.	32,4	91	17 bar
MPC-HC25	100	1"   25 mm.	37,2	105	17 bar
MPC-HC32	125	1.1/4"   32 mm.	46	112	17 bar
MPC-HC38	150	1.1/2"   38 mm.	53,9	118	17 bar
MPC-HC50	200	2"   50 mm.	63,7	135	17 Bar
MPC-HC64	250	2.1/2"   64 mm.	76,4	147	10 bar
MPC-HC75	300	3"   75 mm.	92,1	162	8 bar

### MALE THREADED LEVER COUPLING TYPE B

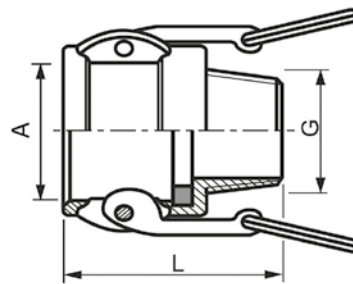

Part No.	Size	G	A	L	Max pressure
MPC-MC3/4	75	3/4"	32,4	47	17 bar
MPC-MC1	100	1"	37,2	56	17 bar
MPC-MC1-1/4	125	1.1/4"	46	64	17 bar
MPC-MC1-1/2	150	1.1/2"	53,9	66	17 bar
MPC-MC2	200	2"	63,7	76	17 Bar
MPC-MC2-1/2	250	2.1/2"	76,4	83	10 bar
MPC-MC3	300	3"	92,1	87	8 bar



**FEMALE THREADED LEVER COUPLING TYPE D**

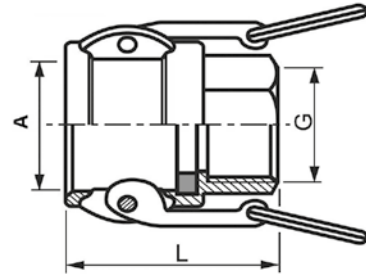

Part No.	Size	B	A	L	Max pressure
MPC-FC3/4	75	3/4"	32,4	47	17 bar
MPC-FC1	100	1"	37,2	56	17 bar
MPC-FC1-1/4	125	1.1/4"	46	64	17 bar
MPC-FC1-1/2	150	1.1/2"	53,9	67	17 bar
MPC-FC2	200	2"	63,7	76	17 Bar
MPC-FC2-1/2	250	2.1/2"	76,4	83	10 bar
MPC-FC3	300	3"	92,1	87	8 bar

**PIPE CONNECTION LEVER COUPLING TYPE D**

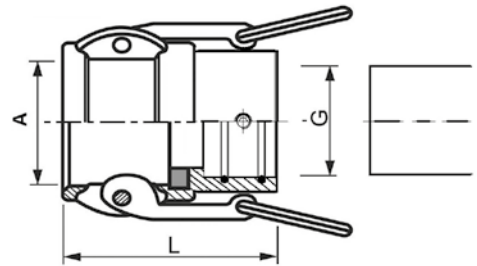

Part No.	Size	G	A	L	Max pressure
MPC-PC40	150	40	53,9	67	17 bar
MPC-FC45	200	45	63,7	76	17 Bar
MPC-FC50	200	50	63,7	76	17 Bar
MPC-FC60	250	60	76,4	83	10 bar

**DUST CAP LEVER COUPLING TYPE DC**

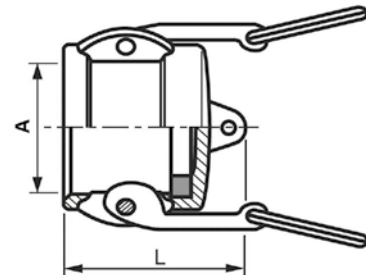

Part No.	Size	A	L	Max pressure
MPC-DC3/4	75	32,4	32	17 bar
MPC-DC1	100	37,2	40	17 bar
MPC-DC1-1/4	125	46	46	17 bar
MPC-DC1-1/2	150	53,9	48	17 bar
MPC-DC2	200	63,7	55	17 Bar
MPC-DC2-1/2	250	76,4	57	10 bar
MPC-DC3	300	92,1	59	8 bar

# CAMLOCK COUPLINGS ALUMINIUM

## GASKETS FOR CAMLOCK COUPLERS



Part No. NBR	Part No. Viton	Size	Dimension (mm)
G3/4 NBR	G3/4 FKM	3/4"	35 x 22 x 5.5
G1NBR	G1FKM	1"	40 x 27 x 6.4
G1-1/4NBR	G1-1/4FKM	1-1/4"	50 x 35 x 6.4
G1-1/2NBR	G1-1/2FKM	1-1/2"	56 x 41 x 6.4
G2NBR	G2FKM	2"	67 x 51 x 6.4
G2-1/2NBR	G2-1/2FKM	2-1/2"	80 x 64 x 6.4
G3NBR	G3FKM	3"	95 x 76 x 6.4

## HOSETAIL PLUG TYPE E

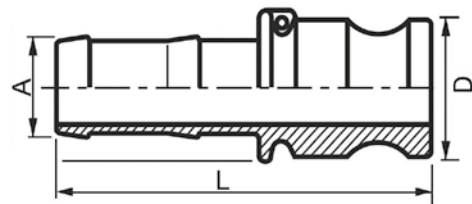

Part No.	Size	A	D	L	Max pressure
MPC-HP3/4	75	3/4"   19 mm.	32,1	86	17 bar
MPC-HP1	100	1"   25 mm.	36,7	103	17 bar
MPC-HP1-1/4	125	1.1/4"   32 mm.	45,5	107	17 bar
MPC-HP1-1/2	150	1.1/2"   38 mm.	53,4	114	17 bar
MPC-HP2	200	2"   50 mm.	63,1	131	17 Bar
MPC-HP2-1/2	250	2.1/2"   64 mm.	75,8	142	10 bar
MPC-HP3	300	3"   75 mm.	91,5	168	8 bar

## MALE THREADED PLUG TYPE F

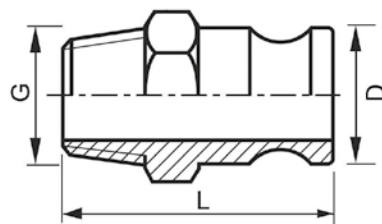

Part No.	Size	G	D	L	Max pressure
MPC-MP3/4	75	3/4"	32,1	55	17 bar
MPC-MP1	100	1"	36,7	67	17 bar
MPC-MP1-1/4	125	1.1/4"	45,5	74	17 bar
MPC-MP1-1/2	150	1.1/2"	53,4	76	17 bar
MPC-MP2	200	2"	63,1	87	17 Bar
MPC-MP2-1/2	250	2.1/2"	75,8	97	10 bar
MPC-MP3	300	3"	91,5	100	8 bar

**FEMALE THREADED PLUG TYPE A**

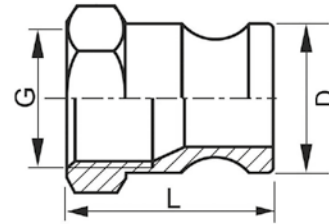

Part No.	Size	G	D	L	Max pressure
FPC-FP3/4	75	3/4"	32,1	40	17 bar
FPC-FP1	100	1"	36,7	48	17 bar
FPC-FP1-1/4	125	1.1/4"	45,5	54	17 bar
FPC-FP1-1/2	150	1.1/2"	53,4	56	17 bar
FPC-FP2	200	2"	63,1	63	17 Bar
FPC-FP2-1/2	250	2.1/2"	75,8	68	10 bar
FPC-FP3	300	3"	91,5	69	8 bar

**PIPE CONNECTION PLUG TYPE A**

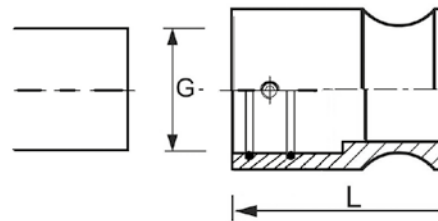

Part No.	Size	G	D	L	Max pressure
MPC-PP40	150	40	53,4	76	17 bar
MPC-PP45	200	45	63,1	87	17 Bar
MPC-PP50	200	50	63,1	87	17 Bar
MPC-PP60	250	60	75,8	97	10 bar

**DUST PLUG TYPE DP**

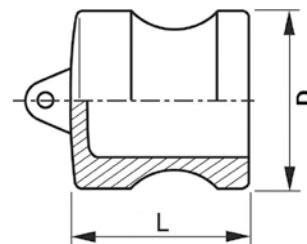

Part No.	Size	D	L	Max pressure
DPC-DP3/4	75	32,1	28	17 bar
DPC-DP1	100	36,7	35	17 bar
DPC-DP1-1/4	125	45,5	38	17 bar
DPC-DP1-1/2	150	53,4	40	17 bar
DPC-DP2	200	63,1	49	17 Bar
DPC-DP2-1/2	250	75,8	50	10 bar
DPC-DP3	300	91,5	51	8 bar

## VACUUM COUPLERS

### SUCTION COUPLINGS FOR MATERIAL CONVEYING OF STAINLESS STEEL 1.4305



**Description**

High quality quick coupling system for conveying of polymer granulates or liquids.

- Stainless Steel (wear resistance)
- Full flow passage
- Connections for pipes, tubes and hoses
- Quick and easy operation

### COUPLING FOR HOSE ATTACHMENT

STAINLESS  
STEEL



Part No.	Hose Attachment (mm)	Flow Ø	Diameter	Length	
VCH38	38	34	65	82	1
VCH40	40	36	65	82	1
VCH45	45	41	65	82	1
VCH50	50	41	65	82	1

### COUPLING FOR PIPE ATTACHMENT

STAINLESS  
STEEL

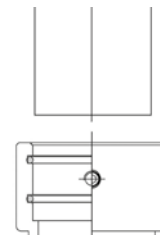

Part No.	Pipe Diameter (mm)	Flow Ø	Diameter	Length	
VCP38	38	34	65	68	1
VCP40	40	36	65	68	1
VCP45	45	41	65	68	1
VCP50	50	41	65	68	1

**COUPLING WITH FEMALE THREAD**

STAINLESS  
STEEL



Part No.	Thread	Flow Ø	Diameter	Length	
VCT1-1/2	1-1/2"	41	65	68	1
VCT2	2"	41	65	68	1

**BLIND COUPLING WITH CHAIN**

STAINLESS  
STEEL



Part No.	Diameter	Length	
VCB	65	82	1

**PLUG FOR HOSE ATTACHMENT**

STAINLESS  
STEEL





Part No.	Hose Attachment (mm)	Flow Ø	Diameter	Length	
VPH38	38	34	55	83	1
VPH40	40	36	55	83	1
VPH45	45	41	55	83	1
VPH50	50	41	55	83	1

## VACUUM COUPLERS

### PLUG FOR PIPE ATTACHMENT

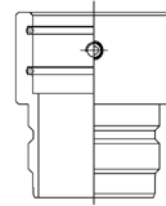
STAINLESS  
STEEL



Part No.	Pipe Diameter (mm)	Flow Ø	Diameter	Length	
VPP38	38	34	58	68,5	1
VPP40	40	36	58	68,5	1
VPP45	45	41	58	68,5	1
VPP50	50	41	58	68,5	1

### PLUG WITH FEMALE THREAD

STAINLESS  
STEEL



Part No.	Thread	Flow Ø	Diameter	Length	
VPT1-1/2	1-1/2"	41	59	65	1
VPT2	2"	41	59	65	1

### BLIND PLUG WITH CHAIN

STAINLESS  
STEEL



Part No.	Flow Ø	Diameter	Length	
VPB	-	58	60	1

**HOPPER MAGNETS**

STAINLESS  
STEEL



Part No.	Type	Strength (Gauss)	Size Diameter (mm)
D100	Standard	2500	100
D100-ES	Extra Strong	10000	100
D150	Standard	2500	150
D150-ES	Extra Strong	10000	150
D200	Standard	2500	200
D200-ES	Extra Strong	10000	200
D250	Standard	2500	250
D300	Standard	2500	300

**Description**

- Standard: Rare Earth
- Extra Strong: Neodymium
- Separation Magnets
- Stainless Steel encased
- Place direct in the Hopper to separate metal from polymers and avoid damage of nozzle and hotrunners etc.

**MATERIAL SCOOP**



Part No.	Size
2885	1.9ltr

**Description**

1.9Ltr Material Scoop  
Ideal for scooping granules and tipping into material hoppers

# BALANCES AND MOISTURE ANALYSER

## COMPACT BALANCE



Part No.	Capacity	Readability	Platform Size
MCB500	500 g	0,1 g	Ø 120 mm
MCB2000	2000 g	0,1 g	Ø 120 mm

### Description

Compact balance for weighing parts up to 2000 g

### Features:

Backlit LCD display  
 Stainless steel pan  
 ShockProtect™ overload three-point protection  
 Can be stacked for storage  
 Lock down mounting slot for Kensington™ type lock and cable  
 Dual tare keys  
 Lightweight and portable  
 Colour coded, sealed keypad

Modern low profile design  
 Low cost and simple to use  
 External calibration  
 Auto sleep / power down function to save battery life  
 Auto power off  
 Low battery indication  
 AC Adaptor

### Applications:

Weighing  
 Percentage weighing  
 Parts counting  
 Below balance weighing  
 Weight accumulation

## PRECISION BALANCE



Part No.	Capacity	Readability	Platform Size
MPB410	410 g	0,001 g	Ø 120 mm

### Description

Precision Balance for weighing parts with very accurate tolerance.

### Features:

Backlit LCD display  
 Colour coded keys  
 Level indicator with adjustable levelling feet  
 Removable draft shield supplied  
 Robust metal housing

Sealed keypad  
 External calibration  
 Pan lifter to easily remove samples

### Applications:

Weighing  
 Net / Total  
 Check weighing  
 Percentage weighing  
 Weight accumulation

Parts counting  
 Animal / dynamic weighing  
 Density determination  
 Below balance weighing

## DISPOSABLE SAMPLE PANS



Part No.	Deep (mm)	
MMB-P50	10 mm	50

### Description

Aluminum sample pans are ideal for moisture analysis testing. The disposable pans fit neatly on the MMB moisture analysers pan holder. They are 10mm deep to keep the items being weighed in place. This pack holds 50 disposable pans.



**MOISTURE ANALYSER**



Part No.	Capacity	Readability	Platform Size
MMB65	65 g	0,001 g	Ø 100 mm

**Description**

The MMB Moisture Analyser makes moisture analysis of plastic granules easy for fast and accurate results. The moisture analyzer comprises of a balance and an integrated heater. The analyser will first weigh the material sample in a foil tray at the start of the process; it will then heat the sample up, removing the moisture, and continue heating sample until it stops losing weight. This data is then used to calculate the moisture content based on the moisture loss rate, known as a drying curve.

**Features:**

- USB port for memory card and USB I/O interface
- RS-232 interface
- Built-in memories for storing products and settings
- 3 settings for heating sample, ramp up, step and standard
- Automatic test start setting for when the lid is closed
- Pan lifter to easily remove samples
- Large backlit display with dual text prompts

**CALIBRATION WEIGHTS**



Part No.	Weight
CALW20G	20 g
CALW50G	50 g
CALW200G	200 g
CALW1000G	1000 g

**Description**

Ideal for calibrating Scales and moisture analyser.

**THERMAL PRINTER**



Part No.	Power Supply	Paper Width
ATP-100	110/230 VAC - 8,5 VDC	57,5

**Description**

Mouldpro's ATP thermal printer is compact and ideally suited for use with balances and scales. Simple-to-use features combined with quick set-up makes for a truly versatile printer.

**Features:**

- A single positive push-button feed key and three easy-to-read LED indicators make operation simple.
- Combined with the compact design, which takes little space on the bench, this makes the ATP the right choice for any printing applications.

**Spare Paper:**

- No. ATP-100-1 Thermal paper
- No. ATP-100-10 Thermal paper (10pk)

# 06.

## END OF ARM TOOLING

**139**

06.1 QUICK CHANGE

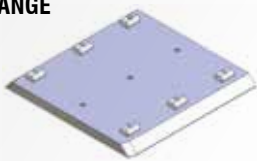

**141**

06.2 FRAMES



**142**

06.3 FRAME CONNECTORS



**145**

06.4 MOUNTING CLAMPS

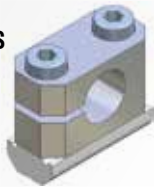

**152**

06.5 VACUUM CUP ADAPTORS



**156**

06.6 VACUUM CUPS



**160**

06.7 PNEUMATIC GRIPPERS



**167**

06.8 PNEUMATIC GATE CUTTERS



**170**

06.9 PNEUMATIC PUSH-IN FITTING



**QUICK CHANGE PLATES "GRIPPER SIDE"**

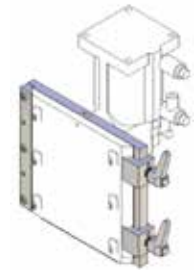
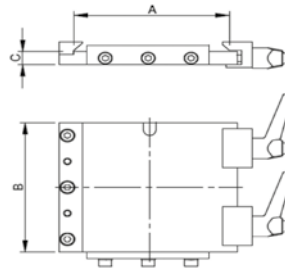
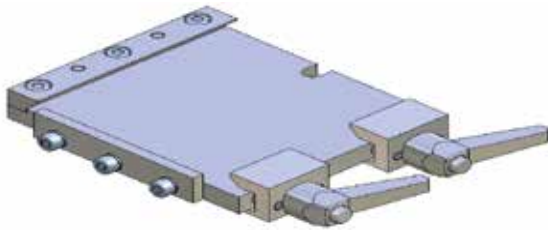

Part No.	A	B	C	Max load	Reference	Weight
QC-RSW-60-00	60	60	10	5 kg	QC-SSW-60	140 g
QC-RSW-100-00	100	100	10	10 kg	QC-SSW-100	442 g
QC-RSW-160-00	160	160	10	20 kg	QC-SSW-160	1132 g
QC-RSW-250-00	250	250	10	40 kg	QC-SSW-250	2963 g

**Description**  
 Material: Aluminium  
 Surface silver anodized

**PNEUMATIC MANIFOLD CONNECTION**

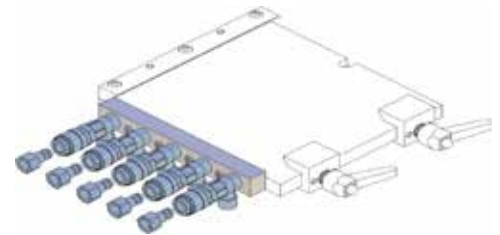
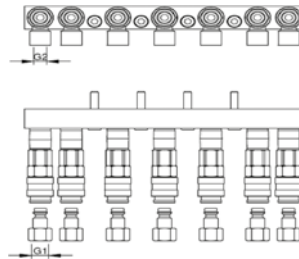

Part No.	G1	G2	No. of Connections	Reference	Weight
CA.LAL.1.5	M5	M5	5	QC-RSW-100	154 g
CA.LAL.1.7	M5	M5	7	QC-RSW-100	225 g
CA.LAL.2.5	G 1/8	G1/8	5	QC-RSW-160	631 g
CA.LAL.2.7	G 1/8	G 1/8	7	QC-RSW-160	742 g
CA.LAL.3.6	G 1/4	G 1/4	6	QC-RSW-250	902 g
CA.LAL.3.8	G 1/4	G 1/4	8	QC-RSW-250	1504 g

**Description**  
 Couplers are Standard "Rectus 21" series

**QUICK CHANGE PLATES "GRIPPER SIDE"**

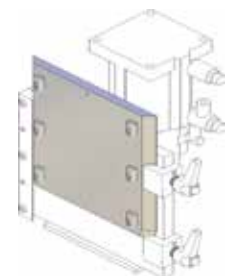
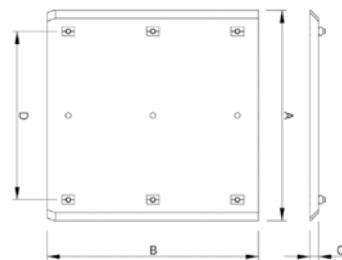
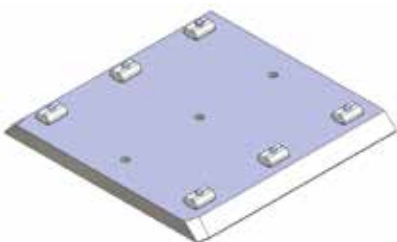

Part No.	A	B	C	D	Weight
QC-SSW-60	60	60	8	35	93 g
QC-SSW-100	100	100	8	70	242 g
QC-SSW-160	160	160	10	120	695 g
QC-SSW-250	250	250	10	200	1641 g

**Description**  
 Material: Aluminium  
 Surface silver anodized

# QUICK CHANGERS

## QUICK CHANGER ROBOT SIDE

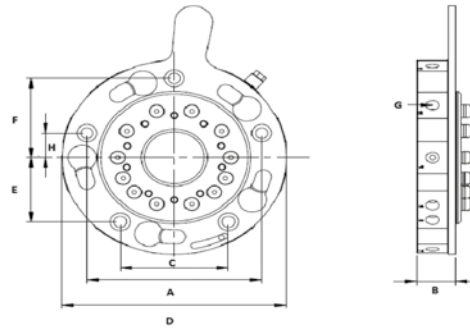
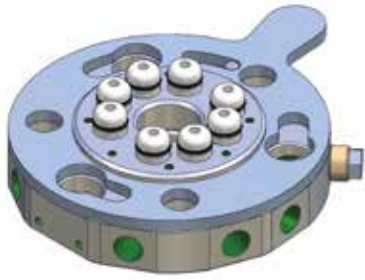

Part No.	D	A	C	E	F	H	G	B	Weight
MRS-90	90	-	53,6	22,5	35	-	G1/8 (8x)	18,3	318 g.
MRS-150	150	116,03	71,7	49,35	61	18,85	G1/4 (10x)	25,95	1123 g.
MRS-160	160	116,03	71,7	49,35	61	18,85	G1/8 (12X)	25,95	1200 g.

**Description**

- Quick changer for easy replacement of EOAT on the robot
- Suitable for vacuum connectors as well
- Avoids mistakes in pneumatic/electrical connections
- Available with 8 ,10 or 12 pneumatic interface
- 15 pins D-SUB electrical interface
- Robot side and Gripper side part are supplied separately

## QUICK CHANGER GRIPPER SIDE

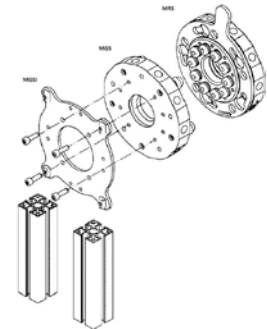
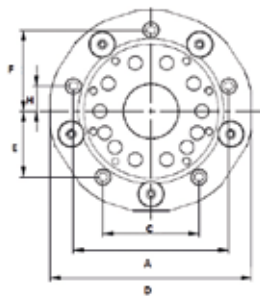

Part No.	D	A	C	E	F	H	G	B	Weight
MGS-90	90	-	-	-	-	-	G1/8 (8x)	15,9	227 g.
MGS-150	150	114,13	70,53	48,54	60	18,54	G1/4 (10x)	21,2	827 g.
MGS-160	160	114,13	70,53	48,54	60	18,54	G1/8 (12X)	21,2	900 g.

## INTERFACE FOR QUICK CHANGE

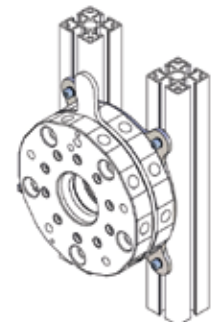
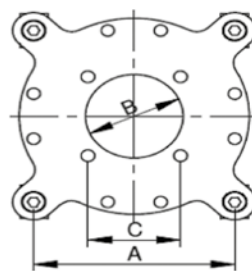

Part No.	A	B	C	D	Reference	Weight
MGSI-90	76	37	35	3	MGS-90	174 g
MGSI-150	110	70	52	4	MSG-150/MSG-160	502 g

**PROFILES**

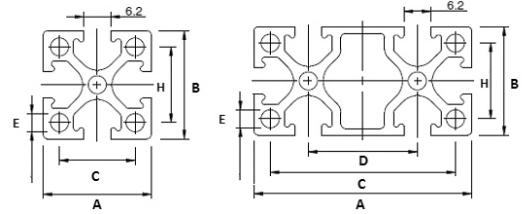
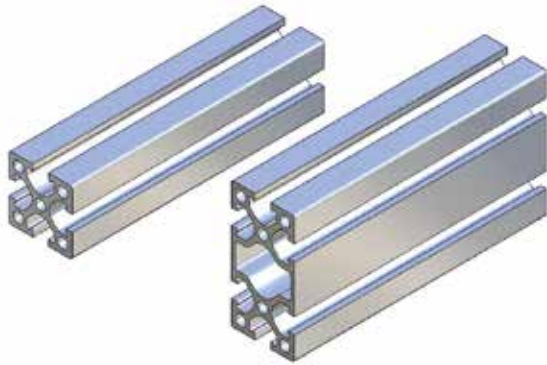

Part No.	A	B	C	D	E	H	Length
APX25-25-1000	25	25	17,5	-	4,2	17,5	1000
APX25-50-1000	25	50	42,5	25	4,2	17,5	1000
APL40-40-1000	40	40	32	-	5	32	1000
APL40-80-1000	40	80	72	40	5	32	1000

**Description**  
 Material: Aluminium  
 Surface silver anodized

**CAP FOR PROFILE**

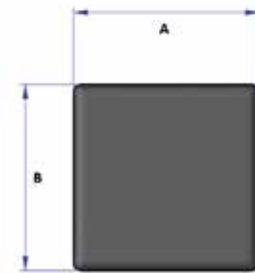

Part No.	A	B	
MPP-25-25	25	25	10
MPP-25-50	25	50	10
MPP-40-40	40	40	10
MPP-40-80	40	80	10

**CORNER CONNECTOR**

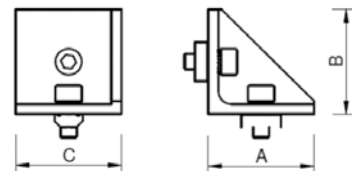

Part No.	A	B	C	Profile
MPWIV.X.25.0	25	25	16	X
MPWIV.X.50.25	51	51	16	X
MPWIV.L.40	40	40	40	L
MPWIV.L.40.E	38	38	38	L

## FRAME CONNECTORS

### NUTS FOR PROFILE

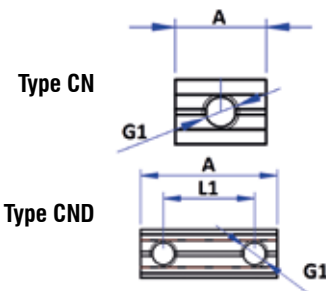
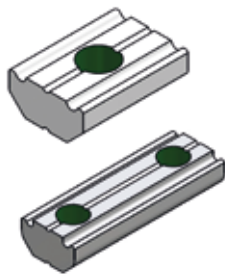

Part No.	G1	A	L1
CN-M3	M3	15	
CN-M4	M4	15	
CN-M5	M5	15	
CN-M6	M6	15	
CND-M4	M4	24	16
CND-M5	M5	30	20
CND-M6	M6	30	20

### PROFILE CONNECTOR - STRAIGHT

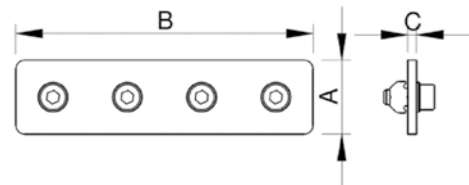
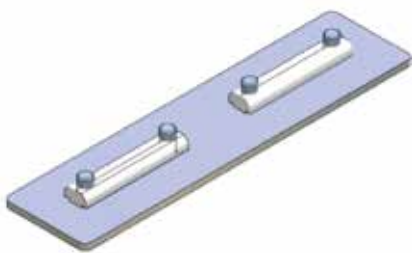

Part No.	A	B	C	Profile
MPVBG.X.25.50	25	50	3	X
MPVBG.X.50.50	50	50	3	X
MPVBG.L.40.80	40	80	3	L

### PROFILE CONNECTOR L-STYLE

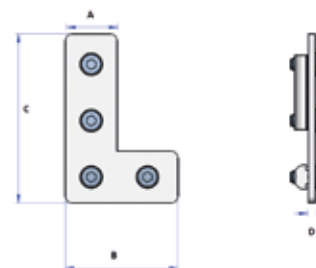
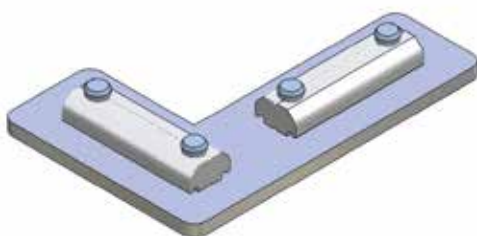

Part No.	A	B	C	D
MA.VBL.50.50	25	50	50	3
MA.VBL.50.75	25	50	75	3
MA.VBL.80.80	40	80	80	3
MA.VBL.80.120	40	80	120	3

**PROFILE CONNECTOR T-STYLE**

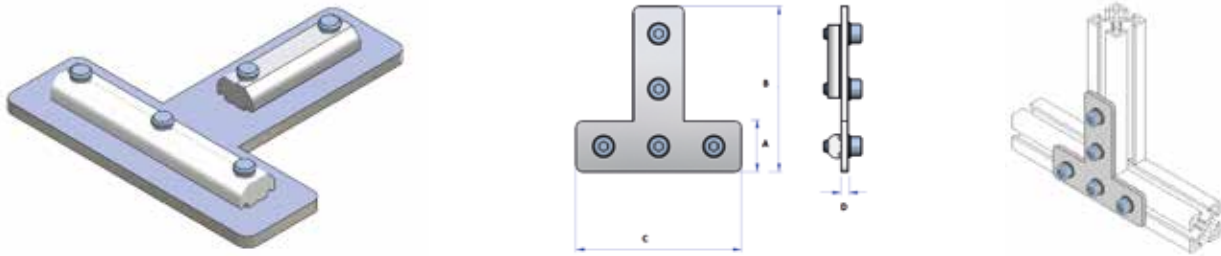

Part No.	A	B	C	D
MA.VBT.50.75	25	50	75	3
MA.VBT.75.100	25	75	100	3
MA.VBT.120.80	40	120	80	3

**ADJUSTABLE CONNECTOR 0-90 DEGREE**



Part No.	A	B	C	Profile
MPVBW.X.0.90	50	70	3	X
MPVBW.L.0.90	80	120	3	L

**END PLATE FOR PROFILE**

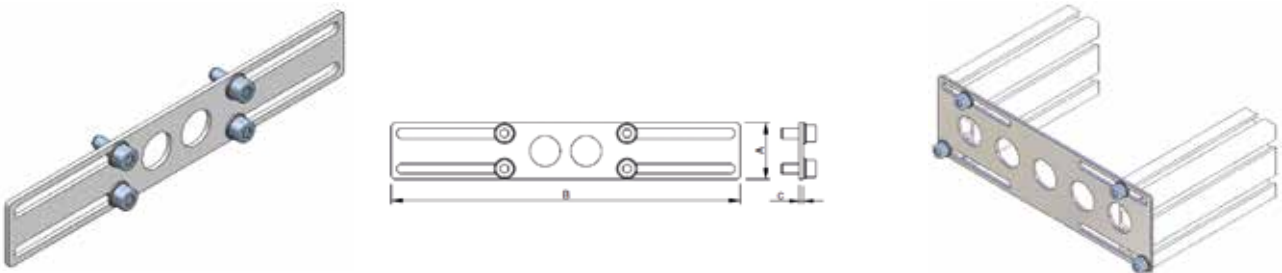

Part No.	A	B	C	Reference	Weight
EP25.170	25	170	2	APX25-25..	48 g
EP25.220	25	220	2	APX25-25..	60 g
EP25.270	25	270	2	APX25-25..	69 g
EP25.320	25	320	2	APX25-25..	85 g
EP50.25.170	50	170	2	APX25-50..	100 g
EP50.25.220	50	220	2	APX25-50..	130 g
EP50.25.270	50	270	2	APX25-50..	162 g
EP50.25.320	50	320	2	APX25-50..	192 g

**Description**  
Material: Steel

# FRAME CONNECTORS

## PROFILE END CONNECTOR

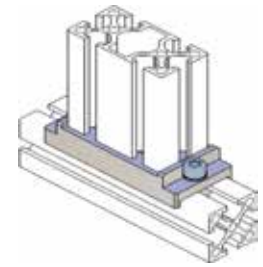
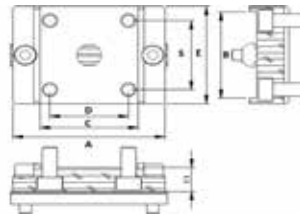
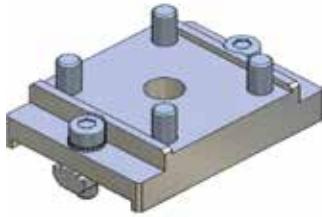

Part No.	A	B	C	D	E	Reference	Weight
PE.25.25	50	25	25	17,5	17,5	APX25-25..	69 g
PE.25.50	70	25	50	42,5	17,5	APX25-50..	87 g
PE.40.40	62	40	40	32	32	APX40-40..	128 g

**Description**  
 Material: Aluminium  
 Surface silver anodized

## PROFILE END CONNECTOR DOUBLE

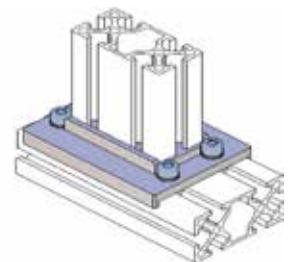
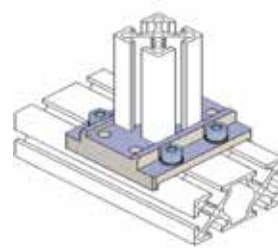
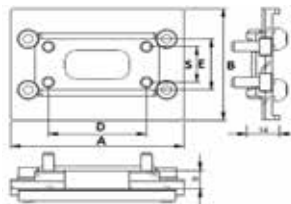
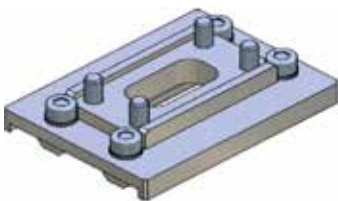

Part No.	A	B	D	E	Reference	Weight
PED.25.50	55	50	17,5	17,5	APX25-25../APX25-50	69 g
PED.50.50	75	55	42,5	17,5	APX25-50/APX25-50..	87 g

**Description**  
 Material: Aluminium  
 Surface silver anodized

## CROSS CONNECTOR BRIDGE

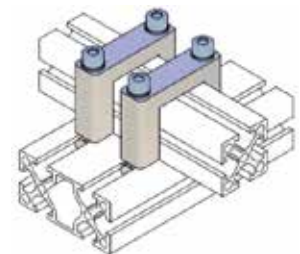
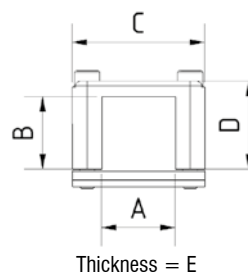

Part No.	A	B	C	D	E	Profile
CCB25-25-X	25	25	45	30	15	X
CCB50-25-X	50	25	45	55	15	X
CCB25-50-X	25	50	70	30	15	X
CCB40-40-L	40	40	60	48,5	15	L
CCB80-40-L	80	40	100	50	15	L

**Description**

- Cross connecting bridges for
- Connecting of two sections
- It does not have to be drilled
- Secure connection between two profiles



**LONG ANGLE CLAMP - SWIVEL HEAD**

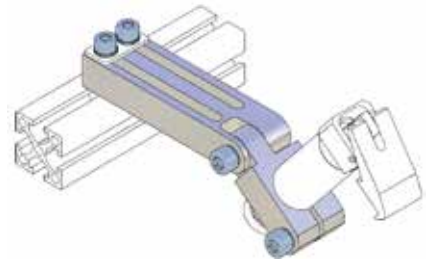
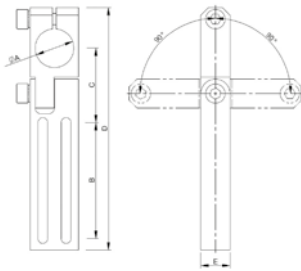
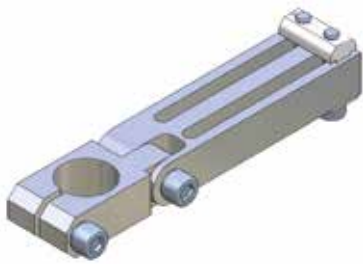

Part No.	A	B	C	D	E	Reference	Weight
LA.GA.10.X	10	40	26,6	85,3	10	APX25..	57 g
LA.GA.14.X	14	40	27,8	88,3	10	APX25..	57 g
LA.GA.20.X	20	60	38,5	125,5	15	APX25../APL40..	122 g
LA.GA.30.X	30	82	53	168,5	20	APL40..	266 g

**Description**  
 Material: Aluminium  
 Surface silver anodized

**CROSS CONNECTOR**

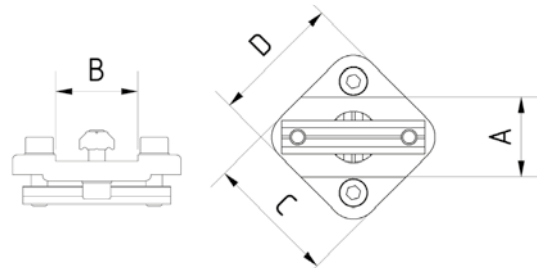
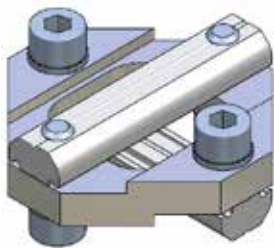

Part No.	A	B	C	D	Profile
CC25-25-X	25	25	41	41	X
CC50-25-X	50	25	70	50	X
CC50-50-X	50	50	70	70	X
CC40-40-L	40	40	60	60	L
CC80-40-L	80	40	100	60	L
CC80-80-L	80	80	100	100	L
CC40-25-L	40	25	70	41	L

**Description**

- Cross connecting plates for connecting of two sections diagonally
- It does not have to be drilled
- Secure connection between two profiles
- Ideal connectivity through guide

# MOUNTING CLAMPS

## MOUNTING BRACKET

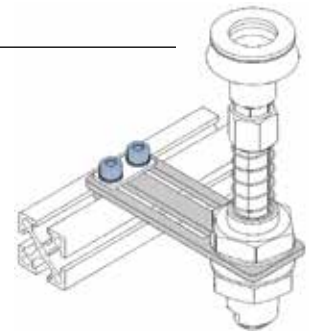
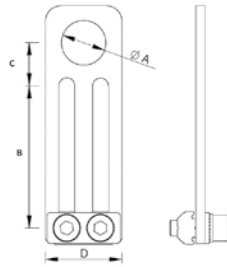
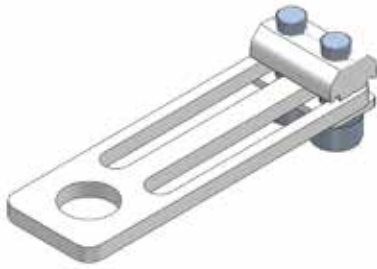

Part No.	A	B	C	D	Weight
MB.04.20.10.X	10	40	11	20	35 g
MB.04.20.14.X	14	46	14	25	45 g
MB.04.02.20.X	20	51,5	19	30	65 g
LA.GA.30.X	30	82	53	168,5	266 g

**Description**  
 Material: Aluminium  
 Surface silver anodized

## ADJUSTABLE CLAMP

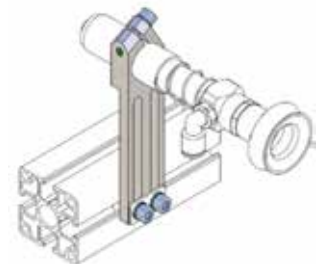
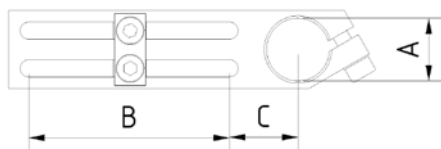
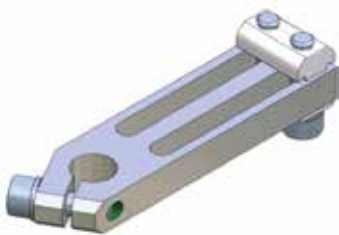

Part No.	A	B	C	Profile
AC10-40-X	10	40	24	X
AC14-40-X	14	40	19	X
AC20-60-X	20	60	22	X
AC20-70-L	20	70	25	L
AC30-70-L	30	70	27	L

**Description**

- Adjustable clamp - strong version
- The clamping of components
- The device can be mounted in very close range.
- Perfect accessibility of individual screws

## ROUND CLAMP

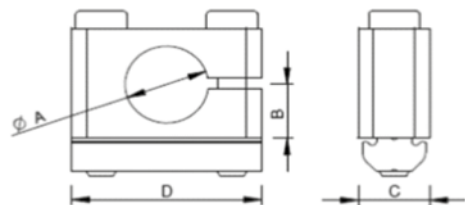
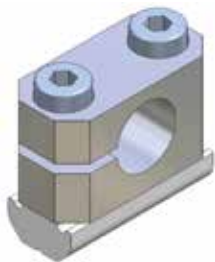

Part No.	A	B	C	D
RC10	10	8	12	15
RC14	14	10	12	32
RC20	20	13	12	40
RC30	30	18	20	52

**Description**

- Very robust and accurately fitting construction
- The inside threads are formed
- All edges are rounded

**CROSS CONNECTOR**

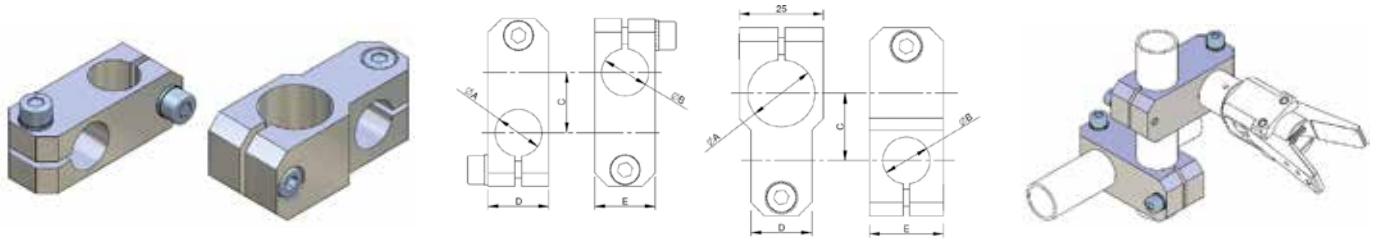

Part No.	A	B	C	D	E	Weight
CCT.10.10	10	10	16	14	14	17 g
CCT.14.14	14	14	18	18	18	35 g
CCT.20.20	20	20	26	25	25	71 g
CCT.20.10	20	10	20	14	20	41 g
CCT.20.14	20	14	20	18	22	48 g

**Description**  
 Material: Aluminium  
 Surface silver anodized

**CROSS CONNECTOR WITH BALL JOINT**

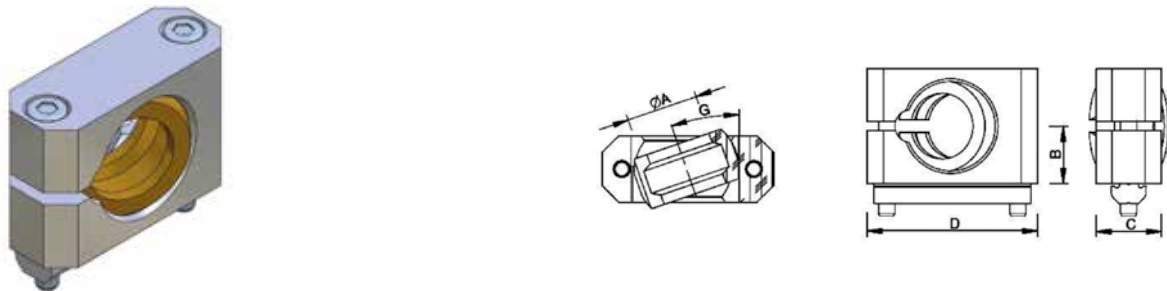

Part No.	A	B	C	D	G	Profile
MPKVB.KG.X10	10	10	12	32	0-13°	X
MPKVB.KG.X14	14	12,5	15	40	0-17°	X
MPKVB.KG.L20	20	17,5	20	52	0-19°	L

**ANGLE CLAMP**

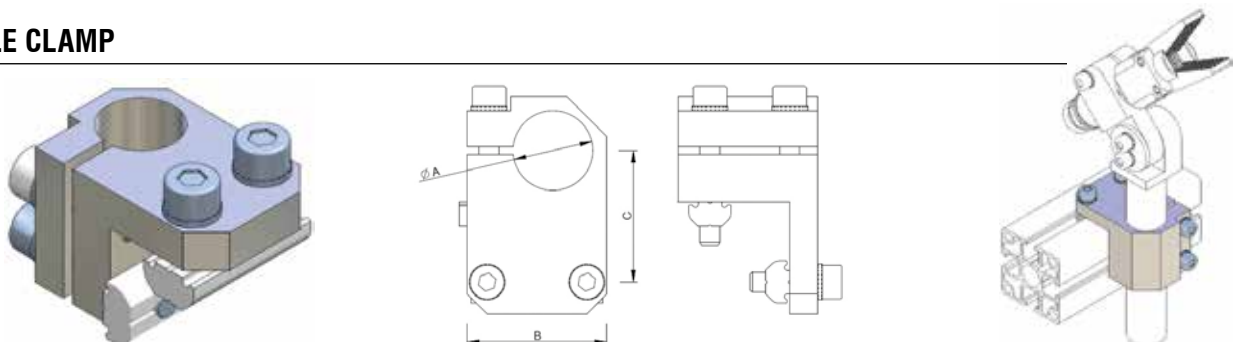

Part No.	A	B	C	Weight
CA.10.X	10	25	19,5	57 g
CA.14.X	14	25	21,5	60 g
CA.20.X	20	32	24,5	80 g
CA.20.JU	20	35	33	105 g
CA.30.JU	30	45	39	178 g

**Description**  
 Material: Aluminium  
 Surface silver anodized

# MOUNTING CLAMPS

## PARALLEL CLAMP

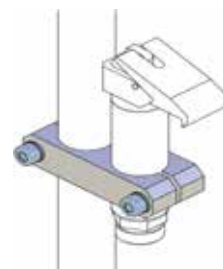
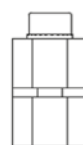
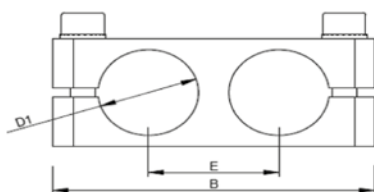
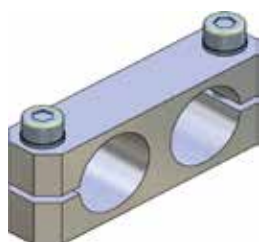

Part No.	D1	B	E	Weight
CA.1010.15	10	38	15	12 g
CA.1414.20	14	52	20	27 g
CA.2020.26	20	64	26	47 g
CA.3030.38	30	88	38	104 g

**Description**

Material: Aluminium  
Surface silver anodized

## ELBOW GRIPPER ARM - ADJUSTABLE

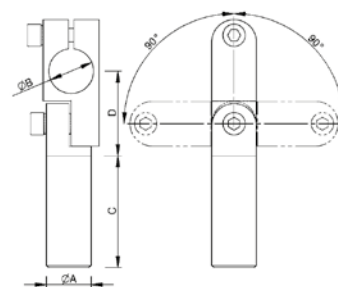

Part No.	A	B	C	D
MA.GLA.1010.90	10	10	90	22
MA.GLA.1414.120	14	14	120	30
MA.GLA.2020.150	20	20	150	38

## ANGLE GRIPPER ARM - EXTENDED

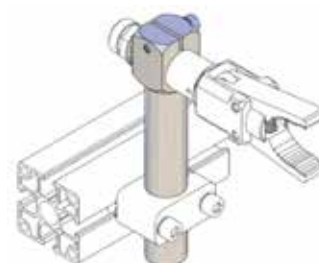
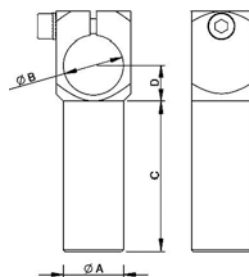

Part No.	A	B	C	D
MA.WKA.1010.90	10	10	90	8
MA.WKA.1414.120	14	14	120	10
MA.WKA.2020.150	20	20	150	12

**EXTENSION TUBE**

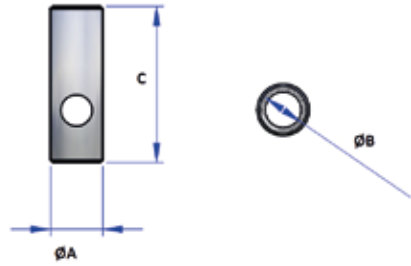

Part No.	A	B	C
MA.VLR.10.90	10	M8X1	90
MA.VLR.14.120	14	M12X1	120
MA.VLR.20.150	20	M17X1	150

**CENTERING PIN**

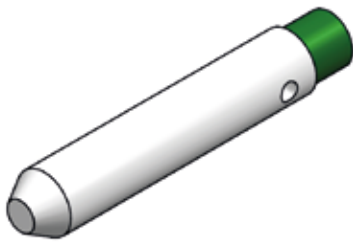

Part No.	A	B	C
MA.ZTB.1060	10	M8X1	60
MA.ZTB.1480	14	M12X1	80
MA.ZTB.20100	20	M17X1	100

## MOUNTING CLAMPS

### VACUUM CUP ADAPTOR

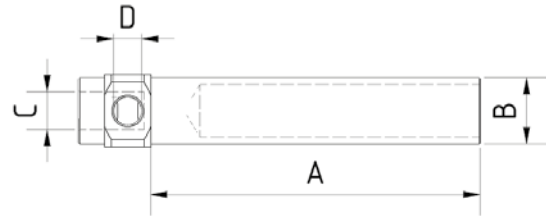

Part No.	A	B	C	D
VCAF10-60-M5-M5	60	10	M5	M5
VCAF14-80-G1/8-G1/8	80	14	G1/8	G1/8
VCAF20-100-G1/8-G1/8	100	20	G1/8	G1/8
VCAF20-150-G1/8-G1/4	150	20	G1/4	G1/8

**Description**

- Used for the optimum positioning of a vacuum cup
- Extremely flexible when positioning the vacuum suction cup

### SWIVEL VACUUM CUP ADAPTOR

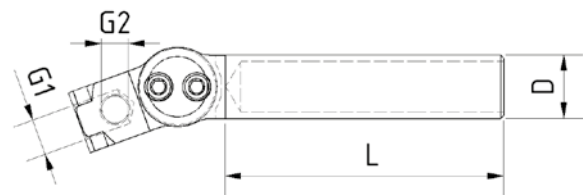
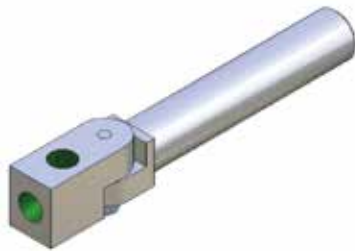

Part No.	D	L	G1	G2
VCAS10-60-M5-M5	10	60	M5	M5
VCAS14-80-G1/8-G1/8	14	80	G1/8	G1/8
VCAS20-100-G1/4-G1/8	20	100	G1/4	G1/8
VCAS20-150-G1/4-G1/8	20	150	G1/4	G1/8

**Description**

- To optimise position and angle of a vacuum cup
- Very robust and accurate fitting construction
- Safe and stable mounting of the angle by two screws

### VACUUM ADAPTOR FOR PROFILES

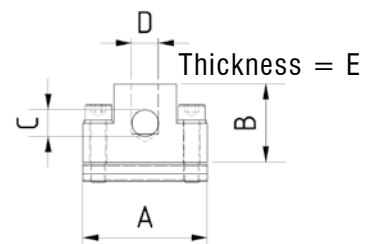
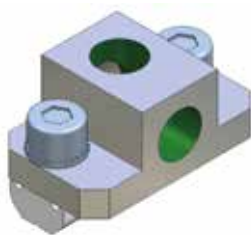

Part No.	A	B	C	D	E	Profile
VCAP-G1/8-G1/8-X	40	25	G1/8	G1/8	20	X
VCAP-G1/4-G1/4-X	40	25	G1/4	G1/4	20	X

**Description**

- For the direct connection of a vacuum cup
- Compact design

**THREAD CLAMP FIXED**

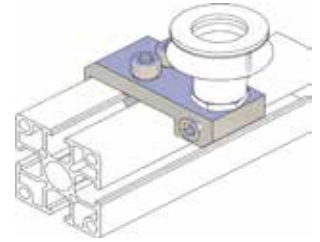
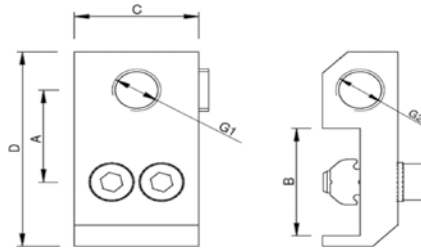
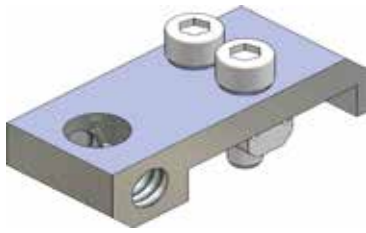

Part No.	A	B	C	D	G1	G2	Weight
TC.X.18.18	22	25	25	46	G 1/8	G 1/8	49 g
TC.X.14.18	22	25	25	46	G 1/4	G 1/8	49 g
TC.JU.14.18	29	40	25	60	G 1/4	G 1/8	49 g

**Description**  
 Material: Aluminium  
 Surface silver anodized

**ADJUSTABLE CLAMP**

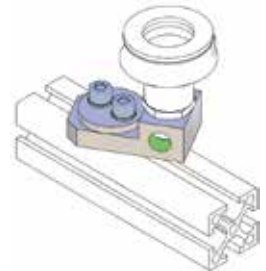
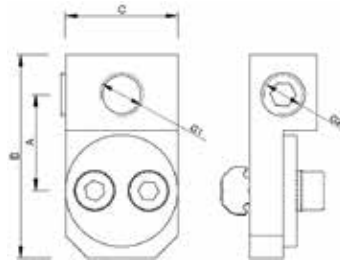
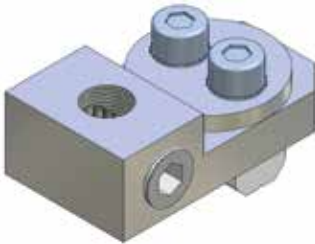

Part No.	A	B	C	G1	G2	Profile	Weight
CA.WSD.X.18.18	21	46	25	G 1/8	G 1/8	X	44 g
CA.WSD.X.14.18	21	46	25	G 1/4	G 1/8	X	44 g

**Description**  
 Material: Aluminium  
 Surface silver anodized

## VACUUM CUP ADAPTORS

### SPRING LOADED LEVEL COMPENSATOR - NON ROTATIONAL - THREADED BODY

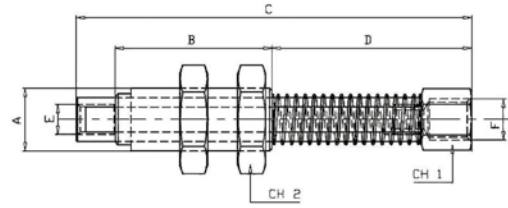

Part No.	A	B	C	D	E	F	CH1	CH2	Stroke Hub (mm)
LC.M10.20	M10x1.25	26	71	42	M5	M5	13	14	20
LC.M12.20	M12x1.25	26	61	32	M5	1/8"	10	17	20
LC.M14.38	M14x1.5	30	94	61	M5	1/8"	13	19	38
LC.M20.48	M20x1.5	50	126	73	1/8"	1/4"	17	27	48

**Description**

Spring: Steel  
 Sliding Parts: Chrome-plated Brass  
 Terminal Parts: Anodized Aluminium

### SPRING LOADED LEVEL COMPENSATOR - NON ROTATIONAL - SMOOTH BODY

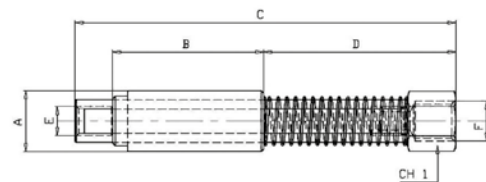

Part No.	A	B	C	D	E	F	CH1	Stroke Hub (mm)
LC.10.20	ø10	26	71	42	M5	M5	13	20
LC.12.20	ø12	26	71	42	M5	M5	13	20
LC.14.38	ø16	30	94	61	M5	1/8"	13	38
LC.20.48	ø20	50	126	73	1/8"	1/4"	17	48

**Description**

Spring: Steel  
 Sliding Parts: Chrome-plated Brass  
 Terminal Parts: Anodized Aluminium



**SPRING LOADED LEVEL COMPENSATOR - SMOOTH BODY**

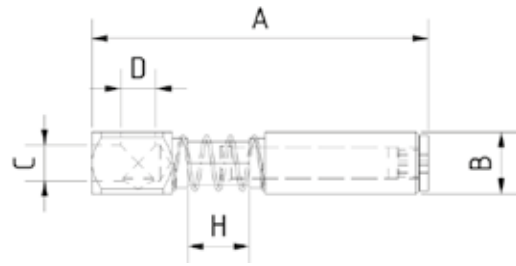

Part No.	A	B	C	D	H
VCASL10-76-H20-M5-M5	76	10	M5	M5	20
VCASL14-80-H15-G1/8-G1/8	80	14	G1/8	G1/8	15
VCASL14-105-H35-G1/8-G1/8	105	14	G1/8	G1/8	35
VCASL20-115-H20-G1/4-G1/4	115	20	G1/4	G1/4	20
VCASL20-139-H40-G1/4-G1/4	139	20	G1/4	G1/4	40

**Description**

- Non-Rotational
- Compensates the differential movement during the removal from the mould
- Fixed Head
- The component is hard anodized and has excellent gliding properties

**SPRING LOADED LEVEL COMPENSATOR - THREADED BODY**

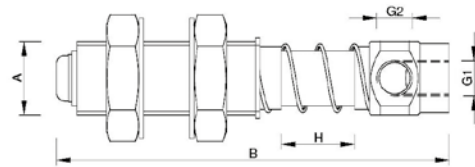
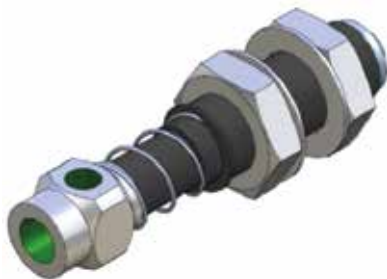

Part No.	A	B	G1	G2	H
MA.GGDG.10050510	M10X1	59	M5	M5	10
MA.GGDG.10050530	M10X1	85	M5	M5	30
MA.GGDG.14181815	M14X1,5	86	G1/8	G1/8	15
MA.GGDG.14181840	M14X1,5	111	G1/8	G1/8	40
MA.GGDG.20141820	M20X1,5	109	G1/8	G1/8	20
MA.GGDG.20141850	M20X1,5	147	G1/8	G1/8	50

**Description**

- Non-Rotational
- Compensates the differential movement during the removal from the mould
- Fixed Head
- The component is hard anodized and has excellent gliding properties

## VACUUM CUP ADAPTORS

### ELBOW - ADJUSTABLE

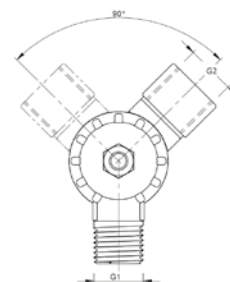

Part No.	G1	G2
MP07.01.001	1/8	1/8
MP07.01.002	1/4	1/4

### SMOOTH BODY NON-ROTATIONAL TELESCOPIC LEVEL COMPENSATOR

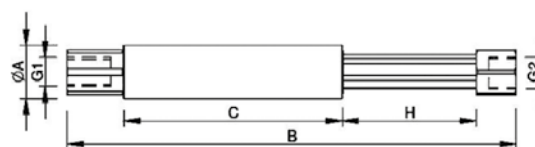

Part No.	A	B	C	G1	G2	H
MPSDN.1010	10	60,5	26,5	M5	M5	10
MPSDN.1025	10	59,5	41,5	M5	M5	25
MPSDN.1420	14	102,5	42	G1/8	G1/8	20
MPSDN.1435	14	132,5	60	G1/8	G1/8	35
MPSDN.2025	20	114,5	55	G1/8	G1/8	25
MPSDN.2050	20	169	82,5	G1/8	G1/8	50

### THREADED BODY NON-ROTATIONAL TELESCOPIC LEVEL COMPENSATOR

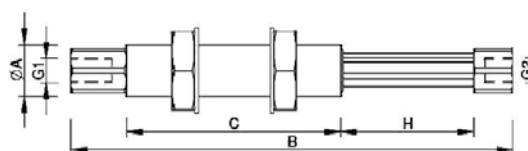

Part No.	A	B	C	G1	G2	H
MPSDNG.1010	M10X1	60,5	26,5	M5	M5	10
MPSDNG.1025	M10X1	59,5	41,5	M5	M5	25
MPSDNG.1420	M14X1,5	102,5	42	G1/8	G1/8	20
MPSDNG.1435	M14X1,5	132,5	60	G1/8	G1/8	35
MPSDNG.2025	M20X1,5	114,5	55	G1/8	G1/8	25
MPSDNG.2050	M20X1,5	169	82,5	G1/8	G1/8	50

**TYPE SELECTION GUIDE**

**Type**

**Flat Cups**

The flat suction cups provide accuracy in load gripping and speeds up the cycle process. Flat cups are used only on flat surfaces.



**1,5 Bellow Cups**

The 1,5 bellow cups combine the advantages of the flat suction cups (precision and positioning) with the freedom of bellows (angle and flexibility). They provide flexibility, precision and low internal volume suitable for high-speed applications.



**2,5 Bellow Cups**

The suction cups with 2,5 bellow are recommended for gripping products with un-even surfaces (large deflection).  
The 2,5 bellow allow objects to be gripped from an angle (ball-joint effect).



**MATERIAL PROPERTIES**

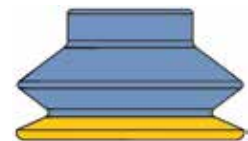
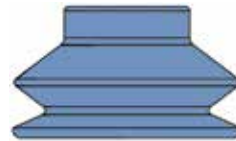
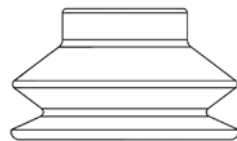

Application	Silicone	FlexTemp HT	Multiflex
Ozone resistance	✓✓✓	✓✓	✓✓✓
Oil resistance	✓	✓✓✓	✓✓
Wear resistance	✓✓	✓✓	✓✓✓
Tensile strength (lifting force)	✓	✓	✓✓✓
Leaves marks on products	✓	✓✓	✓✓✓
Temperature resistance	-70 to + 200°C	-40 to + 160°C	-20 to + 80°C
Shore hardness	30-60°	30-60°	60°

**Description**

The holding force of the suction cups increases proportionally with the difference between the ambient pressure and the pressure inside the cup.

The holding force of a suction pad is calculated with the formula:

$$F = \Delta p \times A$$

F = Holding force

$\Delta p$  = Difference between ambient pressure and pressure of the system

A = Effective suction area (the effective area of a suction pad under vacuum)

This means the holding force is proportional to the pressure difference and the suction area. The greater the difference between ambient pressure and pressure in the suction cup or the larger the effective suction area, the greater the holding force.

The force can vary depending on a change of the pressure difference and area parameters.

# VACUUM CUPS

## FLAT VACUUM CUPS Ø 22 - 53 MM

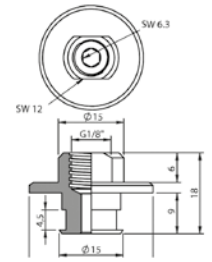
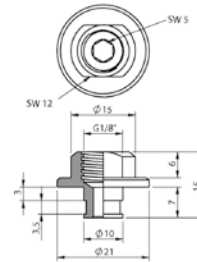
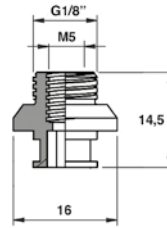
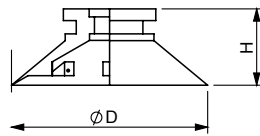

Part No. Silicone	Part No. TempFlex HT		ØD	H	Retaining Ring No.	Part No.	Part No.	Part No.
F20S	F20HT	0,5	22	8	R.011	F250		
F25S	F25HT	1	28	9	R.011	F250		
F30S	F30HT	1,5	32	10	R.011	F250		
F40S	F40HT	2	42	13	R.012		F251	
F50S	F50HT	3	53	17,5	R.013			F252

## BELLOW VACUUM CUPS - 1,5 BELLOW, Ø 11 AND Ø 16 MM

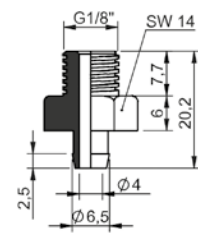
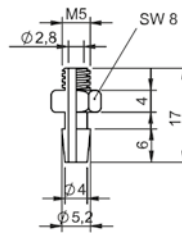
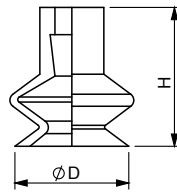

Part No. Silicone	Part No. TempFlex HT		ØD	H	Part No.	Part No.
B11S	B11HT	5	11	17	F134	130.003
B16S	B16HT	7	16	19	F134	130.003

## BELLOW VACUUM CUPS - 1,5 BELLOW, Ø20-Ø52



Vacuum Cup						Fitting					Retaining Ring			

Part No. Silicone	Part No. TempFlex HT		ØD	Ø D1	H	Part No.	ØA	B	C	E	Part No.	ØN	ØO	P
B20S	B20HT	9 mm	21,5	24	20	F250	16	14,5	M5	G1/8"	R.011	14	9,7	1,8
B30S	B30HT	9 mm	33	36	26	F250	16	14,5	M5	G1/8"	R.011	14	9,7	1,8
B40S	B40HT	9 mm	42	46	28	F251	21	15	G1/8"	Ø15	R.012	20	13	2,5
B50S	B50HT	12 mm	52	58	35	F252	28	18	G1/8"	Ø15	R.013	26	19	3,2

**BELLOW VACUUM CUPS - 1,5 BELLOW, Ø11-Ø25**

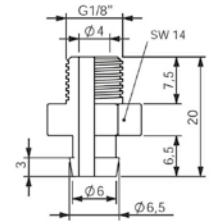
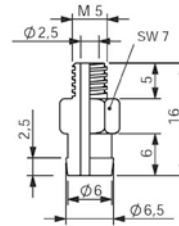
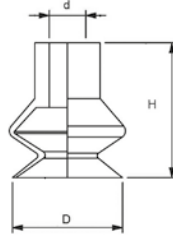
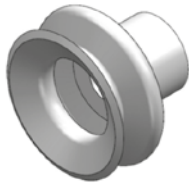

Part No. Silicone	Part No. TempFlex HT	Bellow	D	d	H	M5 Fitting	1/8 Fitting
CL-1.5-11-S	CL-1.5-11-HT	1,5	11	5	16	130.013	130.003
CL-1.5-14-S	CL-1.5-14-HT	1,5	14	5	16	130.013	130.003
CL-1.5-16-S	CL-1.5-16-HT	1,5	16	5	19	130.013	130.003
CL-1.5-20-S	CL-1.5-20-HT	1,5	20	5	16	130.013	130.003
CL-1.5-25-S	CL-1.5-25-HT	1,5	25	5	23	130.013	130.003

**BELLOW VACUUM CUPS - 1,5 BELLOW, Ø33-Ø53**

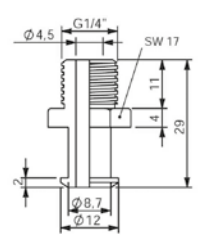
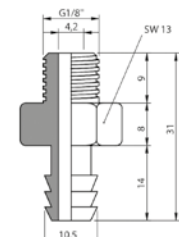
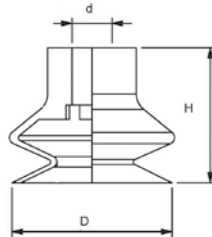
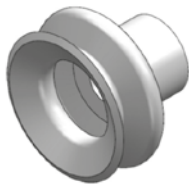

Part No. Silicone	Part No. TempFlex HT	Bellow	D	d	H	1/8 Fitting	1/4 Fitting
CL-1.5-30-S	CL-1.5-30-HT	1,5	33	8	28	130.132	130.190
CL-1.5-43-S	CL-1.5-43-HT	1,5	43	8	28	130.132	130.190
CL-1.5-53-S	CL-1.5-53-HT	1,5	53	8	34	130.132	130.190

**BELLOW VACUUM CUPS - 1,5 BELLOW, Ø15**

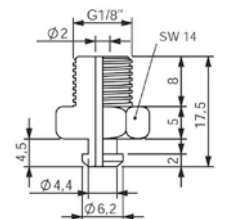
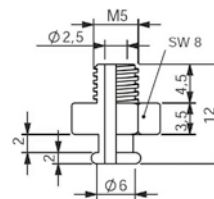
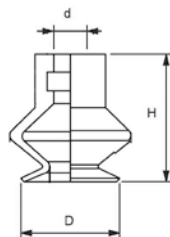
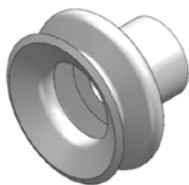

Part No. Silicone	Part No. TempFlex HT	Bellow	D	d	H	M5 Fitting	1/8 Fitting
CM-1.5-15-S	CM-1.5-15-HT	1,5	15	4	16	130.301	130.009

# VACUUM CUPS

## BELLOW VACUUM CUPS - 1,5 BELLOW, Ø20-Ø40

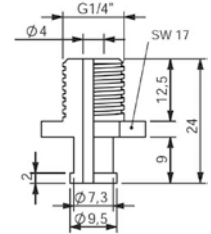
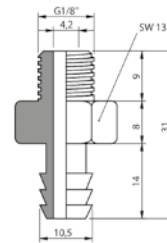
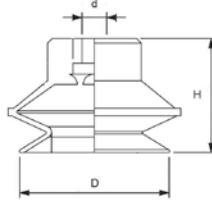

Part No. Silicone	Part No. TempFlex HT	Bellow	D	d	H	1/8 Fitting	1/4 Fitting
CM-1.5-20-S	CM-1.5-20-HT	1,5	20	6	22	130.030	130.274
CM-1.5-30-S	CM-1.5-20-HT	1,5	30	6	30,5	130.030	130.274
CM-1.5-40-S	CM-1.5-20-HT	1,5	40	6	30,5	130.030	130.274

## BELLOW VACUUM CUPS - 2,5 BELLOW, Ø 5 - Ø 25

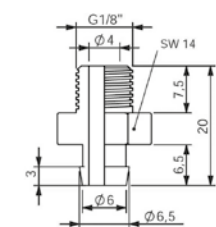
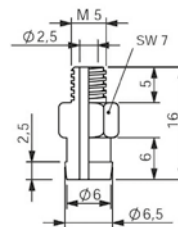
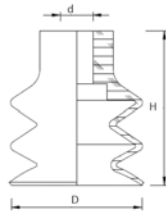

Part No. Silicone	Part No. TempFlex HT	Bellow	D	d	H	M5 Fitting	1/8 Fitting
CL-2.5-5	CL-2.5-5-HT	3	2,5	5	3,5	130.013	130.003
CL-2.5-7	CL-2.5-7-HT	3	2,5	7	4	130.013	130.003
CL-2.5-9	CL-2.5-9-HT	2	2,5	9	4	130.013	130.003
CL-2.5-12	CL-2.5-12-HT	8,5	2,5	12	4	130.013	130.003
CL-2.5-14	CL-2.5-14-HT	11	2,5	14	4	130.013	130.003
CL-2.5-20	CL-2.5-20-HT	8	2,5	20	4	130.013	130.003
CL-2.5-25	CL-2.5-25-HT	19	2,5	25	4	130.013	130.003

## BELLOW VACUUM CUPS - 2,5 BELLOW, Ø 32 - Ø 42

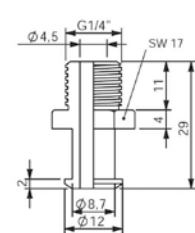
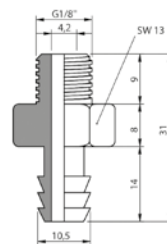
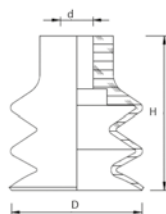

Part No. Silicone	Part No. TempFlex HT	Bellow	D	d	H	M5 Fitting	1/8 Fitting
CL-2.5-32	CL-2.5-32-HT	13	2,5	32	8	130.132	130.190
CL-2.5-42	CL-2.5-42-HT	13	2,5	42	8	130.132	130.190

Mouldpro Multiflex vacuum cups offer outstanding advantages

- Extremely high wear resistance
- Very high lifting force
- Best static friction qualities
- No sticking tendency
- Elasticity remains unchanged for minus temperatures
- Working temperatures from -20°C to + 80°C
- Antimarking



**VACUUM CUPS - 1,5 BELLOW, Ø 10 - Ø 50 MM**

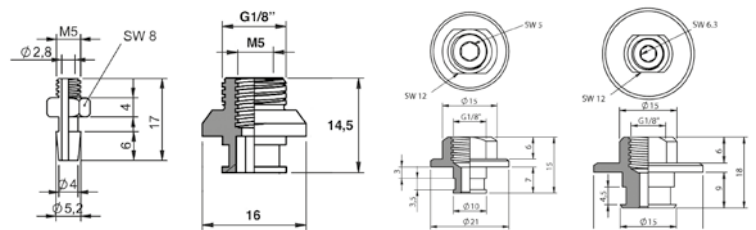
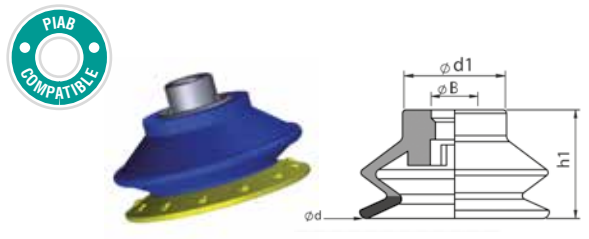

Part No.	d	B	d1	h1	Hardness	Part No.	Part No.	Part No.	Part No.
B15-10MF	5,5	10	3,9	9	16,5	40	F134		
B15-16MF	5,5	16	3,9	9	19	30/60	F134		
B15-20MF	7,6	21	5,2	12	18	30/60		F250	
B15-30MF	7,5	31	6,5	16,8	17	30/60			F251
B15-40MF	9,3	41	6,3	22,4	22,4	30/60			F251
B15-50MF	14,4	51	10,5	28	29,2	30/60			F252

**VACUUM CUPS - 2,5 BELLOW, Ø 20 - Ø 50 MM**

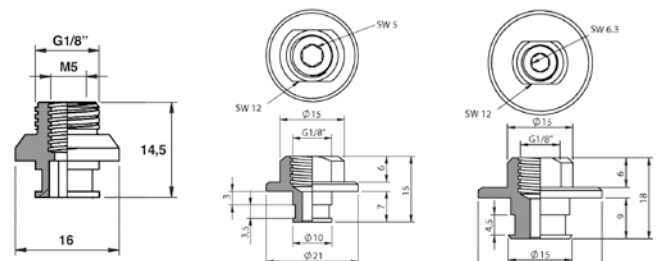
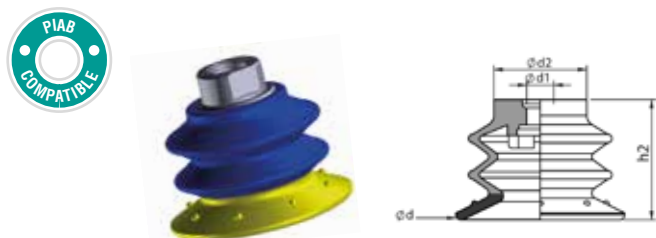

Part No.	d	d1	d2	h2	Hardness	Part No.	Part No.	Part No.
B25-20MF	6,5	20,5	5	12	14,8	30/60	F250	
B25-25MF	8	26	5	15,4	18,9	30/60	F250	
B25-30MF	11	30	5	16,5	21,3	30/60	F250	
B25-35MF	11	35	6,5	21	25,63	30/60		F251
B25-40MF	14,7	40	6,5	22	28,4	30/60		F251
B25-50MF	20	50	10,5	27,5	35,5	30/60		F252

# PNEUMATIC GRIPPERS

## PARALLEL GRIPPER

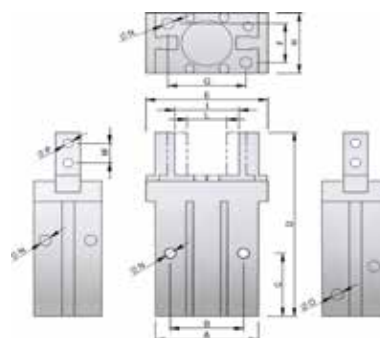
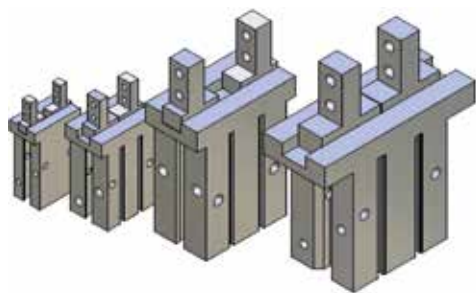

Part No.	Bore size	A	B	C	D	E	F	G	H	I open	L closed	Stroke	M	N	O	P	Force (N) Open/Close
PG-10	10	23	16	23	57	29	12	18	16.4	15,2	11.2	4	5.7	M3	M3	M2.5	22 / 34
PG-16	16	30.6	24	24.5	67.3	38	15	22	23.6	20,9	14.9	6	7	M4	M5	M3	68 / 90
PG-20	20	42	30	29	84.8	50	18	32	27.6	26,3	16.3	10	9	M5	M5	M4	84 / 132
PG-25	25	52	36	30	102.7	63	22	40	33.6	33,3	19.3	14	12	M6	M5	M5	130 / 208

## JAWS FOR GRIPPER

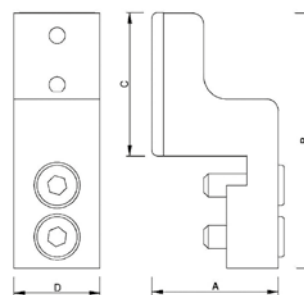
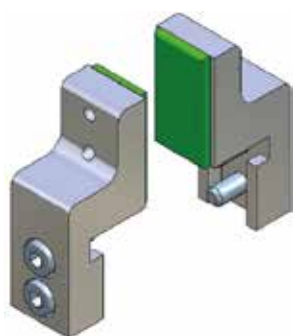

Part No.	Insert	A	B	C	D	Gripper Ref.	Weight
MA.KB.10	GRF14.95.08	15.5	27	14	10	PG-10	14 g
MA.KB.16	GRF20.95.08	18.5	35	20	15	PG-16	28 g
MA.KB.20	PAC.20.16P03	22	44.5	25	15	PG-20	41 g
MA.KB.25	PAC.20.16P03	29	55	25	20	PG-25	73 g

## GRIPPER ADAPTOR

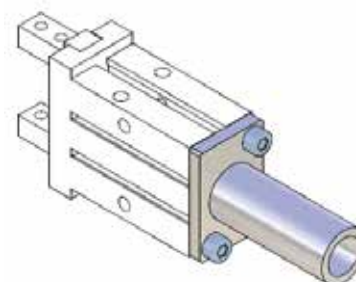
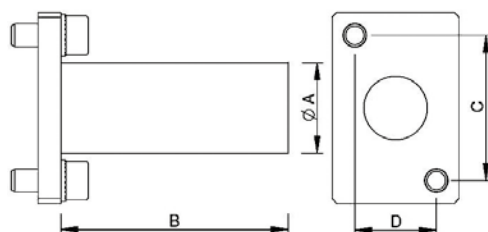
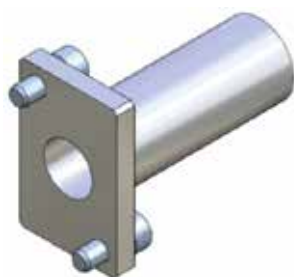

Part No.	A	B	C	D	Gripper Ref.	Weight
GA-10	10	30	18	12	PG-10	11 g
GA-16	14	40	22	15	PG-16	21 g
GA-20	20	50	32	18	PG-20	38 g
GA-25	20	50	40	22	PG-25	55 g



**JAW RUBBER PADS**

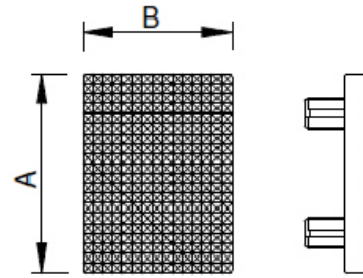

Part No.		Color	A	B	Jaw Ref.	Weight
TPU-10	TPU	■	14	10	MA.KB.10	1 g
TPU-16	TPU	■	20	15	MA.KB.16	2 g
TPU-20	TPU	■	30	20	MA.KB.20	3 g
TPU-25	TPU	■	30	20	MA.KB.25	1 g
FKM-10	FKM	■	14	10	MA.KB.10	3 g
FKM-16	FKM	■	20	15	MA.KB.16	1 g
FKM-20	FKM	■	30	20	MA.KB.20	2 g
FKM-25	FKM	■	30	20	MA.KB.25	3 g

**Description**

TPU = Thermoplastic Polyurethane  
 FKM = VITON (Fluoroelastomer)

# PNEUMATIC GRIPPERS

## SPRUE GRIPPERS GZ20

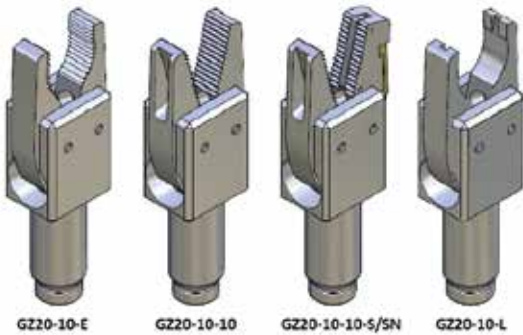

**Work principle:**

Single acting.

**Working pressure:**

6 bar clean and dry air.

**Material:**

Jaws made of hard-coated Aluminium / Body made of anodized Aluminium.

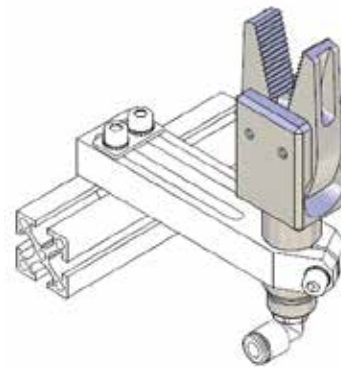
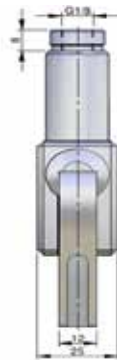
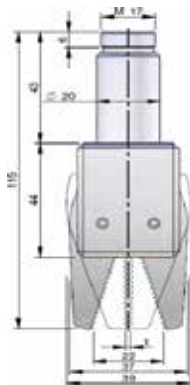

Part No.	Jaw Type	Sensor Type	Grip Force (6 bar)	Weight (g)
GZ20-10-10	Standard Cut		90 N	120
GZ20-10-10-S	Standard Cut	PNP (M8)	90 N	130
GZ20-10-10-SN	Standard Cut	NPN (M8)	90 N	130
GZ20-10-E	Curved - Standard cut		90 N	120
GZ20-10-L	Curved - Smooth		90 N	130

## REPLACEMENT SENSORS

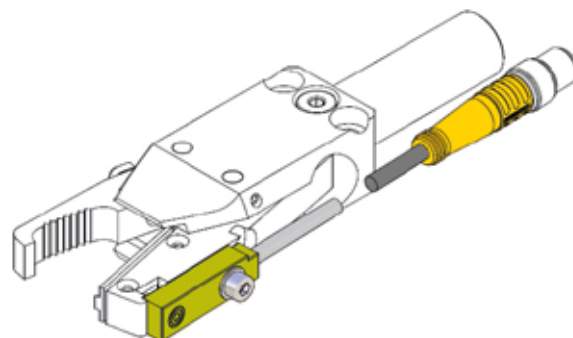
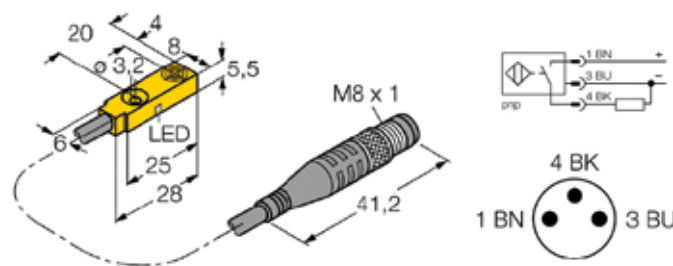

Part No.	Type	Cable length	Connection
GZ20-SM8-PNP	PNP	300	M8
GZ20-SM8-NPN	NPN	300	M8

**SPRUE GRIPPER TYPE GZ..**

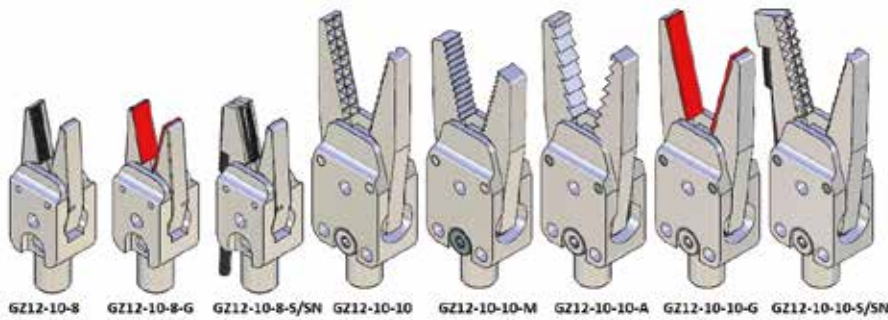

**Work principle:**

Single acting.

**2 different fastening possibilities:**

Clamp- Ø 10 mm on shaQ / Through-Thread in the gripper body.

Working pressure: 6 bar clean and dry air.

**Material:**

Jaws made of hard-coated Aluminium.

Body made of anodized Aluminium.

**SPRUE GRIPPER GZ12-10-8**

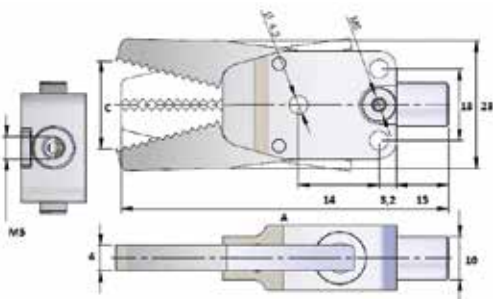

Part No.	C	A	Jaw Type	Sensor Type	Grip Force (6bar)	Weight (g)
GZ12-10-8	14	63,9	Standard Cut		19N	30
GZ12-10-8-G	14	63,9	TPU Rubber		19N	30
GZ12-10-8-S	11	61,8	Standard Cut	PNP (M8)	19N	30

**SPRUE GRIPPER GZ12-10-10**

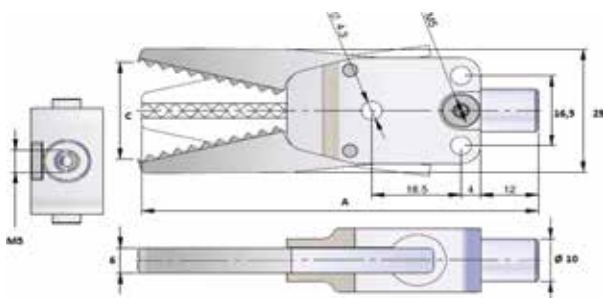

Part No.	C	A	Jaw Type	Sensor Type	Grip Force (6bar)	Weight (g)
GZ12-10-10	22,85	82	Diamond Cut		30N	40
GZ12-10-10-M	19,5	75,3	Standard Cut		30N	40
GZ12-10-10-A	22	82	Saw Cut		30N	40
GZ12-10-10-G	24	82	TPU Rubber		30N	40
GZ12-10-10-S	25	82	Diamond Cut	PNP (M8)	30N	50

# PNEUMATIC GRIPPERS

## RUBBER JAW PADS



Part No.	Type	Fit Gripper Model	Colour
GZ-TPU-4	TPU	GZ12-10-8-G	Grey
GZ-VIT-4	FKM	GZ12-10-8-G	Green
GZ-TPU-6	TPU	GZ12-10-10-G	Grey
GZ-VIT-6	FKM	GZ12-10-10-G	Green

**Description**

TPU = Thermoplastic Polyurethane  
 FKM = VITON (Fluoroelastomer)

## SENSORS

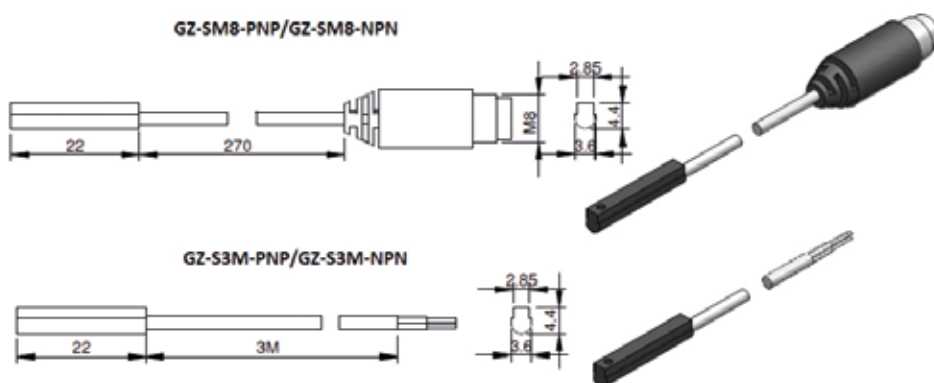

Part No.	Type	Cable length	Connection
GZ-SM8-PNP	PNP	270	M8
GZ-S3M-PNP	PNP	3000	-

## SPRUE GRIPPER

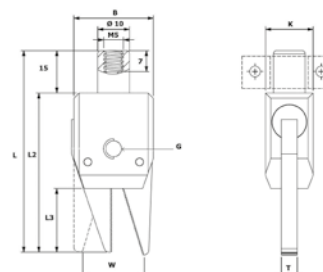
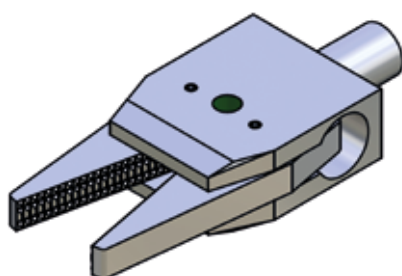

Part No.	W	T	L3	L2	G	L	K	Grip Force	B
MSG30	6,0	3	12	30	M4	45	8	10 N	15
MSG40	9,4	4	16	40	M6	55	10	15 N	20
MSG50	14,0	5	20	50	M6	66	12	23 N	25
MSG60	16,3	6	24	60	M6	76	14	31 N	30

**Description**

Compressed air supply: max. 6 bar  
 Temperature range: +5°C to +70°C

**FINGER GRIPPER TYPE GF**

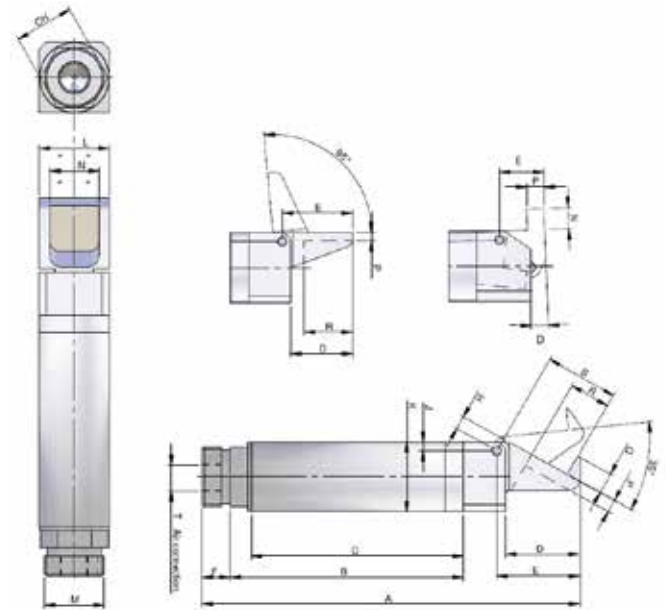
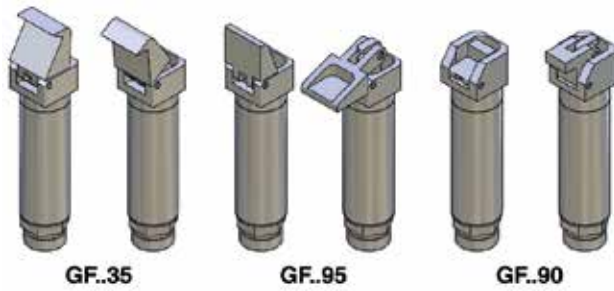

**Work principle:**

Single acting.

**Working pressure:**

6 bar clean and dry air.

**Material:**

Silver anodized Aluminium.

Part No.	Movement angle	Grip force	A	B	C	D	E	F	G	H	J	K	L	M	N	P	R	S	T	CH
GF14-35	35°	26 N	77	47,5	43,5	14	16	5,5	4,5	3,4	2	Ø14	14	M12X1	10	2	6	13,5	M5	12
GF20-35		100 N	107	66	60	21	23,5	8	6	3,8	2,5	Ø20	20	M17X1	14	3	11,5	20,7	G1/8	17
GF30-35		430 N	156	100	92	30	34	11	8	6	4	Ø30	30	M27X1	22	5	17	30,8	G1/8	27
GF14-90	90°	19 N	69	45,5	41,5	2°	8	5,5			2	Ø14	14	M12X1	10	4			M5	12
GF20-90		70 N	92,5	61	55	2°	13	8			2,5	Ø20	20	M17X1	14	5			G1/8	17
GF30-90		300 N	135	91	83	2°	20	11			4	Ø30	30	M27X1	22	6			G1/8	27
GF14-95	95°	19 N	75,5	47,5	43,5	12	14	5,5			2	Ø14	14	M12X1	10	2	9		M5	12
GF20-95		70 N	103,5	66	60	17,5	20	8			2,5	Ø20	20	M17X1	14	3	14		G1/8	17
GF30-95		300 N	148	100	90	25	29	11			4	Ø30	30	M27X1	22	5	21		G1/8	27

**FINGER GRIPPER TYPE GFR**

**Work principle:**

Single acting.

**Working pressure:**

6 bar clean and dry air.

**Material:**

Silver anodized Aluminium  
Viton Pads

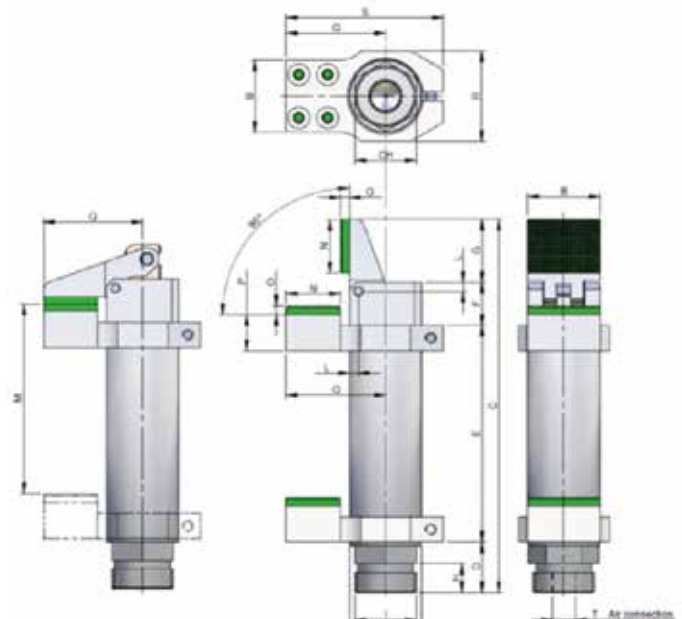

Part No.	Grip force	A	B	C	D	E	F	G	H	I	L	M	N	O	P	Q	R	S	T	CH
GFR1495	19 N	Ø 14	14	75,5	9,5	43,5	10,5	12	5,5	M12X1	2	38,5	10	2,5	6,5	19	17,5	30	M5	12
GFR2095	70 N	Ø 20	20	103,5	14	60	12	17,5	8	M17X1	2,5	52,5	15	2,5	10	27,5	25	43,5	G 1/8	17
GFR3095	300 N	Ø 30	30	148	20	90	15	25	11	M27X1	4	81	20	3	9	40	37	60	G 1/8	27

# PNEUMATIC GRIPPERS

## RUBBER PADS FOR FINGER GRIPPER

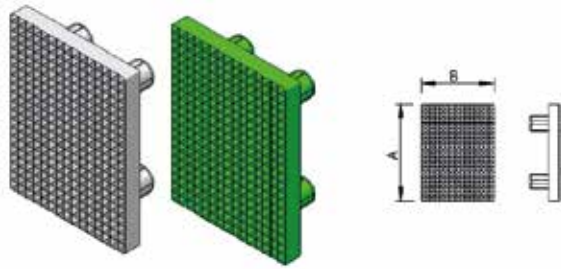

Part No.	Material	Color	A	B	M	Weight
GFR149508	TPU	Grey	14	10	GFR14..	1 g
GFR209508	TPU	Grey	20	15	GFR20..	2 g
GRF309508	TPU	Grey	30	20	GFR30..	3 g
GFR149508V	FKM	Green	14	10	GFR14..	1 g
GFR209508V	FKM	Green	20	15	GFR20..	2 g
GFR309508V	FKM	Green	30	20	GFR30..	3 g

**Description**

TPU = Thermoplastic Polyurethane  
 FKM = VITON (Fluoroelastomer)

## HOLDER FOR SPRUE CUTTER

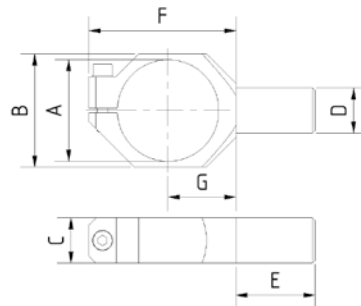
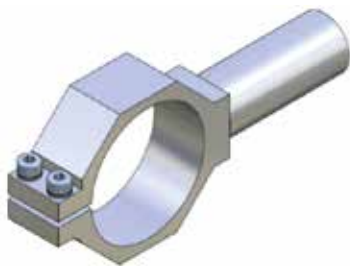

Item	A	B	C	D	E	F	G
SCH-10	36	43	20	20	48	60	28
SCH-20	45	52	20	20	48	68	33
SCH-30	56	54	20	20	48	80	38

**Description**

- Strong version
- For securely holding the sprue cutter ASZ

**PNEUMATIC GATE CUTTERS**



Mouldpro nippers are top quality and perform reliably.

The nipper body housings are made of aluminum, and are lighter than comparable Nile® or OEM® nippers. Mouldpro nippers have two available input ports for compressed air. Use one while the other is plugged. Mouldpro nippers also have bottom mounting holes for mounting possibilities in addition to body clamps.

**CYLINDER / PNEUMATIC NIPPER BODY**

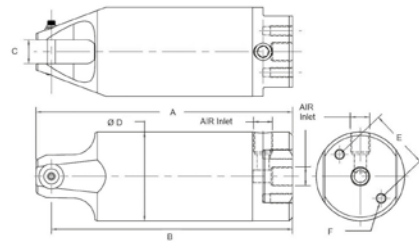

Part No.	Sprue Ø Cut	A	ØD	B	C	E	F	Cutting Pressure	Working Air Pressure	Air Port	Weight
SPT-10R	4 mm	114	36	110	12	24	M4x10	60 kg	4-6 Bar	G 1/8"	162 g
SPT-20R	7mm	130	45	126	12	30	M5x12	140 kg	5-6 Bar	G 1/8"	272 g
SPT-30R	10mm	166	56	163	17	40	M6x12	280 kg	5-6 Bar	G 1/8"	508 g

**STANDARD BLADE, 15 DEGREE ANGLE**

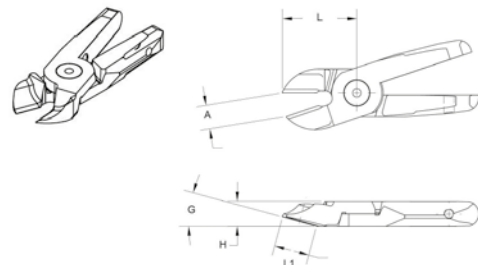

Part No.	Size	A	L	L1	H	G
GPT-10-ST	10	11	36	17	12	15°
GPT-20-ST	20	11	36	17	12	15°
GPT-30-ST	30	18	63	36	17	15°

**INLINE, STRAIGHT BLADE**

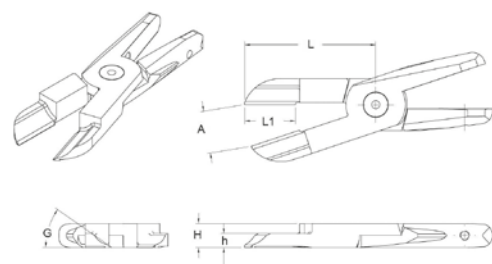

Part No.	Size	A	L	L1	H	h	G
GPT-10-LI	10	19	41	19	12	7	30°
GPT-20-LI	20	21	66	25	12	7	35°
GPT-30-LI	30	22	77	29	17	8	35°

## PNEUMATIC GATE CUTTERS

### STANDARD BLADE DEEP ANGLE 40/30 DEGREE

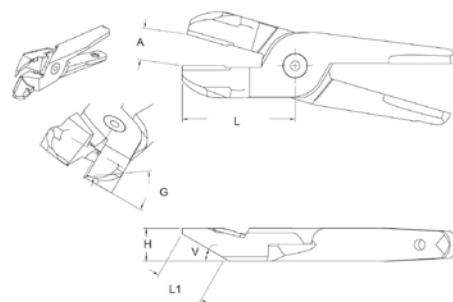

Part No.	Size	A	L	L1	H	V	G
GPT-10-DA	10	7	36	15	12	40°	35°
GPT-20-DA	20	11	36	15	12	40°	35°
GPT-30-DA	30	16	58	25	17	30°	35°

### LONG BLADE DEEP ANGLE 40/30 DEGREE

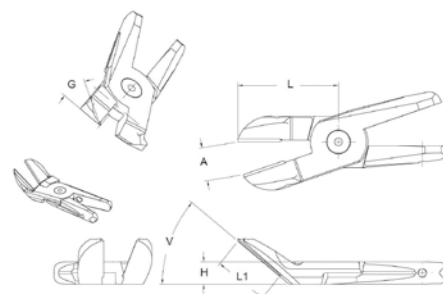

Part No.	Size	A	L	L1	H	V	G
GPT-10-LA	10	8	51	26	12	40°	30°
GPT-20-LA	20	17	53	29	12	40°	30°
GPT-30-LA	30	23	83	53	17	30°	30°

### LONG BLADE 90 DEGREE ANGLE

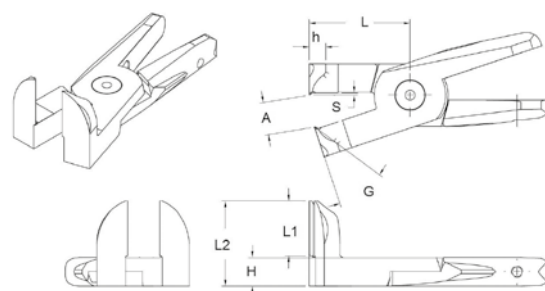

Part No.	Size	A	L	L1	L2	G	H	h	S
GPT-20-DA90	20	13	42	23	35	35°	12	7	1
GPT-30-DA90	30	11	39	33	52	35°	17	8	2



**PERPENDICULAR END CUT**

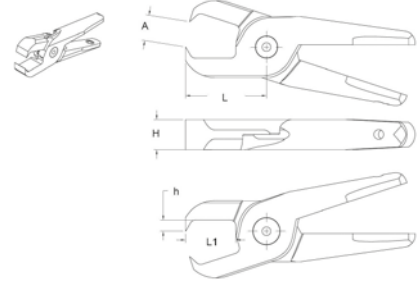

Part No.	Size	A	L	L1	H	h
GPT-20-PE	20	9	28	12	12	4
GPT-30-PE	30	14	46	28	17	6

**LONG PERPENDICULAR END CUT**

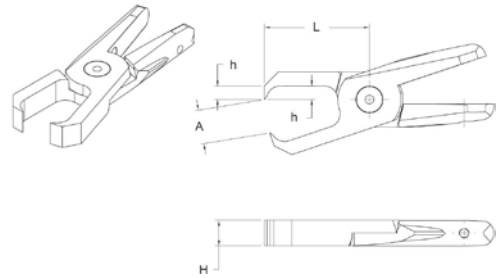

Part No.	Size	A	L	H	h
GPT-20-PELA49	20	16	49	12	6

# PNEUMATIC PUSH-IN FITTINGS

## PNEUMATIC PUSH-IN FITTING

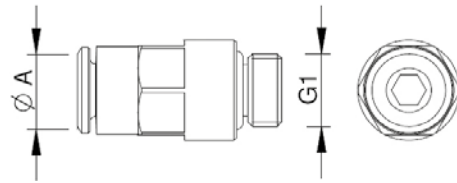

Part No.	Ø A	G1	
MSM04M5	4	M5	10
MSM04G1/8	4	G 1/8	10
MSM06M5	6	M5	10
MSM06G1/8	6	G 1/8	10
MSM06G1/4	6	G 1/4	10
MSM08G1/4	8	G 1/4	10
MSM08G3/8	8	G 3/8	10

### Description

Material: Technopolymer / Brass (Nickel Plated)  
 Pressure: Max 10 bar  
 Temperature: 0°C to +60°C

## SWIVEL ANGLE CONNECTOR

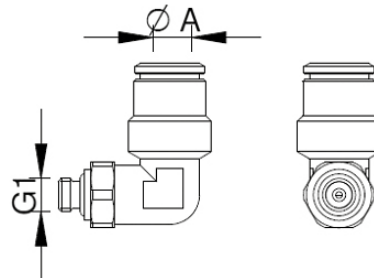

Part No.	Ø A	G1	
MSW04M5	4	M5	10
MSW06M5	6	M5	10
MSW06G1/8	6	G 1/8	10
MSW08G1/4	8	G 1/4	10

## THREADED Y CONNECTOR

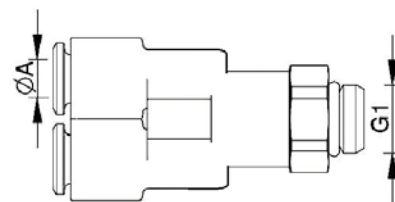

Part No.	Ø A	G1	
MSTY04G1/8	4	G 1/8	10
MSTY06G1/8	6	G 1/8	10
MSTY08G1/4	8	G 1/4	10

**Y CONNECTOR**

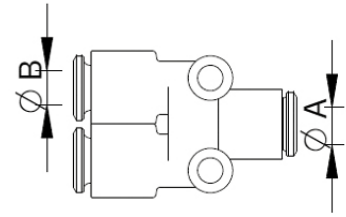

Part No.	Ø A	Ø B	
MSY04	4	4	10
MSY06	6	6	10
MSY08	8	8	10

**THREADED T-CONNECTOR**

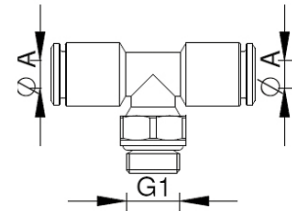

Part No.	Ø A	G1	
MSA04M5	4	M5	10
MSA04G1/8	4	G 1/8	10
MSA06M5	6	M5	10
MSA06G1/8	6	G 1/8	10
MSA08G1/4	8	G 1/4	10

**T-CONNECTOR**

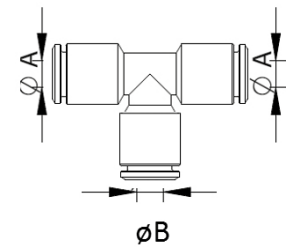

Part No.	Ø A	Ø B	
MST04	4	4	10
MST06	6	6	10
MST08	8	8	10

**PUSH-IN TUBE - POLYURETHANE**



Part No.	D (mm)	D1 (mm)	Working pressure	Bend radius	Coil Length L
PPU4B	4	2	Max 10 bar	20 mm.	30 m.
PPU6B	6	4	Max 10 bar	30 mm.	30 m.
PPU8B	8	6	Max 10 bar	31 mm.	30 m.

# 07.

## END OF BARREL

**173**

07.1 REMOVABLE NOZZLE TIPS



**174**

07.2 SCREW TIPS



**174**

07.3 TIP SPANNER



**176**

07.4 NOZZLE BODY ADAPTORS



**The MOULDPRO Removable Nozzle Tip System saves Time and Money!**

The Quick Change nozzle tip system was developed to offer a fast and economical solution for injection moulders to adapt their moulding machines to different tools and materials.

By replacing the manufacturer's nozzle body with the MOULDPRO replaceable tip design the moulder can benefit from using MOULDPRO standard 'quick change' replaceable tips.

The tips are available in different lengths, with different tip radius and orifice; the tips are available as General Purpose / Nylon Reverse Taper or ABS Full Taper.



- High Quality
- Hardened Tool Steel
- All Standard Sizes in Stock
- Standardise your factory and Save Money
- Standardise Size of Nozzle Heater Bands
- Custom designs available

**REMOVABLE NOZZLE TIPS**

General Purpose Type		Nylon Type		Full Taper				
Part Number	Part Number	Part Number	Thread Type	Total Length	Radius	Orifice Ø		
GP1-R12.7-1.5			7/8" UNF	38	12,7	1,5		
GP1-R12.7-2						2		
GP1-R12.7-2.5						2,5		
GP1-R12.7-3	NRT1-R12.7-3	FT1-R12.7-3				3		
GP1-R12.7-4	NRT1-R12.7-4	FT1-R12.7-4				4		
GP1-R12.7-5	NRT1-R12.7-5	FT1-R12.7-5				5		
GP1-R12.7-6.5	NRT1-R12.7-6.5	FT1-R12.7-6.5				6,5		
GP1-R12.7-8	NRT1-R12.7-8	FT1-R12.7-8				8		
GP1-R15-1.5					15	38	1,5	
GP1-R15-2.5							2,5	
GP1-R15-3	NRT1-R15-3	FT1-R15-3					3	
GP1-R15-4	NRT1-R15-4	FT1-R15-4					4	
GP1-R15-5	NRT1-R15-5	FT1-R15-5					5	
GP1-R15-5.5	NRT1-R15-5.5	FT1-R15-5.5					5,5	
GP1-R15-6.5	NRT1-R15-6.5	FT1-R15-6.5					6,5	
GP1-R15-7	NRT1-R15-7	FT1-R15-7					7	
GP1-R15-8	NRT1-R15-8	FT1-R15-8		8				
GP1-R15-9.5	NRT1-R15-9.5	FT1-R15-9.5		9,5				
GP1-R19-3	NRT1-R19-3	FT1-R19-3		19	38		3	
GP1-R19-4	NRT1-R19-4	FT1-R19-4					4	
GP1-R19-5.5	NRT1-R19-5.5	FT1-R19-5.5					5,5	
GP1-R30-3	NRT1-R30-3	FT1-R30-3		30			3	
GP1-R30-7	NRT1-R30-7	FT1-R30-7					7	
GP2-R12.7-3	NRT2-R12.7-3						70	12,7
GP2-R19-3	NRT2-R19-3			19				
GP3-R12.7-3	NRT3-R12.7-3			95	3			
GP4-R12.7-3	NRT4-R12.7-3				127			

**Description**  
Removeable Nozzle tips, Heat Treated Tool Steel, Polished Radius and Bore

# SCREW TIPS / TIP SPANNER

## SCREW TIP ASSEMBLY



Part No.	Diameter
STA-18	18mm
STA-20	20mm
STA-22	22mm
STA-25	25mm
STA-27	27mm
STA-28	28mm
STA-30	30mm
STA-32	32mm
STA-33	33mm
STA-35	35mm
STA-37	37mm
STA-38	38mm
STA-40	40mm
STA-42	42mm
STA-43	43mm
STA-45	45mm
STA-47	47mm
STA-48	48mm
STA-50	50mm
STA-52	52mm
STA-55	55mm
STA-60	60mm
STA-62	62mm
STA-65	65mm

Part No.	Diameter
STA-67	67mm
STA-70	70mm
STA-72	72mm
STA-75	75mm
STA-78	78mm
STA-80	80mm
STA-85	85mm
STA-90	90mm
STA-95	95mm
STA-100	100mm
STA-105	105mm
STA-110	110mm
STA-120	120mm
STA-125	125mm
STA-130	130mm
STA-135	135mm
STA-140	140mm
STA-150	150mm
STA-155	155mm
STA-160	160mm
STA-170	170mm
STA-180	180mm
STA-190	190mm
STA-200	200mm

**Description**

For all popular makes of moulding machine  
 Complete nitrided screw tip assembly including Screw Tip, Check Ring and Pressure Ring.  
 Please advise machine make / model / tonnage and screw size when ordering

## SCREW TIP SPANNER



Part No.	Screw tip Size
123894	Max 75 mm

**Description**

Tip spanner, ideal for fast and safe Screw tip replacement.  
 Adjustable for Screw Tips up to 75mm, 3, 4, 5 Flute.  
 Foam Grip

## LEATHER GLOVES



Part No.	Size
WG08/R8	MULTI

**Description**

Ideal for handling hot machine parts.  
 Rated up to 200°C EN-407

# CUSTOM NOZZLE TIP FORM

## SPECIFY

### 1. External Style of Nozzle Tip:

Standard     Flat Face\*

### 2. Internal Design of Nozzle Tip:

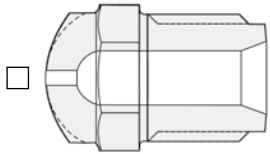

General Purpose Internal Design

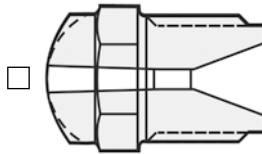

Nylon Internal Design

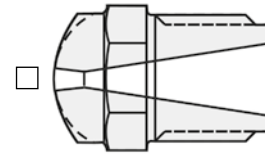

Full Taper Internal Design

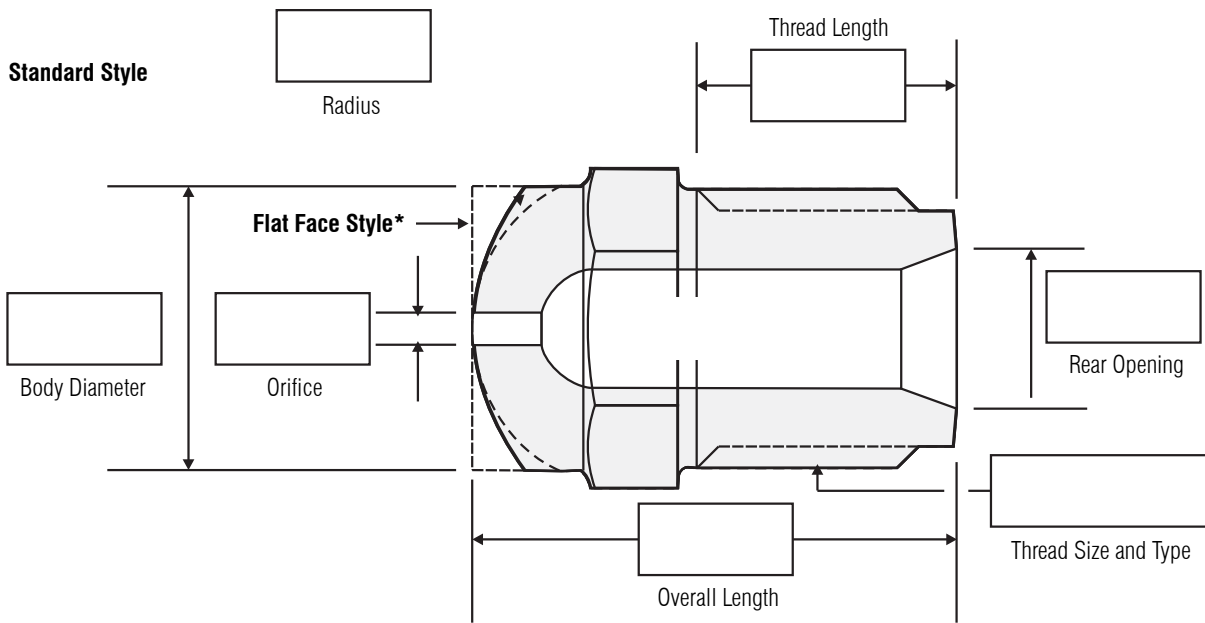

Date: \_\_\_\_\_ Quantity: \_\_\_\_\_ Phone: \_\_\_\_\_

Name \_\_\_\_\_ Title \_\_\_\_\_

Company \_\_\_\_\_ Email \_\_\_\_\_

Address \_\_\_\_\_

City \_\_\_\_\_ Zip \_\_\_\_\_

Country \_\_\_\_\_

**REMOVABLE NOZZLE TIPS**

**ORDER FORM**

**NOZZLE BODY**

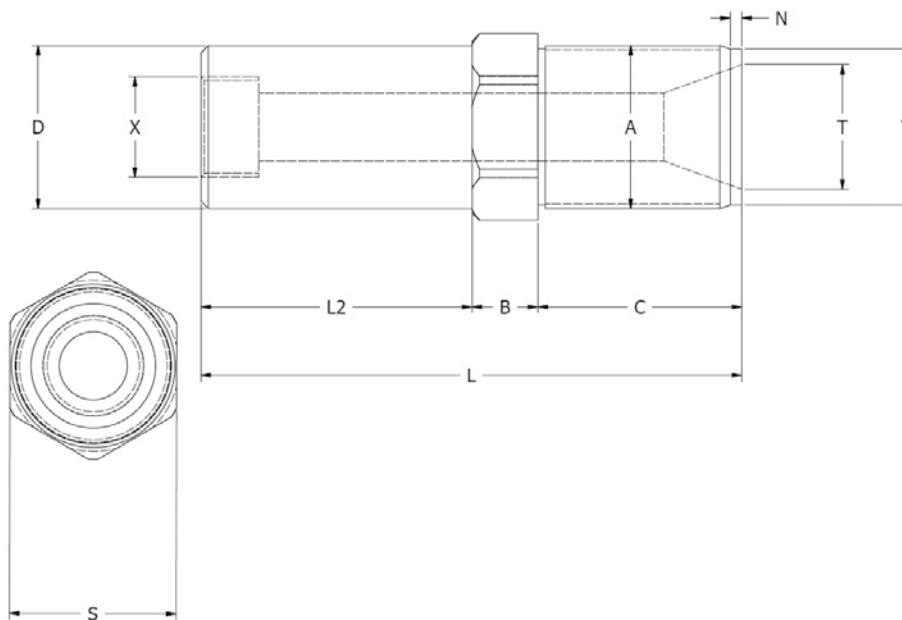

L	L2	B	C	D	X	T	Y	A	N	S

Metric only (mm)

Machine/Model \_\_\_\_\_

Company \_\_\_\_\_

Contact \_\_\_\_\_

Telephone \_\_\_\_\_

Contact e-mail \_\_\_\_\_



# ORDER FORM

## SOLID NOZZLE

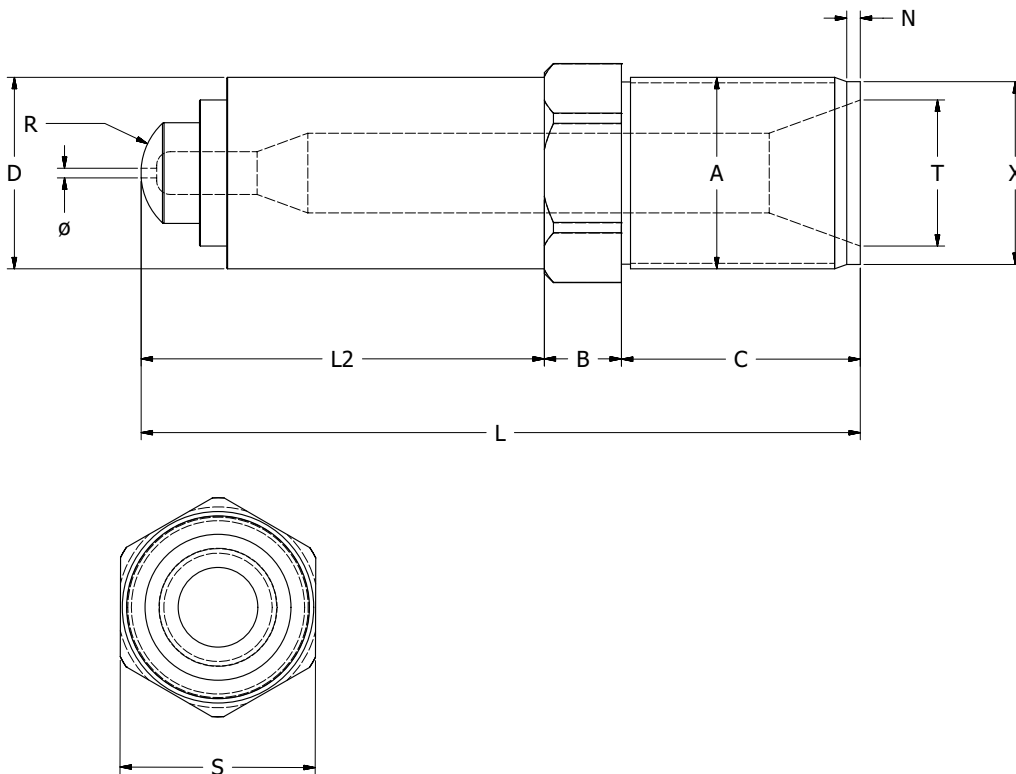

L	L2	B	C	D	X	R	Ø	T	A	N	S

Metric only (mm)

Machine/Model \_\_\_\_\_

Company \_\_\_\_\_

Contact \_\_\_\_\_

Telephone \_\_\_\_\_

Contact e-mail \_\_\_\_\_

# 08.

## TOOLS & ACCESSORIES

**179**

**08.1 GATE CUTTERS**



**183**

**08.2 DEBURRING TOOLS**



**184**

**08.3 SOFT TOOLS**



**187**

**08.4 ACCESSORIES**



**190**

**08.5 POLISHING & ABRASIVES**



**195**

**08.6 BRUSHES**



**197**

**08.7 COMPRESSED AIR BLOW GUNS**



**198**

**08.8 BORESCOPIES**



**199**

**08.9 MEASURING TOOLS**



**201**

**08.10 MAGNIFYING GLASSES**



**GATECUTTER 15° FLUSH CUT**



Part No.	Cut Type	Size	Handle Type
P40	15° - flush cut	4" / 100 mm	Plastic Grip
P50	15° - flush cut	5" / 125 mm	Plastic Grip
P60	15° - flush cut	6" / 150 mm	Plastic Grip

**GATECUTTER 40° FLUSH CUT**



Part No.	Cut Type	Size	Handle Type
P60-40	40° - flush cut	6" / 150 mm	Plastic Grip

**GATECUTTER 90° FLUSH CUT**



Part No.	Cut Type	Size	Handle Type
P60-90	90° - flush cut	6" / 150 mm	Plastic Grip

**Description**

High quality alloy steel.  
 Coil spring return provides fast smooth action and improves productivity.  
 Induction hardened cutting edge.  
 Black oxide, anti-glare finish reduces visual fatigue and corrosion.

# GATE CUTTERS

## HEATED GATE CUTTERS



Part No.	Blade Length (mm)	Blade Type	Size (mm)	Cut capacity (mm)	Weight	
HT-120	10	End Cut	150	ø 4	270 g	
HT-130	27	Long	165	ø 4	270 g	
HT-140	22	Flat	160	ø 4	265 g	
HT-160	16	Narrow	150	ø 4	240 g	
HT-170	22	Angle	150	ø 4	250 g	
HT-180	16	Standard	190	ø 4	250 g	
HT-200	23	Heavy Duty 29 Watt	190	ø 7	375 g	

**TRANSFORMER FOR HEATED GATE CUTTERS**



Part No.	Power Input	Voltage output	Size (mm)
MHN-PS01	110-240V.	24 V.	45x110x165

**SPARE HEATING ELEMENT**



Part No.	Power input	Heat Effect
W-19	24 V	19 Watt
W-29	24 V	29 Watt



**PREMIUM  
TOOLS FOR  
PROFESSIONALS**

**Ceramic Knife**

Ideal for curved and complicated shapes;  
Excels on ultra-hard resins like Glass-fiber, carbon-fiber and talc filled plastics.

Also it can be used on soft metals like aluminum, copper and brass.

- Space age ceramics make safe deburring possible because of Work-finisher's unique non-blade like edge. (No sharp edge)
- Deburrs hard plastics effortlessly without the fear of cutting your hand or fingers in the process. (Very safe knife)
- Can be used for surface finishing the plastics moulding parts, very small, very confined areas, narrow, concave area or complex portion.



**CERAMIC KNIFE**



Part No.	Blade material	Length	Blade dimension	Blade Profile	
MWF133	Ceramic 1250 HV	133 mm	25 x 5 mm	Convexed	1

**CERAMIC KNIFE**



Part No.	Blade material	Length	Blade dimension	Blade Profile	
MWF175	Ceramic 1250 HV	175 mm	40 x 14 mm	Convexed	1

**DE-BURRING TOOL**



Part No.	Type	Blade Material	No. of blades	Blade size $\phi$	
E02000	Handle	Steel	1	3,2	1
BS1010	Replacement blades	Steel	10	3,2	1

## SOFT TOOLS

### BRONZE PLIERS ANGLED, SHORT



Part No.	Description	Size	
BC60	60° Needle Nose	6" / 150 mm	1

### BRONZE PLIERS ANGLED, LONG



Part No.	Description	Size	
BC90	60° Needle Nose	9" / 230 mm	1

### BRONZE PLIERS STRAIGHT, SHORT



Part No.	Description	Size	
BL60	Straight Needle Nose	6" / 150 mm	1



**BRONZE PLIERS STRAIGHT, LONG**



Part No.	Description	Size	
BL90	Straight Needle Nose	9"/ 230 mm	1

**BRONZE SIDE CUTTER**



Part No.	Description	Size	
BD60	Side Cutter	6"/ 150 mm	1

**Description**  
High quality Bronze Pliers, reduce risk of damaging the mould

**BEVELLED BLADE SCRAPER**



Part No.	Blade Width	Blade Length	Total Length	Material	
BSC125L	25 mm	177 mm	273 mm	Brass	1
BSC125	32 mm	100 mm	200 mm	Brass	1
BSC200	50 mm	100 mm	200 mm	Brass	1

## SOFT TOOLS

### ANGLED SCRAPER NO BEVEL



Part No.	Blade Width	Material	
BSC125A	32 mm	Brass	1

### KNOCK OUT BAR



Part No.	Description	Size	
704-31	Knock out Bar	ø 8	1
705-31	Replacement Bar	ø 8	1

#### Description

Simple but effective tool that combines a tough steel rod with threaded brass replaceable tips that prevent damage to the mould surface. The quickly replaced threaded brass tip ensures that the rod never gets too short or wears out and minimises the risk of burning. The steel rod never wears out and the end will not 'mushroom' like a solid brass rod.

- Steel Rod has an anti-rust finish
- Steel Rod has 10mm Flat for simple removal of used tips
- Brass Tip is machined to fine point
- Supplied complete with one replacement tip

Steel Rod: 13mm dia. / 420mm length  
 Brass Tip: 8mm dia. / 105mm length

### BRASS TOOLS



Part No.	Description	Length	
BRT5	5mm Diameter	350mm	1
BRT5/90	5mm Diameter / 90 Degree	350mm	1
BRT8	8mm Diameter	400mm	1
BRTK	Kit Comprising BRT5 / BRT5/90 / BRT8		1

#### Description

A range of brass hand tools manufactured from high grade brass for safely working on mould tools without damaging the mould surface; ideal for removing frozen sprues or stuck parts. The tips are supplied blunt and may be shaped to suit specific requirements.

**HOT TIP SPRUE CLEANER-AUTOMATIC**

Part No.	Watt	Temp. Range	Power	
PS6-5AUTO	200	350°C	230V.	1

**Description**

The Hot Tip Sprue Cleaner is a quick heating flexible tool for melting thermoplastics from plugged sprues and nozzles. When you squeeze the trigger the powerful heater immediately heats the tip to 350°C.

- 3 Copper Tips included
- Flexible Arm
- 2,5 meter cord
- Automatic timer: The integrated timer heats up the tip for approx. 10 seconds and then wait 50 seconds before next cycle is possible. A light will indicate heating action (green) and pause (red).

**REPLACEMENT TIPS FOR SPRUE CLEANER**

Part No.	Number	Description	Material
PS6-8	8	Straight Cone	Copper
PS6-9	9	Straight Blade	
PS6-10	10	90° Cone	
PS6-11	11	Straight Cylinder	
PS6-12	12	45° Cone	
PS6-13	13	45° Blade	
PS6-14	14	Straight Cylinder Slim	

## ACCESSORIES

### COPPER AND RAWHIDE MALLET



Part No.	Size	Ø	Weight	Length	
THO208	A	25 mm	355 g	230 mm	1
THO210	1	32 mm	710 g	270 mm	1
THO212	2	38 mm	1070 g	305 mm	1
THO214	3	44 mm	1600 g	305 mm	1
THO216	4	50 mm	2380 g	355 mm	1

#### Description

Malleable-iron head fitted with one face of pure copper, the other highly compressed buffalo rawhide.  
Wooden Handle

### NYLON HAMMER



Part No.	Face diameter	Weight	Length	
TH0710	32 mm	445 g	280 mm	1
TH0712	38 mm	650 g	305 mm	1
TH0714	44 mm	850 g	305 mm	1
TH0716	50 mm	1230 g	305 mm	1

#### Description

- Worn faces can be quickly replaced BY HAND providing minimum down time.
- All faces are one piece mouldings.
- There are no metal pegs or inserts which can damage the workpiece when worn.
- Serrations in the metal head prevent faces loosening in use.
- Faces have a shoulder for extra strength and to prevent fracture from misdirected blows.
- To suit a wide range of hammering applications 5 alternative hardness of screw-in faces are available – colour coded for easy identification.

### DEAD BLOW NYLON HAMMER



Part No.	Face diameter	Weight	Length	
TH01010	32 mm	550 g	275 mm	1
TH01212	38 mm	700 g	305 mm	1
TH01414	44 mm	900 g	310 mm	1
TH01616	50 mm	1150 g	325 mm	1
TH02020	63 mm	1850 g	370 mm	1

#### Description

Thorace dead blow hammers are a coated die-cast head and handle of aluminium alloy with shock absorbent rubber grip.  
The hollow head is partially filled with steel shot which adds to the weight, prevents rebound and delivers 'dead' blows of maximum impact.

**SPARE FACES**



Face Diameter		Soft Grey Shore A 63-73	Medium Red Shore D 45-55	Tough Brown PU Shore D 58-62	Hard White Nylon Shore D 57-61	Extra Hard Yellow Rockwell R103
32	10	THO-SG10	THO-MR10	THO-TB10	THO-HW10	THO-HY10
38	10	THO-SG12	THO-MR12	THO-TB12	THO-HW12	THO-HY12
44	10	THO-SG14	THO-MR14	THO-TB14	THO-HW14	THO-HY14
50	10	THO-SG16	THO-MR16	THO-TB16	THO-HW16	THO-HY16
63	10	-	-	THO-TB20	THO-HW20	-

**BALLPOINT L-HEX KEY SETS**



Part No.	Pieces in set	Sizes	Type	
BLX9	9	1.5-2-2.5-3-4-5-6-8-10 mm.	Metric	1
BLX13	13	3/64-1/16-5/64-3/32-7/64-1/8-5/32-9/64-3/16-7/32-1/4-5/16-3/8	Imperial	1

**Description**

Protanium® steel and are up to 20% stronger than competitor tools.  
 BriteGuard premium chrome-like finish is attractive, professional quality, and easy to clean.

## POLISHING AND ABRASIVES

### HANDPADS



Part No.	Size	Grade	Colour	
NHP021	155x225 mm	Fine	Green	1 (Bags of 10 pcs)
NHP006	155x225 mm	Very Fine	Maroon	1 (Bags of 10 pcs)
NHP008	155x225 mm	Ultra Fine	Light Grey	1 (Bags of 10 pcs)

**Description**

A range of general purpose handpads designed for cleaning and finishing applications

### COPPER GAUZE



Part No.	Width	Length	
CG30	130	30m.	1

**Description**

Knitted Copper, Reversible Soft Copper perfect for cleaning Screws etc.

**MINI GRINDING MACHINE**



Part No.	Speed	Voltage	Collet	Foot Control	
PP35SET	0-35.000 rpm	115/230 V.	3 mm	Yes	1

**SPARE COLLETS**



Part No.	Collet	
PP35C235	2,35 mm	1
PP35C300	3,00 mm	1
PP35C3175	3,175 mm	1

**DIAMOND POINTS SET**



Part No.	Grit size	Shank	
DP2030	D100	3 mm	1 (set of 30 pcs)

**CARBIDE BURRS SET**



Part No.	Cut type	Shank	
CB10S	Double cut	3 mm	1 (set of 10 pcs)

## POLISHING & ABRASIVES

### DIAMOND PASTE



Part No.	Micron	Size	
MPD1	1	5 gr.	1
MPD3	3	5 gr.	1
MPD6	6	5 gr.	1
MPD8	8	5 gr.	1
MPD14	14	5 gr.	1
MPD25	25	5 gr.	1

**Description**

High concentration diamond paste for rapid polishing and repair of moulds. Use with felt stick, wood sticks or points.

### DIAMOND NEEDLE FILE SET



Part No.	Description	Size	Grit Size	
DIAZ-5	Diamond Needle files	140 mm	D126	1

**Description**

Quality Diamond File Set, useful for working with steel, hardened steel, carbide and ceramic/glass materials.



**Mould Finishing Super Stones**

New SuperStone offers an improved cutting ability, longer life and an increased heat resistance of approximately 45% over the conventional type. New SuperStone can be used in ultrasonic polishing machines, electric micro grinders, reciprocating profilers, or by hand use with holder.

SuperStone can also be used on soft metals such as aluminium, copper and brass.

- Incredible strength and flexibility. It will offer excellent polishing ability even under every strenuous condition.
- Non-clogging. Beautiful polishing result on all types of metals in small and detailed areas.
- Available in any dimensions in flat/round profiles upon your demand.
- Available in grit 120 to 1200. Easy to identify by colour-coding.



**FLAT TYPE**



SIZE (mm) T x W x L	VIOLET (#80)	EMERALD (#120)	GOLD (#180)	L.BROWN (#300)	ORANGE (#400)	BROWN (#600)	BLUE (#800)	WHITE (#1000)	RED (#1200)	
0.8 x 4 x 100	NSV084	NSE084	NSG084	NSL084	NSO084	NSP084	NSB084	NSW084	NSR084	1
0.8 x 6 x 100	NSV086	NSE086	NSG086	NSL086	NSO086	NSP086	NSB086	NSW086	NSR086	1
1.0 x 4 x 100	NSV104	NSE104	NSG104	NSL104	NSO104	NSP104	NSB104	NSW104	NSR104	1
1.0 x 6 x 100	NSV106	NSE106	NSG106	NSL106	NSO106	NSP106	NSB106	NSW106	NSR106	1
1.5 x 4 x 100	NSV154	NSE154	NSG154	NSL154	NSO154	NSP154	NSB154	NSW154	NSR154	1
1.5 x 6 x 100	NSV156	NSE156	NSG156	NSL156	NSO156	NSP156	NSB156	NSW156	NSR156	1

**ROUND TYPE**



SIZE (mm) T x W x L	VIOLET (#80)	EMERALD (#120)	GOLD (#180)	L.BROWN (#300)	ORANGE (#400)	BROWN (#600)	BLUE (#800)	WHITE (#1000)	RED (#1200)	
1.5 x 6 x 100	NSV156	NSE156	NSG156	NSL156	NSO156	NSP156	NSB156	NSW156	NSR156	1

**STONE HOLDERS**

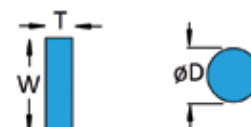

Part No.	W (mm)	T (mm)	D (mm)	
SSH-4	4	0,5 - 3	-	1
SSH-6	6	0,5 - 3	-	1
SNH-30	-	-	ø3	1

## POLISHING & ABRASIVES

### FELT BOBS - CYLINDRICAL

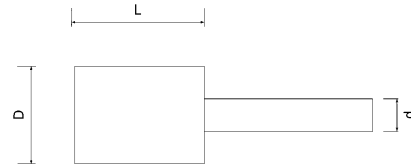

Part No.	D	L	d1	
FIL612C	6	12	3	1 (bag of 10 pcs)
FIL1012C	10	12	3	1 (bag of 10 pcs)
FIL1219C	12	19	3	1 (bag of 10 pcs)
FIL1632C	16	32	3	1 (bag of 10 pcs)
FIL1932C	19	32	6	1 (bag of 10 pcs)
FIL3238C	32	38	6	1 (bag of 10 pcs)

### FELT BOBS - CONE SHAPE

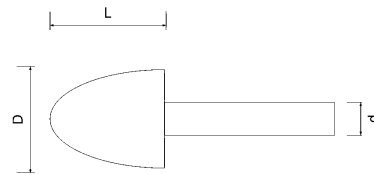

Part No.	D	L	d1	
FIL616K	6	16	3	1 (bag of 10 pcs)
FIL1012K	10	12	3	1 (bag of 10 pcs)
FIL1219K	12	19	3	1 (bag of 10 pcs)
FIL1625K	16	25	3	1 (bag of 10 pcs)
FIL1925K	19	25	6	1 (bag of 10 pcs)

### FELT STICKS - HARDENED



Part No.	d1	d2	L	
FIL66100	6	6	100	1 (bag of 10 pcs)
FIL1010150	10	10	150	1 (bag of 10 pcs)

### HARD WOOD LAPPING STICKS



Part No.	Shape	d1	d2	L	
LS3	Rectangular	3	4,5	150	1 (bag of 10 pcs)
LS6	Rectangular	6	4,5	150	1 (bag of 10 pcs)
LSS3	Square	3	3	150	1 (bag of 10 pcs)
LSS6	Square	6	6	150	1 (bag of 10 pcs)
LSR3	Round	ø3	ø3	150	1 (bag of 10 pcs)
LSR6	Round	ø6	ø6	150	1 (bag of 10 pcs)

**SMALL BORE CLEANING BRUSH (BRASS / NYLON) WITH LOOP HANDLE**



Part No. Brass	Part No. Nylon	Diameter	Brush Length	Total length	
-	SN2	2	100	300	1
SB3	SN3	3	100	300	1
SB4	SN4	4	100	300	1
SB5	SN5	5	100	300	1
SB6	SN6	6	100	300	1
SB8	SN8	8	100	300	1
SB10	SN10	10	100	300	1
SB12	SN12	12	100	300	1
SB15	SN15	15	100	300	1
SB20	SN20	20	100	300	1
SB25	SN25	25	100	300	1

**CONDENSER BRUSH**



Part No. Brass	Part No. Nylon	Diameter mm	Thread	Brush Length	Total Length	
CBB6	CBN6	6	M4	80	115	1
CBB8	CBN8	8	M6	80	115	1
CBB10	CBN10	10	M6	80	115	1
CBB12	CBN12	12	M6	80	115	1
CBB14	CBN14	14	M6	80	115	1
CBB16	CBN16	16	M6	80	115	1
CBB18	CBN18	18	M6	80	115	1
CBB20	CBN20	20	M6	80	115	1

**Description**

Single Spiral Brush with thread, ideal for cleaning inside bores.

**HAND BRUSH**



Part No.	Material	Rows	L	B	A	H	
HBM3-5	Brass	3 x 5	150	15	35	15	1
HBM5-10	Brass	5 x 10	190	24	55	12	1
HBM4-15	Brass	4 x 15	290	40	140	25	1

**Description**

Allround brushes with wooden handle. Perfect for cleaning surfaces without damaging the Mould parts.

# BRUSHES

## BARREL CLEANING BRUSHES



Part No.	Diameter mm	Diameter Inch	Thread	Brush Length	Total Length	
BC20	20	3/4"	W 3/8"	100	150	1
BC22	22	7/8"	W 3/8"	100	150	1
BC25	25	1"	W 3/8"	100	150	1
BC28	28	1-1/8"	W 3/8"	100	150	1
BC30	30	1-1/4"	W 1/2"	100	160	1
BC35	35	1-1/4"	W 1/2"	100	160	1
BC40	40	1-1/2"	W 1/2"	100	160	1
BC44	44	1-1/4"	W 1/2"	100	160	1
BC50	50	2"	W 1/2"	100	160	1
BC57	57	2-1/4"	W 1/2"	100	160	1
BC63	63	2-1/2"	W 1/2"	100	160	1
BC69	69	2-3/4"	W 1/2"	100	160	1
BC75	75	3"	W 1/2"	100	160	1
BC82	82	3-1/4"	W 1/2"	100	160	1
BC88	88	3-3/8"	W 1/2"	100	160	1
BC94	94	3-5/8"	W 1/2"	100	160	1
BC101	101	4"	W 1/2"	100	160	1
BC125	125	5"	W 1/2"	100	160	1
BC150*	150	6"	W 1/2"	100	160	1
BC200*	200	8"	W 1/2"	100	160	1

### Description

\* Single Spiral

Heavy Duty Double Spiral Steel Brush ideal for cleaning Barrel Cylinders of Injection Moulding Machines.

## HANDLES AND EXTENSIONS



Part No.	Thread	Type	Length	
HD1000	M4	Handle	1000 mm	1
ED1000	M4	Extension	1000 mm	1
HC1000	M6	Handle	1000 mm	1
EC1000	M6	Extension	1000 mm	1
HA1000	W 3/8"	Handle	1000 mm	1
EA1000	W 3/8"	Extension	1000 mm	1
HB1000	W 1/2"	Handle	1000 mm	1
EB1000	W 1/2"	Extension	1000 mm	1

**BLOW GUN IN FORGED ALUMINIUM**



Part No.	Working Pressure	Tube size	Tube Extended Length	Tube Block Length	Connection	
MBG-S	15 Bar	6,5x10	6 m.	490 mm	R 1/4"	1

**Description**

- Blow gun sets with Polyurethane Spiral Hose
- Polyamide bend - and scratch protection
- High quality, robust and handy design
- Useful for all applications

**BLOW GUN IN PLASTIC**



Part No.	Working Pressure	Tube size	Tube Extended Length	Tube Block Length	Connection	
MBG-P	15 Bar	6,5x10	6 m.	490 mm	R 1/4"	1

**Description**

- Blow gun sets with Polyurethane Spiral Hose
- Polyamide bend - and scratch protection
- High quality, robust and handy design
- Useful for all applications

## BORESCOPIES

### USB BORESCOPE - BH98



#### Description

Simple cost effective solution for identifying problems in hard to access areas; Plug the camera in with the USB cable and use the software to take photos / video and measurements on your laptop.

- 7.0mm Diameter Lens with 4 adjustable LED lights (waterproof)
- 6.4mm Diameter Flexible Tube x 830mm long
- 640 x 480 pixels Resolution
- 2 metre USB Cable
- CD with Software (Windows XP/Win 7/Vista)

### BORESCOPE - BV99



#### Description

- 3.5" TFT LCD Monitor 240 x 320 pixels
- Ø9.8mm Lens with 4 LED lights for adjustable illumination
- Ø6.8mm Detachable 1000mm Flexible Tube
- Camera Head and Tube IP67 waterproof
- Powered by 4x AA Battery (not included)
- Includes Magnetic Tip / Hook / Mirror Tools, Carry Case

### VIDEO BORESCOPE - BV99R



#### Description

Advanced design, flexible and convenient to use, this camera allows visual inspection of hard-to-reach areas which can help to identify problems within the mould or damage / wear inside the barrel of the machine.

- 3.5" TFT LCD Monitor 480 x 640 pixels with 5x Digital Zoom
- Photo, Video, Playback, Built-in speaker and microphone
- SD Storage Slot, AV Out, USB Interface
- Ø8.5mm Lens with 4 LED lights for adjustable illumination
- Ø6.8mm Detachable 1000mm Flexible Tube
- Camera Head and Tube IP67 waterproof
- Powered by 4x AA Battery (not included).
- Includes Magnetic Tip / Hook / Mirror Tools, Carry Case.

**DIGITAL CALIPER 0-150 MM**

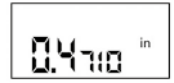
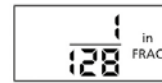
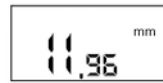

Part No.	Range (mm)	Resolution	Battery	
DC150	0-150	0,01 mm	1,55V (SR44W)	1

**RADIUS GAUGE - CONCAVE AND CONVEX FORM**

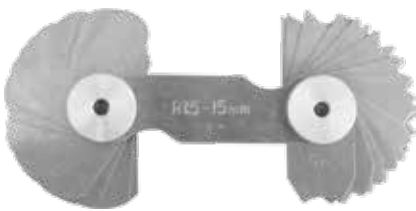

Part No.	Range (mm)	# Blades	
RG17	1,0-7,0	17	1
RG715	7,5-15,0	16	1
RG1525	15,5-25,0	15	1
RG2550	25,0-50,0	20	1

**THREAD PITCH GAUGE - METRIC, WHITWORTH, PIPE THREAD**



Part No.	Metric 60° Pitch/mm	Whitworth 55° Pitch/Inch	Pipe Thread 55° Pitch/Inch	# Blades	
SPG58	0,25-6,00	62-4	28RG-8RG	58	1

**STEEL RULER 300X30X1,0 MM/INCH - CHROME PLATED**



Part No.	Length (mm)	Width (mm)	Thickness (mm)	
SR300	300	30	1	1

## MEASURING TOOLS

### MOULDPRO TAPE MEASURE



Part No.	Coil length (m)	Width (mm)	
MPT5	5	19	1
MPT8	8	25	1

**Description**

Professional Quality Tape Measure with chrome plated tough ABS plastic case and integrated thumb lock.  
 High visibility anti-glare blade with polymer coating to extend blade life. Class 2 Blade 19mm (5m) / 25mm (8m) Wide Blade Metric / Imperial Scale. Compact & Durable Case.  
 3-Rivet True-Zero End Hook Belt Clip.

### MAGNETIC MOULD LEVEL



Part No.	Length (mm)	Width (mm)	Height (mm)	
MAGML	70	20	40	1

**Description**

This Pocket Pro Magnetic level is a professional quality spirit level that fits in the pocket, or can be attached to a belt with the clip supplied.  
 This little compact level has strong magnets that hold the level in place on horizontal or vertical surfaces.  
 This level can measure pipe surfaces with its v-groove base.  
 Accuracy in normal position: ± 1mm / m.



**HANDHELD MAGNIFIER 2,5X Ø90 MM - GLASS LENS AND 12 X LEDS**



Part No.	Magnification	Lens diameter	# LED lights	dimensions	
HM90	2,5 X	Ø 90 mm	12 pcs.	241 x 110 x 14 mm	1

**Description**

Material (lens): Glass  
 Material (body): Metal (Zinc alloy)  
 Battery: 2 x AA 1,5 V (NOT included)  
 Packing: Black padded case

**HANDHELD MAGNIFIER 3X/5X/7X - WITH LED LIGHT**

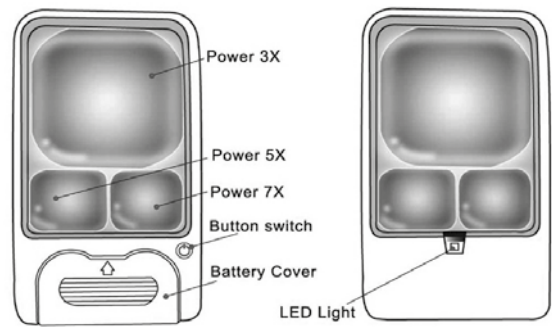

Part No.	Magnification	Lens diameter	# LED lights	dimensions	
HM50	3X/5X/7X	50x50/20x25	1	117x61x9 mm	1

**Description**

Material (body): ABS plastic  
 Battery: 2 x CR2032 (included)  
 Battery life: Approx. 40-50 hours

# 09.

## MACHINE ACCESSORIES

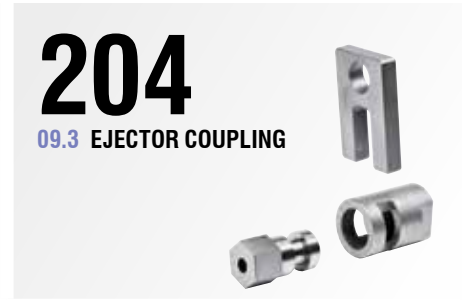
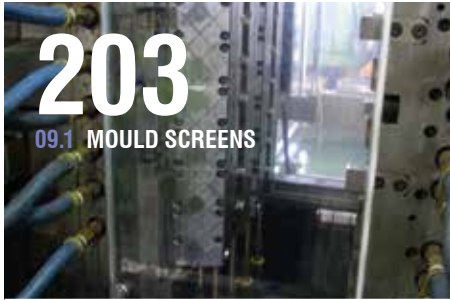

**MOULDSCREENS**



Part No.	Mould Height	Max Width	
SG-1	200 mm	550 mm	1 (set of 2 pcs)
SG-2	300 mm	550 mm	1 (set of 2 pcs)
SG-3	400 mm	550 mm	1 (set of 2 pcs)
SG-4	500 mm	550 mm	1 (set of 2 pcs)
SG-5	600 mm	550 mm	1 (set of 2 pcs)

**Description**

Prevent Plastic Parts scattering around the moulding machine with Scatterguard. The patented new design contains the Ejected Parts within the Mould Area whilst the roller blind action allows a completely unrestricted view of the Mould Face. Scatterguard allows easy access to the mould with the Ultra Low Profile Design meaning that the mould screens can be installed even when there are lots of water connectors on the side of the mould. Supplied as a kit Scatterguard is simply installed with Magnetic Anchors and is easily movable to other Moulding Machines.

- Ultra Low Profile Design
- Crystal Clear Mould Screen
- Reduce Scrap by Eliminating Contamination and Increase Profits
- Ideal for Cleanroom Applications

**MOLD-ALIGN® - A unique, affordable and easy to use tool that reveals pressure distribution between mould platens**

3 Easy Steps

1

**Mold-Align® comes on a roll**



2

**Place Mold-Align® between the two mold half surfaces**

MOLD-ALIGN® GOES HERE

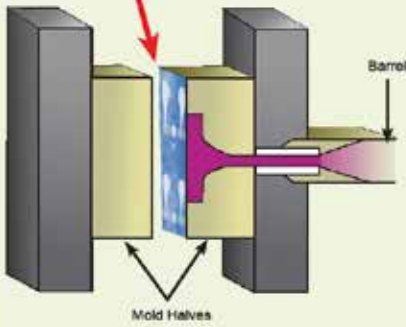

3

**Mold-Align® captures a permanent image of surface pressure distribution**



Part No.	Dimensions	
MA26-1	26,7 cm x 1 m. (Sheet)	1
MA26	26,7 cm x 15.25 m. (Roll)	1
MA76-1	76,2 cm x 1 m. (Sheet)	1
MA76	76,2 cm x 15.25 m. (Roll)	1

**Description**

**Specifications:**

Thickness 4 mils (0.1016 mm)  
 Usable Humidity Range 10-90% RH  
 Pressure Range 200 - 6,000 PSI (14 - 422 kg/cm<sup>2</sup>)  
 Temperature Limit 93°C

**Parting Line aligned and Uniform:**

One way to ensure proper mating of the tool halves at the parting line is simply by having a level moulding machine and parallel platens. Levelling a machine requires three machinist levels. If you have shorts and flash, you could have a mould or clamping alignment problem. This may not be the case if you are running a high-speed, thin-wall product—the problem may be simply not enough clamp force. To help establish whether flash stems from a mould or clamp alignment issue, check parting-line mating. In one typical check for uniform clamp pressure at the parting line, blueing agent applied to one mould half will transfer to the other if there is contact at the parting line, but it will not distinguish between low or high touch force. More detailed information can be obtained with Mold-Align® paper, which changes color relative to the amount of contact force. Mold-Align® is an extremely economical and practical solution for determining proper mould alignment. Mold-Align® is a self contained (single sheet) paper that is quickly implemented, requires no training, and reveals a high resolution image of pressure distribution and void spots between mould plates.

## EJECTOR COUPLINGS

### Description

The UKM is a mechanical ejector coupling for plastic injection moulding machines. Its function is to lock the ejector bars of the injection moulding tool.

- The coupling process "locking or unlocking" takes place in only seconds.
- Simple construction - easy to install
- Available with M10 – M12 and M16 thread.

### Material:

Steel Type: 1.2510

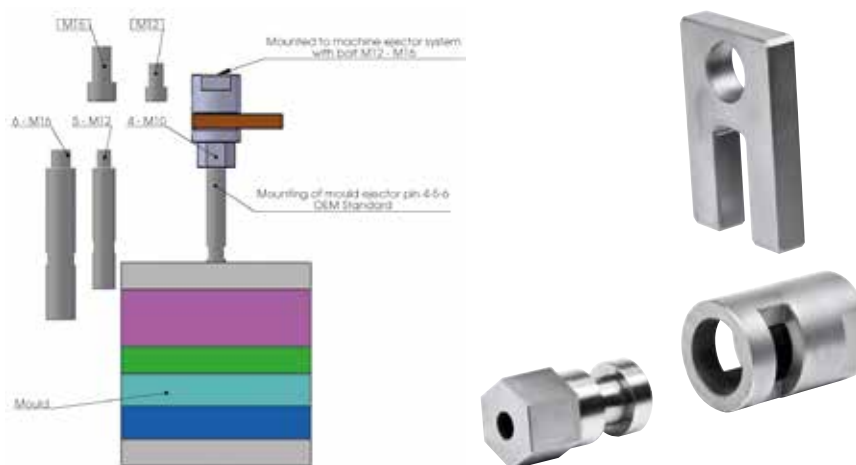

## CONNECTOR NIPPLE

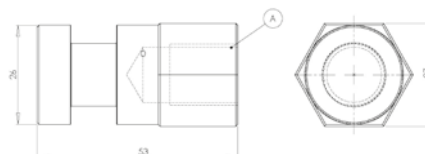

Part No.	A	
UKM10HAN	M10	1
UKM12HAN	M12	1
UKM16HAN	M16	1

## LOCKING SLIDE

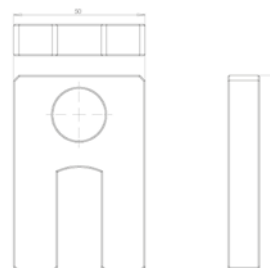

Part No.	SIZE	
UKKILE	ONE SIZE	1

## COUPLING

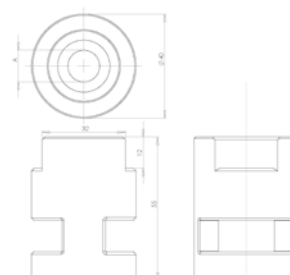

Part No.	A	
UKM12HUN	12	1
UKM16HUN	16	1



Speed up mould changes with the MPE Quick Connect Ejector Coupling that is designed to connect the mould ejector plate to the machine ejection system.

Depending on access inside the moulding machine the coupling may be operated manually or remotely by using compressed air. The coupling is released using air and will stay connected in the event of air failure.

The coupling is available in two different sizes to suit the machine size and can be adapted to a variety of ejector bar threads.

- Reduced Mould Changeover Time
- Safe to Use
- Quick and Efficient
- No tools required

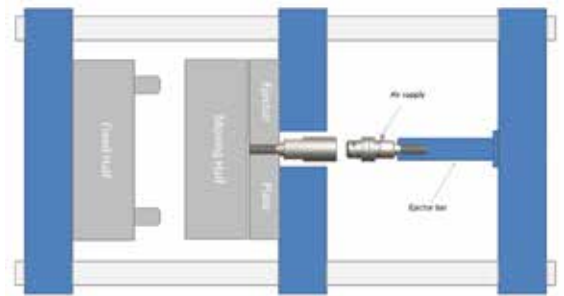

**COUPLING UNIT**

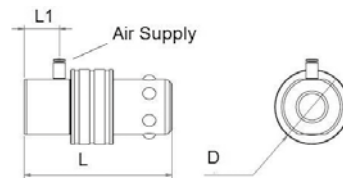

Part No.	Series	L1	L	D	Working pressure	Total length in locked position	Air Supply Thread	Female Thread	Ejector Force per coupler	
MPE-C-1	1"	18	58	27	Min. 4 bar / max 6 bar	101 mm	M5	M12	1500 kg	1
MPE-C-2	2"	23	97	49	Min. 6 bar / max 8 bar	175mm	M5	M20	6000 kg	1

**SOCKET UNIT**



Part No.	Series	L	D	Female Thread	Ejector Force per coupler	
MPE-S-1	1"	58	25	M12	1500 kg	1
MPE-S-2	2"	108	49	M20	6000 kg	1

**ADAPTOR**

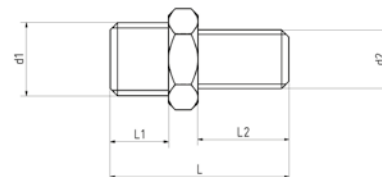

Part No.	Series	d1	d2	L1	L2	L	SW	
MPE-A-1-A	1"	M12x1,75	M12x1,75	10	20	35	19	1
MPE-A-1-B	1"	M12x1,75	3/8"-16	10	20	35	19	1
MPE-A-1-C	1"	M12x1,75	M16x2	10	20	35	19	1
MPE-A-2-B	2"	M20x2,5	M16x2	16	25	49	24	1
MPE-A-2-D	2"	M20x2,5	3/4"-10	16	25	49	24	1
MPE-A-2-E	2"	M20x2,5	M24x2,5	16	25	49	24	1

# EJECTOR COUPLINGS



Ideal for use with: Quick Mould Change systems and Two-stage Ejection

Designed to provide a quick method of attaching the ejector plate in your mould to the ejection system in your moulding machine. Provides positive ejector plate return while greatly reducing set-up time.

Perfectly suited for those moulding machines where the ejector plate on the machine is difficult to reach. Ideal when center ejection is desired, but impossible to "tie-in". Works with either hydraulic or mechanical ejection

Uses and Advantages:

- Quick and easy installation (even on existing moulds). Return of the ejector plate is assured.
- Part ejector plate is assured.
- Coupling is obtained in any position, disconnecting is after the ejector plate is fully returned.
- Fast acting up to 30 strokes/minute. No wearing parts.
- Can be used on all injection machines equipped with hydraulic or mechanical ejection.
- Set-up time can be greatly reduced.
- Reduce noise on machines with mechanical knockouts. Especially suited for injection machines that do not have easy access to the ejector plate.
- Allows for center ejection to be tied in.
- No Grease should be applied to these Products.

## Sequence of operation

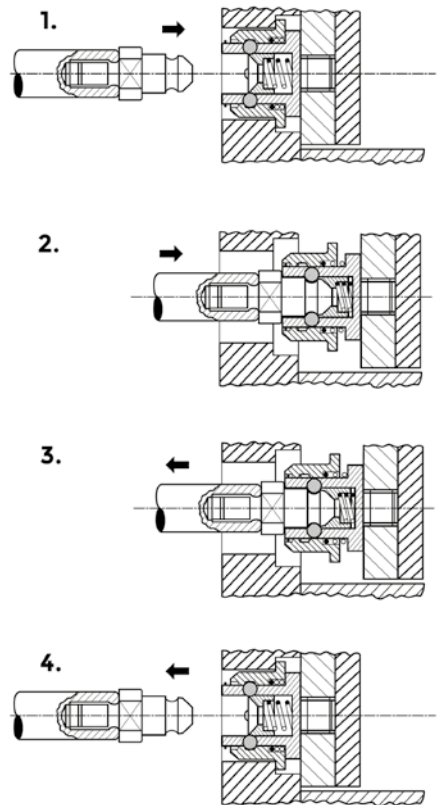

## EJECTOR COUPLING

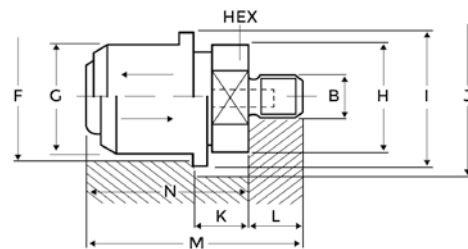



Part No.	B	F	G	H	I	J	K	L	M	Pull Force	Size	
EJC-F-1-1	M12X1,75	34	34	32	39	43	9	15	42,5	1500 kg	1	1
EJC-F-1-2	M16X1,5	34	34	32	39	43	9	15	42,5	1500 kg	1	1
EJC-F-1-3	M16X2	34	34	32	39	43	9	15	42,5	1500 kg	1	1
EJC-F-2-1	M16X1,5	40	40	38	48	53	13	15	52	2400 kg	2	1
EJC-F-2-2	M16X2	40	40	38	48	53	13	15	52	2400 kg	2	1
EJC-F-3-1	M16X1,5	58	58	56	65	70	17	18	68	3200 kg	3	1
EJC-F-3-2	M16X2	58	58	56	65	70	17	18	68	3200 kg	3	1
EJC-F-3-3	M18X1,5	58	58	56	65	70	17	18	68	3200 kg	3	1
EJC-F-3-4	M20X1,5	58	58	56	65	70	17	18	68	3200 kg	3	1
EJC-F-3-5	M20X2,5	58	58	56	65	70	17	18	68	3200 kg	3	1
EJC-F-3-6	M24X1,5	58	58	56	65	70	17	18	68	3200 kg	3	1
EJC-F-3-7	M27X1,5	58	58	56	65	70	17	18	68	3200 kg	3	1
EJC-F-3-8	M30X1,5	58	58	56	65	70	17	18	68	3200 kg	3	1

**Description**

Material: 1.7147 - 60 HRC

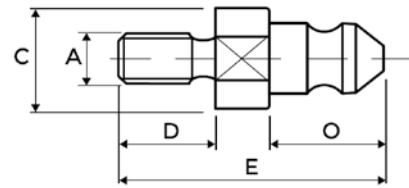
**EJECTOR NIPPLE**



Part No.	A	C	D	E	Pull Force	Size	
EJC-M-1-1	M10X1,5	22,8	20	45,5	1500 kg	1	1
EJC-M-1-2	M12X1,75	22,8	20	45,5	1500 kg	1	1
EJC-M-1-3	M14X2	22,8	20	45,5	1500 kg	1	1
EJC-M-1-4	M16X2	25,8	20	55	2400 kg	1	1
EJC-M-2-1	M10X1,5	25,8	20	55	2400 kg	2	1
EJC-M-2-2	M12X1,75	25,8	20	55	2400 kg	2	1
EJC-M-2-3	M14X2	25,8	20	55	2400 kg	2	1
EJC-M-2-4	M16X2	25,8	20	55	2400 kg	2	1
EJC-M-3-1	M16X2	35	25	68	3200 kg	3	1
EJC-M-3-2	M18X2,5	35	25	68	3200 kg	3	1
EJC-M-3-3	M20X2,5	35	25	68	3200 kg	3	1
EJC-M-3-4	M24X3	35	25	68	3200 kg	3	1
EJC-M-3-5	M27X3	35	25	68	3200 kg	3	1
EJC-M-3-6	M30X3,5	35	25	68	3200 kg	3	1

**Description**

Material: 1.7147 - 60 HRC

## MACHINE MOUNTS

### STANDARD MACHINE MOUNTS - SUPPLIED WITH ADJUSTING SCREWS



Part No.	Diameter	Load (kg)	Adjusting Screw	Height	
SMM01	80mm	200 kg	M12x1.25x120	38-50mm	1
SMM02	120mm	400 kg	M16x1.5x120	46-59mm	1
SMM03	160mm	1000 kg	M20x1.5x170	53-68mm	1
SMM04	160mm	2500 kg	M20x1.5x170	54-69mm	1
SMM05	200mm	3800 kg	M20x1.5x170	56-71mm	1

**Description**

Up to 15 mm ff Adjustment

Galvanised Steel Finish

Supplied Complete with Adjusting Screw





# LINEAR TRANSDUCERS

## TRANSDUCER WITHOUT ROD

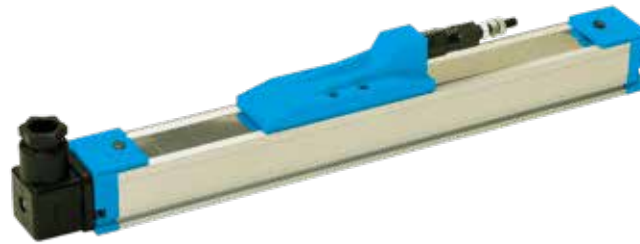

### Technical data

Measurement Stroke	100 to 1500 mm
Linearity	± %0,05
Repeatability	< 0,01 mm
Resolution	Infinite
Resistance	5 kOhm or 10 kOhm (20kOhm/1500 mm)
Resistance Tolerance	±%20
Load Resistance	100 kOhm min.
Recommended Cursor Current	< 1 μA
Permissible Applied Voltage	28VDC max.
Electrical Connections	4 pole hydraulic type connector
Displacement Speed	< 1,5 m/s
Mechanical Life	100 million cycles
Case Dimensions	33 mm x 33 mm
Case Material	Anodized aluminium
Mechanical Fixing	Variable brackets
IP Degree	IP 40 /If mounted upside down IP 53
Operating Temperature	-20°C ... +80°C
Storage Temperature	-30°C ... +90°C

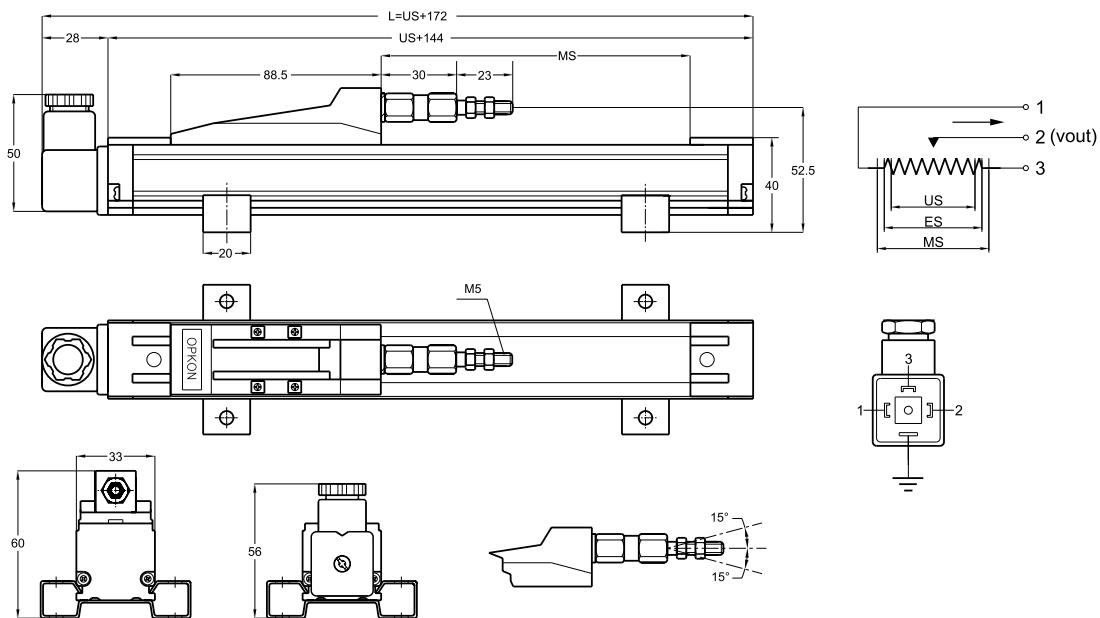

Part No.	US (usefull stroke)	MS (Mechanical stroke)	L (total length)	
MPH150	150	154	322	1
MPH200	200	204	372	1
MPH225	225	229	397	1
MPH300	300	304	472	1
MPH400	400	404	572	1
MPH500	500	504	672	1

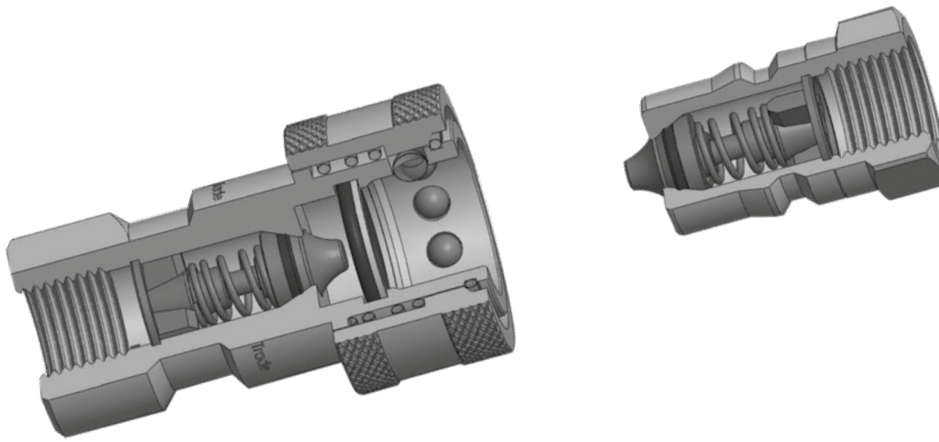

**ISO A COUPLERS**



Part No.	Thread size	Pressure Bar	
FISO-A14BSP	1/4" BSP	350	1
FISO-A38BSP	3/8" BSP	300	1
FISO-A12BSP	1/2" BSP	250	1
FISO-A34BSP	3/4" BSP	250	1
FISO-A100BSP	1" BSP	230	1

**Material:**  
Steel (plated)

**ISO A PLUGS**



Part No.	Thread size	Pressure Bar	
MISO-A14BSP	1/4" BSP	350	1
MISO-A38BSP	3/8" BSP	300	1
MISO-A12BSP	1/2" BSP	250	1
MISO-A34BSP	3/4" BSP	250	1
MISO-A100BSP	1" BSP	230	1

**ISO B COUPLERS**



Part No.	Thread size	Pressure Bar	
FISO-B14BSP	1/4" BSP	350	1
FISO-B38BSP	3/8" BSP	300	1
FISO-B12BSP	1/2" BSP	250	1

**Material:**  
Steel (plated)

**ISO B PLUGS**



Part No.	Thread size	Pressure Bar	
MISO-B14BSP	1/4" BSP	350	1
MISO-B38BSP	3/8" BSP	300	1
MISO-B12BSP	1/2" BSP	250	1

# 10.

## MOULD CLAMPING



**POWER SLIDING CLAMP**

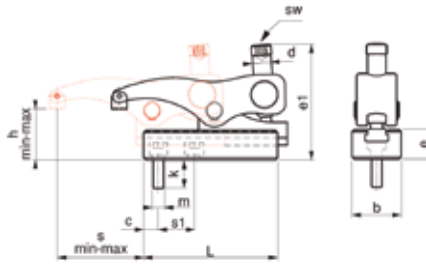

Part No.	Thread Size	h-Min	h-Max	s	e1	d	sw	L	e	b	c	K	Clamping force Kgf	Screw fastening torque (Nm)	
SC-10-10	M10	0	50	12-66	100	M14	8	104	35,5	38	13	20	1600	55	1
SC-10-12	M12	0	50	12-66	100	M14	8	104	35,5	38	13	20	1600	55	1
SC-20-12	M12	0	60	15-83	113	M18	10	128	38	48	16	22	2000	100	1
SC-20-16	M16	0	60	15-83	113	M18	10	128	38	48	16	26	2000	100	1
SC-25-16	M16	0	62	18-96	125	M20	12	140	42	55	18	26	2500	150	1
SC-25-18	M18	0	62	18-96	125	M20	12	140	42	55	18	30	2500	150	1
SC-25-20	M20	0	62	18-96	125	M20	12	140	42	55	18	30	2500	150	1
SC-30-20	M20	20	80	22-95	175	M24	12	178	55	74	24	34	5500	200	1
SC-30-22	M22	20	80	22-95	175	M24	12	178	55	74	24	38	5500	200	1
SC-30-24	M24	20	80	22-95	175	M24	12	178	55	74	24	44	5500	200	1
SC-30-30	M30	20	80	22-95	175	M24	12	178	55	74	24	55	5500	200	1

**Description**

- Perfect for Injection Mould Clamping
- For use with threaded or T-Slot Platens
- Ability to be fixed in various positions by sliding
- Suitable for different clamping heights using the adjustable bolt
- It provides rapid and easy connection due to it's practical structure

**CLAMP CALCULATION GUIDE**

**Power Clamp For Injection Moulding**

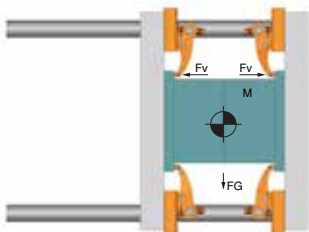

**Formula Calculator**

$$\frac{M \times FG}{1000} = \text{kN} \quad \frac{2500 \times 9.81}{1000} = 24.52 \text{ kN}$$

$$\frac{\text{kN}}{\mu} = \text{Result} \quad \frac{24.52}{0.14} = 175.14 \text{ kN}$$

$$\frac{\text{Result}}{Fv} = \text{Number of Clamp} \quad \frac{175.14 \text{ kN}}{25 \text{ kN}} = 7 \text{ Clamp (use 8 pcs)}$$

**Power Clamp For Press Moulding**

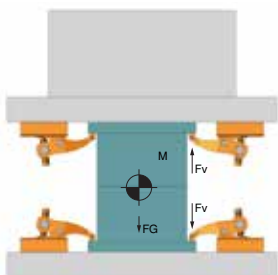

**Formula Calculator**

$$\frac{M \times FG}{1000} = \text{kN} \quad \frac{5000 \times 9.81}{1000} = 49.050 \text{ kN}$$

$$\frac{\text{kN}}{\mu} = \text{Result} \quad \frac{49.05}{0.14} = 350.35 \text{ kN}$$

$$\frac{\text{Result}}{Fv} = \text{Number of Clamp} \quad \frac{210.21 \text{ kN (upper)}}{25 \text{ kN}} = 8 \text{ Number of Clamp}$$

$$\frac{\text{Result}}{Fv} = \text{Number of Clamp} \quad \frac{140.14 \text{ kN (lower)}}{25 \text{ kN}} = 5.6 \text{ Clamp (use 6 pcs)}$$

**Force Diagram**

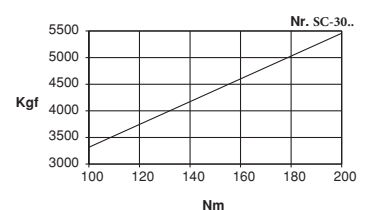
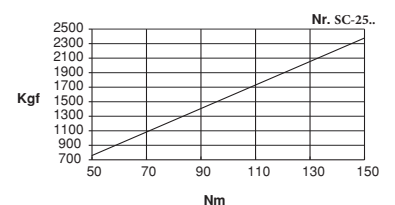
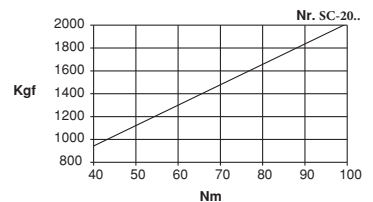
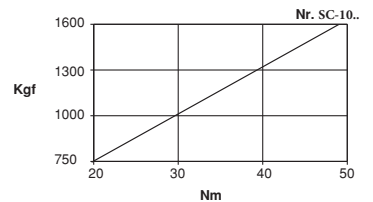

## STANDARD CLAMPS

### STRAIGHT CLAMP WITH SUPPORT HOLE - SUPPLIED WITHOUT ADJUSTING SCREW

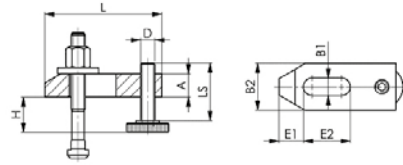

Part No.	Nut	DIN6314 B1xL	D	A	B2	E1	E2	
1330-11x80	10	11x80	M10	15	30	15	30	1
1330-14x100	12+14	14x100	M12	20	40	21	40	1
1330-14x125	12+14	14x125	M12	20	40	21	50	1
1330-18x125	16+18	18x125	M16	25	50	26	45	1
1330-18x160	16+18	18x160	M16	25	50	26	65	1
1330-22x160	20+22	22x160	M20	30	60	30	60	1
1330-22x200	20+22	22x200	M20	30	60	30	80	1
1330-26x160	24+26	26x160	M24	30	70	35	60	1
1330-26x200	24+26	26x200	M24	35	70	35	80	1
1330-26x250	24+26	26x250	M24	35	70	35	100	1
1330-26x315	24+26	26x315	M24	40	70	35	130	1
1330-33x315	30+33	33x315	M24	50	80	45	130	1
1330-43x400	36+43	43x400	M30	60	100	100	150	1

### ADJUSTING SCREW

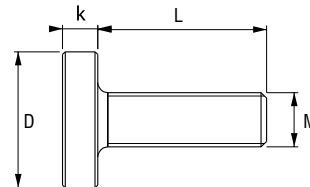

Part No.	M	L	D	K	
1490-10x42	M10	42	30	8	1
1490-12x50	M12	50	36	10	1
1490-12x95	M12	95	36	10	1
1490-16x62	M16	62	45	13	1
1490-16x97	M16	97	45	13	1
1490-16x117	M16	117	45	13	1
1490-20x62	M20	62	50	13	1
1490-20x97	M20	97	50	13	1
1490-20x117	M20	117	50	13	1
1490-24x81	M24	81	50	14	1
1490-24x116	M24	116	50	14	1
1490-30x180	M30	18	70	24	1

#### Description

Material: Ck45 DIN

Black Coating

**HEXAGON NUT**

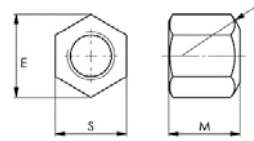

Part No.	Size	E	M	R	S	
6330B-6	M6	11,5	9	9	10	1
6330B-8	M8	15	12	12	13	1
6330B-10	M10	19,6	15	15	17	1
6330B-12	M12	21,9	18	17	19	1
6330B-14	M14	25,4	21	20	22	1
6330B-16	M16	27,7	24	22	24	1
6330B-18	M18	31,2	27	24	27	1
6330B-20	M20	34,6	30	27	30	1
6330B-22	M22	36,9	33	30	32	1
6330B-24	M24	41,5	36	32	36	1
6330B-30	M30	53,1	45	41	46	1
6330B-36	M36	63,5	54	50	55	1

**Description**  
 Hexagon Nut DIN 6330B  
 Material: Ck45 DIN  
 Hardness: 30-32 HRC  
 Black Coating

**THICK WASHER**

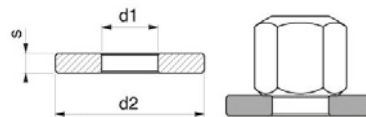

Part No.	d1	Thread to fit	d2	s	
KP-M6	6,4	M6	17	3	1
KP-M8	8,4	M8	23	4	1
KP-M10	10,5	M10	28	4	1
KP-M12	13	M12	35	5	1
KP-M14	15	M14	40	5	1
KP-M16	17	M16	45	6	1
KP-M18	19	M18	45	6	1
KP-M20	21	M20	50	6	1
KP-M22	23	M22	50	8	1
KP-M24	25	M24	60	8	1
KP-M30	31	M30	68	10	1

**Description**  
 Ideal for Mould Clamping

# STANDARD CLAMPS

## STRAIGHT STUD

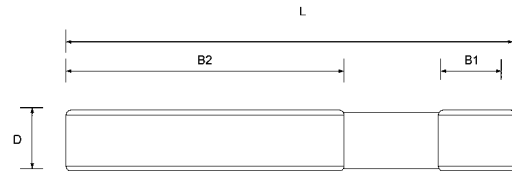

Part No.	D x L	B1	B2	
6379-8x40	M 8x 40	11	20	1
6379-8x63	M 8x 63	11	40	1
6379-8x80	M 8x 80	11	50	1
6379-8x100	M 8x100	11	63	1
6379-8x125	M 8x125	11	75	1
6379-8x160	M 8x160	11	100	1
6379-10x50	M10x 50	13	25	1
6379-10x80	M10x 80	13	50	1
6379-10x100	M10x100	13	75	1
6379-10x125	M10x125	13	75	1
6379-10x160	M10x160	13	100	1
6379-10x200	M10x200	13	125	1
6379-12x50	M12x 50	15	25	1
6379-12x63	M12x 63	15	32	1
6379-12x80	M12x 80	15	50	1
6379-12x100	M12x100	15	63	1
6379-12x125	M12x125	15	75	1
6379-12x160	M12x160	15	100	1
6379-12x200	M12x200	15	125	1
6379-14x63	M14x 63	17	32	1
6379-14x80	M14x80	17	50	1
6379-14x100	M14x100	17	63	1
6379-14x125	M14x125	17	75	1
6379-14x160	M14x160	17	100	1
6379-14x200	M14x200	17	125	1
6379-14x250	M14x250	17	160	1
6379-16x63	M16x 63	19	32	1
6379-16x80	M16x 80	19	50	1
6379-16x100	M16x100	19	63	1
6379-16x125	M16x125	19	75	1
6379-16x160	M16x160	19	100	1
6379-16x200	M16x200	19	125	1
6379-16x250	M16x250	19	160	1
6379-16x315	M16x315	19	180	1
6379-16x500	M16x500	19	315	1
6379-18x80	M18x 80	23	50	1
6379-18x125	M18x125	23	75	1
6379-18x160	M18x160	23	100	1
6379-18x200	M18x200	23	125	1
6379-18x250	M18x250	23	150	1

Part No.	D x L	B1	B2	
6379-18x315	M18x315	23	180	1
6379-20x80	M20x 80	27	32	1
6379-20x125	M20x125	27	70	1
6379-20x160	M20x160	27	100	1
6379-20x200	M20x200	27	125	1
6379-20x250	M20x250	27	160	1
6379-20x315	M20x315	27	200	1
6379-20x400	M20x400	27	250	1
6379-20x500	M20x500	27	315	1
6379-22x100	M22x100	31	45	1
6379-22x160	M22x160	31	100	1
6379-22x200	M22x200	31	125	1
6379-22x250	M22x250	31	160	1
6379-22x315	M22x315	31	180	1
6379-22x400	M22x400	31	250	1
6379-24x100	M24x100	35	45	1
6379-24x125	M24x125	35	70	1
6379-24x160	M24x160	35	100	1
6379-24x200	M24x200	35	125	1
6379-24x250	M24x250	35	160	1
6379-24x315	M24x315	35	200	1
6379-24x400	M24x400	35	250	1
6379-24x500	M24x500	35	315	1
6379-24x630	M24x630	35	315	1
6379-30x125	M30x125	43	56	1
6379-30x200	M30x200	43	125	1
6379-30x315	M30x315	43	200	1
6379-30x500	M30x500	43	315	1
6379-30x700	M30x700	43	400	1
6379-30x1000	M30x1000	43	400	1
6379-36x160	M36x160	51	80	1
6379-36x200	M36x200	51	125	1
6379-36x250	M36x250	51	160	1
6379-36x315	M36x315	51	200	1
6379-36x400	M36x400	51	250	1
6379-36x500	M36x500	51	315	1
6379-36x700	M36x700	51	400	1
6379-42x315	M42x315	59	200	1
6379-42x400	M42x400	59	250	1
6379-42x500	M42x500	59	315	1

**Description**  
 Material: 41 Cr 4 DIN  
 Quality 10.9  
 Black Coating



**T-NUT**

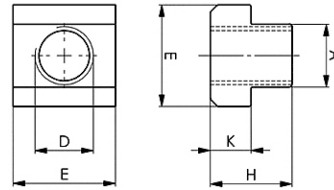

Part No.	D x Nut	A	E	H	K	
508-6x8	M 6x 8	7,7	13	10	6	1
508-8x10	M 8x10	9,7	15	12	6	1
508-8x12	M 8x12	11,7	18	14	7	1
508-10x12	M10x12	11,7	18	14	7	1
508-8x14	M 8x14	13,7	22	16	8	1
508-10x14	M10x14	13,7	22	16	8	1
508-12x14	M12x14	13,7	22	16	8	1
508-8x16	M 8x16	15,7	25	18	9	1
508-10x16	M10x16	15,7	25	18	9	1
508-12x16	M12x16	15,7	25	18	9	1
508-14x16	M14x16	15,7	25	18	9	1
508-8x18	M 8x18	17,7	28	20	10	1
508-10x18	M10x18	17,7	28	20	10	1
508-12x18	M12x18	17,7	28	20	10	1
508-14x18	M14x18	17,7	28	20	10	1
508-16x18	M16x18	17,7	28	20	10	1
508-16x20	M16x20	19,7	32	24	12	1
508-18x20	M18x20	19,7	32	24	12	1
508-16x22	M16x22	21,7	35	28	14	1
508-18x22	M18x22	21,7	35	28	14	1
508-20x22	M20x22	21,7	35	28	14	1
508-16x24	M16x24	23,7	40	32	16	1
508-20x24	M20x24	23,7	40	32	16	1
508-22x24	M22x24	23,7	40	32	16	1
508-16x28	M16x28	27,7	44	36	18	1
508-20x28	M20x28	27,7	44	36	18	1
508-22x28	M22x28	27,7	44	36	18	1
508-24x28	M24x28	27,7	44	36	18	1
508-24x36	M24x36	35,6	54	44	22	1
508-30x36	M30x36	35,6	54	44	22	1

**Description**  
 T-Clamp DIN 508  
 Material: Ck45 DIN  
 Hardness: 30-32 HRC  
 Black Coating

# 11.

## LIFTING

### 219

11.1 EYEBOLTS



### 220

11.2 SWIVEL LIFTING RINGS





### 222

11.3 DOUBLE SWIVEL RING & SHACKLES

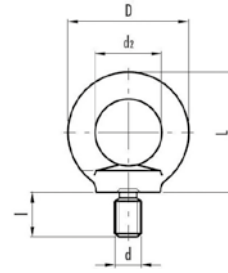

**LIFTING EYEBOLTS - ZINC ELECTROPLATED DIN 580**



Part No.	d	l	D	d2	L	WLL	
EBGM8	M8	13	36	20	36	140kg	1
EBGM10	M10	17	45	25	45	230kg	1
EBGM12	M12	20	54	30	53	340kg	1
EBGM16	M16	27	63	35	62	700kg	1
EBGM20	M20	30	72	40	71	1200kg	1
EBGM24	M24	36	90	50	90	1800kg	1
EBGM30	M30	45	108	60	109	3600kg	1
EBGM36	M36	54	126	70	128	5100kg	1
EBGM42	M42	63	144	80	147	7000kg	1
EBGM48	M48	68	160	90	168	8600kg	1

# SWIVEL LIFTING RINGS

## SWIVEL EYEBOLTS

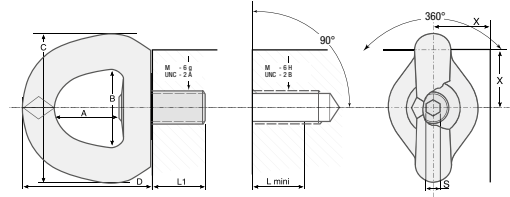

Part	SF 5:1 WLL (t)	SF 4:1 WLL (t)	Diameter	L1	N.m	X	S	A	B	C	D	Weight kg	
SEBM8	0,4	0,5	M8(x1,25)	14	6	20	4	30	34	60	57	0,24	1
SEBM10	0,5	0,7	M10(x1,5)	17	10	20	4	30	34	60	57	0,24	1
SEBM12	0,8	0,9	M12(x1,75)	21	15	20	4	30	34	60	57	0,24	1
SEBM16	1,4	1,8	M16(x2)	27	50	35	8	38	45	90	78	0,8	1
SEBM20	2	2,7	M20(x2,5)	30	100	35	8	38	45	90	78	0,8	1
SEBM24	3,2	3,8	M24(x3)	36	160	50	14	58	70	134	115	2,6	1
SEBM30	5,5	6,3	M30(x3,5)	45	250	50	14	58	70	134	115	2,7	1
SEBM36	9	11	M36(x4)	54	320	70	14	88	94	190	166	8	1
SEBM42	12	15	M42(x4,5)	63	400	70	14	88	94	190	166	8,1	1
SEBM48	15	16	M48(x5)	68	600	70	19	88	94	190	166	9	1

## GRADE 8 KEY EYE POINT - METRIC THREAD

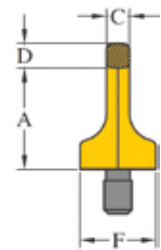
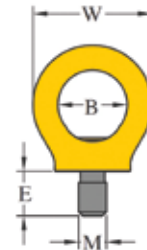

Part No.	W.L.L. (t) x (z)	Bolt Size	A	B	C	D	E	F	W	S	Mass Kg	
KEP-M10	0.40 (1)	M10 x 1.50 x 20	36	25	8	11	15	25	44	15	0.1	1
KEP-M12	0.75 (2)	M12 x 1.75 x 28	42	30	10	13	18	33	52	18	0.2	1
KEP-M16	1.50 (4)	M16 x 2.00 x 30	51	35	14	13	24	35	61	24	0.3	1
KEP-M20	2.30 (6)	M20 x 2.00 x 30	57	40	16	17	30	44	70	30	0.6	1
KEP-M24	3.20 (8)	M24 x 3.00 x 48	70	48	19	21	36	52	84	36	1.0	1
KEP-M30	4.50 (12)	M30 x 3.50 x 55	86	60	24	26	45	62	108	45	1.8	1
KEP-M36	7.00 (16)	M36 x 4.00 x 64	103	72	29	32	54	78	130	54	3.2	1
KEP-M42	9.00 (24)	M42 x 4.50 x 85	120	82	34	38	63	88	150	63	5.0	1
KEP-M48	12.00 (32)	M48 x 5.00 x 96	137	94	38	43	72	104	168	72	7.6	1

Grade 8 forged lifting components are manufactured from alloy steel in accordance with EN1677. All forged components are individually magnaflux crack detected after heat treatment, they are then individually proof load tested to 2.5 times working load limit in accordance with EN1677. Only components fully compliant with all aspects of EN1677 can be used in chain slings certified to EN818-4. The William Hackett Grade 8 lifting components are suitable for use in a temperature range of -40°C up to 200°C without reduction in working load limit. The Key Eye Point has a Design Factor of 4:1 and the Bolt is in a Black Finish.

### Uses

- 21st century successor to the eye bolt
- Design features make the Key Eye Point resistant to side loading failure and accidental unscrewing

### Load directions



- Nominal WLL -

Vertical load  
- Straight Pull -  
(z)-values

**SAFETY RING BOLTS - ROTATABLE**

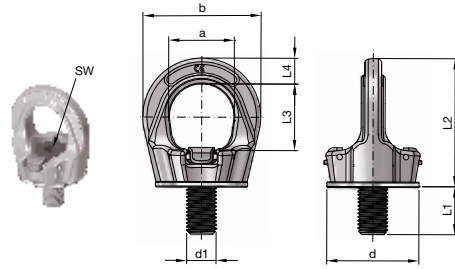

Part No.	d1	Load capacity	a	b	d	L1	L2	L3	L4	SW	kg	
RBRM8	M8	300	25	45	35	15	53	27	10	6	0,17	1
RBRM10	M10	500	25	45	35	15	53	27	10	6	0,18	1
RBRM12	M12	700	30	55	43	20	63	32	12	8	0,29	1
RBRM16	M16	1500	35	64	50	25	70	36	14	10	0,45	1
RBRM20	M20	2000	40	69	54	30	78	41	16	12	0,58	1
RBRM24	M24	3000	50	86	69	35	97	50	18	14	1,10	1
RBRM30	M30	4000	60	110	90	45	114	60	25	17	2,20	1
RBRM36	M36	7000	70	132	108	55	136	70	31	19	3,90	1
RBRM42	M42	9000	80	152	126	65	153	76	36	22	5,80	1
RBRM48	M48	12000	95	179	148	75	179	95	42	24	8,90	1

**Safety ring bolts, rotatable**

Mounting and safety notices

**Tool-free assembly and disassembly**

The latch in pos.1 does not have any contact with the screw (picture 1)

The latch in pos. 2 has contact with the screw (picture 2)

**Permissible usage**

Load capacity according to the inspection certificate table of WLL in the shown directions of pull (picture 3).

- Adjust the lifting point in the permitted load direction before loading.
- For a durable fastening going up with a specified tightness.
- Loadable with a 4-fold safety under break in all directions.

**Non permissible usage**

Make sure when choosing the assembly that improper loading can not arise e.g. if:

- The direction of pull is obstructed.
- Direction of pull is not in the foreseen area (picture 4).
- Loading ring rests against edges or loads.

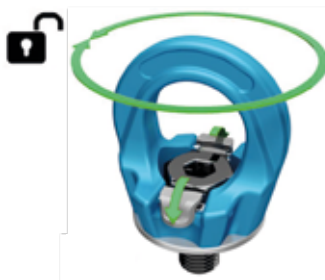

Picture 1



Picture 2



Picture 3

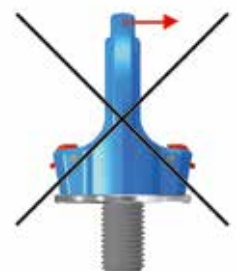

Picture 4

# DOUBLE SWIVEL RING & SHACKLES

## DOUBLE SWIVEL RING

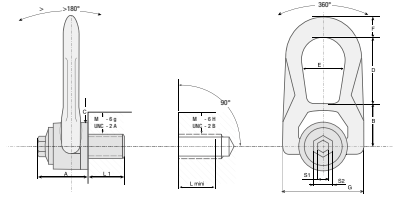

Part No.	SF 5:1 WLL (t)	SF 4:1 WLL (t)	Diameter	Ø	P	L1	N.m	S1	S2	A	B	C	D	E	F	G	Weight	
DSRM5	0,07	0,1	M5 (x0,8)			15	3	4		33	30	30	38	27	14	53	0,3 kg	1
DSRM6	0,15	0,2	M6 (x1)			15	4	5		33	30	30	38	27	14	53	0,3 kg	1
DSRM8	0,4	0,5	M8 (x1,25)			14	6	8	16	33	30	30	38	27	14	53	0,3 kg	1
DSRM10	0,7	0,9	M10 (x1,50)			17	10	8	16	33	30	30	38	27	14	53	0,3 kg	1
DSRM12	1,05	1,3	M12 (x1,75)			21	15	8	16	33	30	30	38	27	14	53	0,3 kg	1
DSRM14	1,4	1,8	M14 (x2)			23	30	8	20	45	42	45	54	38	17	76	0,9 kg	1
DSRM16	2	2,3	M16 (x2)			27	50	8	20	45	42	45	54	38	17	76	0,9 kg	1
DSRM18	2,3	2,3	M18 (x2,5)			27	70	8	20	45	42	45	54	38	17	76	0,9 kg	1
DSRM20	2,5	2,5	M20 (x2,5)			30	100	8	20	45	42	45	54	38	17	76	0,9 kg	1
DSRM22	3,5	4,5	M22 (x2,5)			33	120	14	24	62	55	60	83	55	25	117	2,6 kg	1
DSRM24	4,4	5,5	M24 (x3)			36	160	14	24	62	55	60	83	55	25	117	2,6 kg	1
DSRM27	5,7	6	M27 (x3)			40	200	14	24	62	55	60	83	55	25	117	2,7 kg	1
DSRM30	6	6,3	M30 (x3,5)			45	250	14	24	62	55	60	83	55	25	117	2,7 kg	1

### Description

Double Swivel Ring. Double articulation allows it to line up perfectly with the sling  
 Two ways of tightening: either by open-ended spanner or by Allen key  
 From M4 to M30 as standard; from 0,05t to 6,3t.

## DOUBLE SWIVEL SHACKLE

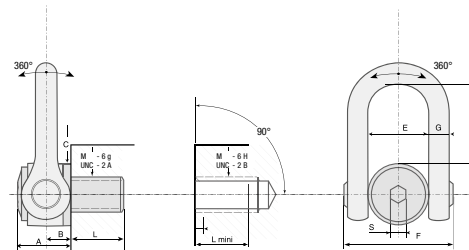



Part No.	SF 5:1 WLL (t)	SF 4:1 WLL (t)	Diameter	L1	N.m	S	A	B	C	D	E	F	G	Weight	
DSSM30	7,7	8,5	M30 (x3,5)	45	250	19	61	31	70	104	73	145	29	5,5 kg	1
DSSM33	8,5	10,5	M33 (x3,5)	50	250	19	61	31	70	104	73	145	29	5,5 kg	1
DSSM36	11	12	M36 (x4)	54	320	19	61	31	70	104	73	145	29	5,5 kg	1
DSSM36x3	11	12	M36 (x3)	54	320	19	61	31	70	104	73	145	29	5,5 kg	1
DSSM39	12	14	M39 (x4)	58	320	19	61	31	70	104	73	145	29	5,7 kg	1
DSSM42	13	15	M42 (x4,5)	63	400	19	61	31	70	104	73	145	29	5,8 kg	1
DSSM42x3	13	15	M42 (x3)	63	400	19	61	31	70	104	73	145	29	5,8 kg	1
DSSM45	14	16	M45 (x4,5)	63	400	19	61	31	70	104	73	145	29	5,7 kg	1
DSSM48	17	20	M48 (x5)	68	600	19	79	38	90	125	91	184	33	11 kg	1
DSSM48x3	17	20	M48 (x3)	68	600	19	79	38	90	125	91	184	33	11 kg	1
DSSM48x4	17	20	M48 (x4)	68	600	19	79	38	90	125	91	184	33	11 kg	1
DSSM52	19	20	M52 (x5)	68	600	19	79	38	90	125	91	184	33	11,2 kg	1
DSSM56	22	25	M56 (x5,5)	78	600	19	79	38	90	125	91	184	33	11,3 kg	1
DSSM56x4	22	25	M56 (x4)	78	600	19	79	38	90	125	91	184	33	11,4 kg	1
DSSM64	25	32,1	M64 (x6)	90	600	19	79	38	95	125	91	184	33	12,2 kg	1
DSSM64x4	25	32,1	M64 (x4)	90	600	19	79	38	95	125	91	184	33	12,2 kg	1

### Description

Double Swivel Shackle  
 Double articulation allows it to line up perfectly with the sling.  
 From M30 to M64 as standard; for loads from 7,3t. to 32,1 t.

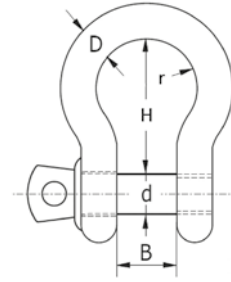
**ALLOY STEEL BOW SHACKLES - GALVANISED**



Part No.	Dim	B	d	H	r	WLL	
ASBSG11	3/8" x 7/16"	17mm	11mm	37mm	26mm	1000kg	1
ASBSG13	7/16" x 1/2"	18mm	13mm	43mm	29mm	1500kg	1
ASBSG16	1/2" x 5/8"	21mm	16mm	48mm	33mm	2000kg	1
ASBSG19	5/8" x 3/4"	27mm	19mm	60mm	43mm	3250kg	1
ASBSG22	3/4" x 7/8"	32mm	22mm	71mm	51mm	4750kg	1
ASBSG25	7/8" x 1"	37mm	25mm	84mm	58mm	6500kg	1
ASBSG28	1" x 1 1/8"	43mm	28mm	95mm	68mm	8500kg	1
ASBSG32	1 1/8" x 1 1/4"	46mm	32mm	104mm	75mm	9500kg	1
ASBSG35	1 1/4" x 1 3/8"	52mm	36mm	119mm	82mm	12000kg	1

# 12.

## MOULD COMPONENTS

### 225

12.1 EJECTOR PINS



### 230

12.2 SLEEVE EJECTORS



### 231

12.3 FLAT EJECTORS



### 232

12.4 CORE PINS



### 233

12.4 DOWEL PINS



### 235

12.5 ANGLE GUIDE PINS



### 236

12.7 SLIDE HOLDING DEVICES



### 238

12.8 SOCKET HEAD CAP SCREWS



### 239

12.9 SHOULDER SCREWS



### 240

12.11 SPRING PLUNGERS



### 241

12.12 ISO SPRINGS



### 244

12.13 MOULD CYCLE COUNTER





**EJECTOR PINS, DIN 1530, TYPE AH - HARDENED**

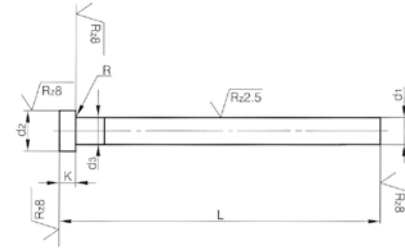

d1 g6	d2 0 -0,2	k 0 -0,05	R +0,2 0	d3	L 0/+2						
					100	125	160	200	250	315	400
1,5	3	1,5	0,2	d1 + 0,03	•	•	•	•			
1,6					•	•	•	•			
2,0	4	2			•	•	•	•	•	•	
2,2					•	•	•	•	•	•	
2,5	5		0,3		•	•	•	•	•	•	
2,7					•	•	•	•	•	•	
3,0	6	3			•	•	•	•	•	•	•
3,2					•	•	•	•	•	•	
3,5	7				•	•	•	•	•	•	
3,7					•	•	•	•	•	•	
4,0	8				•	•	•	•	•	•	•
4,2					•	•	•	•	•	•	•
4,5					•	•	•	•	•	•	•
4,7					•	•	•	•	•	•	•
5,0	10				•	•	•	•	•	•	•
5,2					•	•	•	•	•	•	•
5,5					•	•	•	•	•	•	•
6,0	12	5	0,5		•	•	•	•	•	•	•
6,2					•	•	•	•	•	•	•
6,5					•	•	•	•	•	•	•
7,0					•	•	•	•	•	•	•
8,0	14				•	•	•	•	•	•	•
8,2				d1 + 0,04	•	•	•	•	•	•	•
8,5					•	•	•	•	•	•	•
9,0					•	•	•	•	•	•	•
10,0					•	•	•	•	•	•	•
10,2					•	•	•	•	•	•	•
10,5					•	•	•	•	•	•	•
11,0					•	•	•	•	•	•	•
12,0	20	7	0,8		•	•	•	•	•	•	•
12,2					•	•	•	•	•	•	•
12,5					•	•	•	•	•	•	•
14,0	22				•	•	•	•	•	•	•
16,0					•	•	•	•	•	•	•
18,0	24			d1 + 0,07	•	•	•	•	•	•	•
20,0	26	8	1,0		•	•	•	•	•	•	•

**Description**

Surface: Hardened and Polished  
 Material: 1.2516  
 Hardness: 60 ± 2 HRC. Head 45 ± 5 HRC.

**Order example**

UDSAH+d1+L ex. UDSA4160 (4x160 mm)

# EJECTOR PINS

## EJECTOR PINS, DIN 6751, TYPE AB - NITRIDED

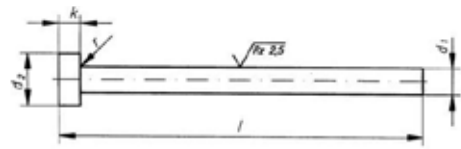

$$\sqrt{Rz 6} \quad (\sqrt{Rz 25})$$

d1 g6	d2 -0,2	k -0,05	R	d3	L 0/+2										
					100	125	160	200	250	315	400	500	630	800	1000
1,5	3	1,5	0,2	d <sub>1</sub> + 0,03	•	•	•	•							
2,0	4	2			•	•	•	•	•						
2,2			0,3		•	•	•	•	•						
2,5	5	3			•	•	•	•	•	•					
3,0	6				•	•	•	•	•	•	•				
3,2					•	•	•	•	•	•	•	•			
3,5	7				•	•	•	•	•	•	•	•			
3,7					•	•	•	•	•	•	•	•			
4,0	8				•	•	•	•	•	•	•	•	•		
4,2					•	•	•	•	•	•	•	•	•		
4,5					•	•	•	•	•	•	•	•	•		
5,0	10				•	•	•	•	•	•	•	•	•	•	
5,2					•	•	•	•	•	•	•	•	•		
6,0	12	5	0,5		•	•	•	•	•	•	•	•	•	•	
6,2					•	•	•	•	•	•	•	•	•		
8,0	14				•	•	•	•	•	•	•	•	•	•	•
8,2				d <sub>1</sub> + 0,04	•	•	•	•	•	•	•	•	•		
10,0	16				•	•	•	•	•	•	•	•	•	•	•
10,2					•	•	•	•	•	•	•	•	•		
11,0					•	•	•	•	•	•	•	•	•		
12,0	20	7	0,8		•	•	•	•	•	•	•	•	•	•	•
12,2					•	•	•	•	•	•	•	•	•		
12,5					•	•	•	•	•	•	•	•	•		
14,0	22				•	•	•	•	•	•	•	•	•	•	•
16,0					•	•	•	•	•	•	•	•	•	•	•
20,0	26	8	1	d <sub>1</sub> + 0,1		•	•	•	•	•	•	•	•	•	•
25,0	32	10					•	•	•	•	•	•	•	•	•
32,0	40						•	•	•	•	•	•	•	•	•

**Description**

Surface: Nitrided and Polished  
 Material: 1.2344  
 Hardness: 65 ± 2 HRC. Head 45 ± 5 HRC.

**Order example**

UDSAB+d1+L ex. UDSAB4160 (4x160 mm)

**EJECTOR PINS, DIN 1530, TYPE AN - NITRIDED**

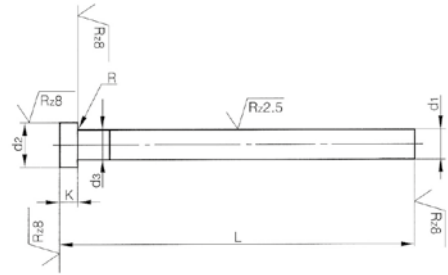

d1 g6	d2 -0,2	k -0,05	R	d3	L 0/+2											
					100	125	160	200	250	315	400	500	630	800	1000	
1,5	3	1,5	0,2	d <sub>1</sub> + 0,03	•	•	•	•								
2,0	4	2			•	•	•	•	•							
2,2			0,3		•	•	•	•								
2,5	5	3			•	•	•	•	•							
3,0	6				•	•	•	•	•							
3,2					•	•	•	•	•	•						
3,5	7				•	•	•	•	•	•						
3,7					•	•	•	•	•	•						
4,0	8				•	•	•	•	•	•						
4,2					•	•	•	•	•	•						
4,5					•	•	•	•	•	•						
5,0	10				•	•	•	•	•	•						
5,2					•	•	•	•	•	•						
6,0	12	5	0,5		•	•	•	•	•	•						
6,2					•	•	•	•	•	•						
8,0	14				•	•	•	•	•	•						
8,2				d <sub>1</sub> + 0,04	•	•	•	•	•	•						
10,0	16				•	•	•	•	•	•						
10,2					•	•	•	•	•	•						
11,0					•	•	•	•	•	•						
12,0	20	7	0,8		•	•	•	•	•	•						
12,2					•	•	•	•	•	•						
12,5					•	•	•	•	•	•						
14,0	22				•	•	•	•	•	•						
16,0					•	•	•	•	•	•						
20,0	26	8	1	d <sub>1</sub> + 0,1		•	•	•	•	•						
25,0	32	10					•	•	•	•						
32,0	40							•	•	•						

**Description**

Surface: Bath Nitrided  
 Material: 1.2344  
 Hardness: 65 ± 2 HRC. Head 45 ± 5 HRC.

**Order example**

UDSAN+d1+L ex. UDSAN4160 (4x160 mm)

# EJECTOR PINS

## EJECTOR PINS, DIN 1530, TYPE D - HARDENED

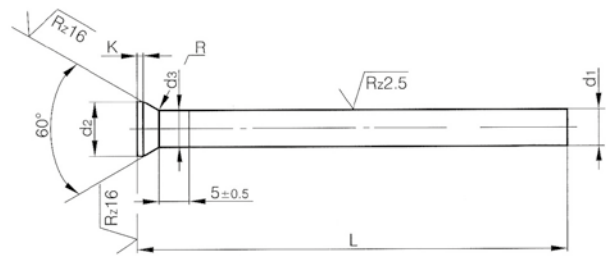

d1 g6	d2-0,2	k -0,05	R 0/+0,2	d3	L 0/+2				
					100	125	160	200	250
1	1,8	0,3	0,3	0,03	•	•	•	•	•
1,2	2	0,3	0,3	0,03	•	•	•	•	•
1,5	2,2	0,3	0,3	0,03	•	•	•	•	•
2	3	0,3	0,3	0,03	•	•	•	•	•
2,2	3,2	0,3	0,3	0,03	•	•	•	•	•
2,5	3,5	0,3	0,3	0,03	•	•	•	•	•
3	4,5	0,3	0,3	0,03	•	•	•	•	•
3,5	5	0,3	0,3	0,03	•	•	•	•	•
4	5,5	0,3	0,3	0,03	•	•	•	•	•
4,5	6	0,3	0,3	0,03	•	•	•	•	•
5	6,5	0,3	0,3	0,03	•	•	•	•	•
5,5	7	0,3	0,5	0,03	•	•	•	•	•
6	8	0,5	0,5	0,03	•	•	•	•	•
6,5	9	0,5	0,5	0,03	•	•	•	•	•
7	9	0,5	0,5	0,03	•	•	•	•	•
7,5	10	0,5	0,5	0,03	•	•	•	•	•
8	10	0,5	0,5	0,03	•	•	•	•	•
10	12	0,5	0,5	0,03	•	•	•	•	•
12	14	0,5	0,5	0,03	•	•	•	•	•
14	16	0,8	0,8	0,04	•	•	•	•	•
16	18	0,8	0,8	0,04	•	•	•	•	•

**Description**

Surface: Hardened and Polished  
 Material: 1.2516  
 Hardness: 60 ± 2 HRC. Head 45 ± 5 HRC.

**Order example**

UDSD+d1+L ex. UDSD4160 (4x160 mm)

**EJECTOR PINS, DIN 1530, TYPE CH - HARDENED**

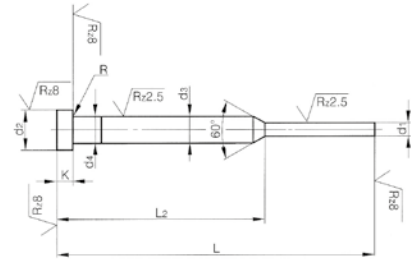

d1 g6	d2 0-0,2	d3 g6	k 0-0,05	R -0,05	L1	100	125	160	200	250
					L2	50	50	75	75	75
0,8	4	2	2	0,2		•	•	•	•	•
0,9	4	2	2	0,2		•	•	•	•	•
1,0	4	2	2	0,2		•	•	•	•	•
1,1	4	2	2	0,2		•	•	•	•	•
1,2	4	2	2	0,2		•	•	•	•	•
1,3	4	2	2	0,2		•	•	•	•	•
1,4	4	2	2	0,2		•	•	•	•	•
1,5	6	3	3	0,3		•	•	•	•	•
1,6	6	3	3	0,3		•	•	•	•	•
1,7	6	3	3	0,3		•	•	•	•	•
1,8	6	3	3	0,3		•	•	•	•	•
1,9	6	3	3	0,3		•	•	•	•	•
2,0	6	3	3	0,3		•	•	•	•	•
2,1	6	3	3	0,3		•	•	•	•	•
2,2	6	3	3	0,3		•	•	•	•	•
2,3	6	3	3	0,3		•	•	•	•	•
2,4	6	3	3	0,3		•	•	•	•	•
2,5	6	3	3	0,3		•	•	•	•	•

**Description**

Surface: Hardened and Polished  
 Material: 1.2516  
 Hardness: 60 ± 2 HRC. Head 45 ± 5 HRC.

**Order example**

UDSCH+d1+L ex. UDSCH2160 (2x160 mm)

# SLEEVE EJECTORS

## SLEEVE EJECTORS - HARDENED

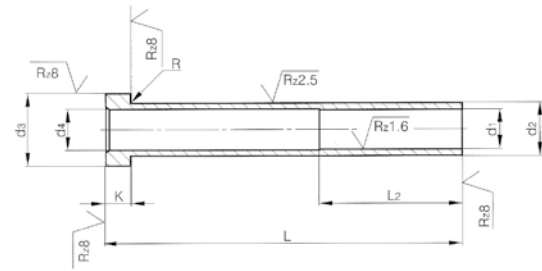

d2 g6	d1 H5	d4	d3 0 -0,2	k 0 -0,05	R +0,2 0	l2 +2 0	L 0/+2							
							75	100	125	150	175	200	225	250
4	2	2,4					•	•	•	•	•	•	•	•
	2,2	2,6	8				•	•	•	•	•	•	•	•
	2,5	2,9				35	•	•	•	•	•	•	•	•
5	2,7	3		3	0,3		•	•	•	•	•	•	•	•
	3	3,4	10				•	•	•	•	•	•	•	•
	3,2	3,6					•	•	•	•	•	•	•	•
6	3,5	3,9					•	•	•	•	•	•	•	•
	3,7	4					•	•	•	•	•	•	•	•
	4	4,4	12				•	•	•	•	•	•	•	•
8	4,2	4,6					•	•	•	•	•	•	•	•
	5	5,4		5	0,5		•	•	•	•	•	•	•	•
	5,2	5,6	14			45	•	•	•	•	•	•	•	•
10	6	6,4					•	•	•	•	•	•	•	•
	6,2	6,6					•	•	•	•	•	•	•	•
	8	8,4	16				•	•	•	•	•	•	•	•
12	8,2	8,6					•	•	•	•	•	•	•	•
	10	10,4	20	7	0,7		•	•	•	•	•	•	•	•
	12	12,4					•	•	•	•	•	•	•	•

**Description**

Surface: Hardened and Polished  
 Material: 1.2516  
 Hardness: 60 ± 2 HRC. Head 45 ± 5 HRC.

**Order example**

RUD(+d2+d1+L)H ex. RUD64125H (6x4x125mm)

**FLAT EJECTORS - HARDENED**

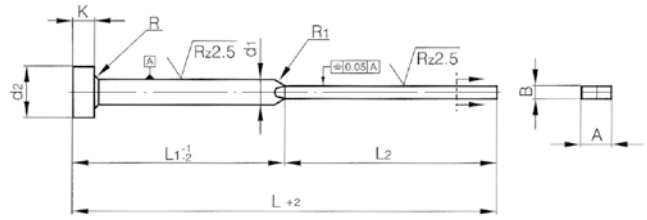

d1 g6	A +0 -0,015	B +0 -0,015	d2 +0 -0,2	K -0,05	L	100	125	160	200	250	315
					L1	50	65	80	100	125	160
					L2	50	60	80	100	125	155
4	3,5	1	8	3		•	•				
4,2	3,8	1	8	3		•	•	•			
4,2	3,8	1,2	8	3		•	•	•	•		
6	5,5	1,2	12	5		•	•	•	•		
6	5,5	1,5	12	5		•	•	•	•		
6	5,5	2	12	5		•	•	•	•		
8	7,5	1,2	14	5		•	•	•	•	•	•
8	7,5	1,5	14	5		•	•	•	•	•	•
8	7,5	2	14	5		•	•	•	•	•	•
10	9,5	1,5	16	5		•	•	•	•	•	•
10	9,5	2	16	5		•	•	•	•	•	•

**Description**

Surface: Hardened and Polished/Grinded  
 Material: 1.2516  
 Hardness: Schaft 60 ± 2 HRC. Head 45 ± 5 HRC.

**Order example**

FLU(+B+A+L)H ex. FLU25,5125H (2x5,5x125mm)

# CORE PINS

## CORE PINS ISO 6751 NON HARDENED (SOFT)

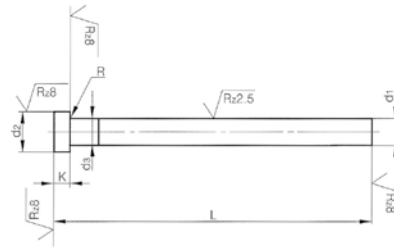

d1 g6	d2-0,2	k-0,05	R	d3	100	125	160	200	250	315
2	4	2	0,2	0,03	•	•	•	•		
2,2			0,3		•	•	•			
2,5	5	3			•	•	•			
3	6				•	•	•	•		
3,2					•	•	•	•		
3,5	7				•	•	•	•		
4	8				•	•	•	•		
4,2					•	•	•	•		
4,5					•	•	•	•		
5	10				•	•	•	•	•	
5,2					•	•	•	•		
5,5					•	•	•	•		
6	12	5	0,5		•	•	•	•	•	
6,2					•	•	•	•	•	
6,5					•	•	•	•	•	
7					•	•	•	•	•	
8	14				•	•	•	•	•	•
10				0,04	•	•	•	•	•	•
12	20	7			•	•	•	•	•	
16					•	•	•	•	•	•

**Description**

Surface: Nitrided and Polished  
 Material: 1.2344  
 Hardness: 40 ± 2 HRC. Head 45 ± 5 HRC

**Order example**

UDSAC+d1+L ex. UDSAC4160 (4X160 mm)



**DOWEL PINS, DIN 6325**

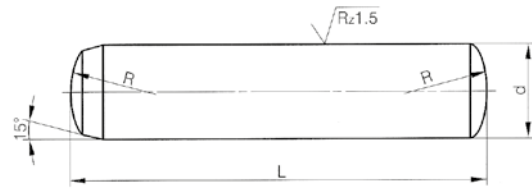

L \ d	2	3	4	5	6	8	10	12	14	16	20
6	•	•									
8	•	•	•	•							
10	•	•	•	•	•						
12	•	•	•	•	•	•					
14	•	•	•	•	•	•					
16	•	•	•	•	•	•	•				
18	•	•	•	•	•	•	•	•			
20	•	•	•	•	•	•	•	•	•		
24	•	•	•	•	•	•	•	•	•	•	
28	•	•	•	•	•	•	•	•	•	•	
32	•	•	•	•	•	•	•	•	•	•	•
36		•	•	•	•	•	•	•	•	•	•
40			•	•	•	•	•	•	•	•	•
45			•	•	•	•	•	•	•	•	•
50			•	•	•	•	•	•	•	•	•
55			•	•	•	•	•	•	•	•	•
60			•	•	•	•	•	•	•	•	•
70				•	•	•	•	•	•	•	•
80				•	•	•	•	•	•	•	•
90					•	•	•	•	•	•	•
100						•	•	•	•	•	•
120							•	•	•	•	•
130										•	•
140										•	•
150										•	•

**Description**

Surface: Hardened and Polished  
 Material: 1.3505  
 Tolerance: m6  
 Hardness: 60 ± 2 HRC.

**Order example**

CYL+d+L ex. CYL532 (5x32mm)

# DOWEL PINS

## DOWEL PINS - THREADED - DIN 7979

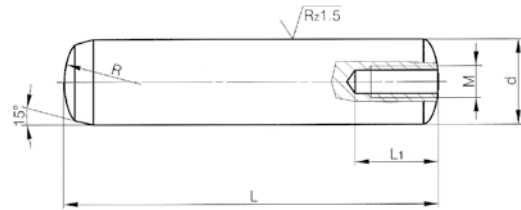

L1	10	12	16	16	20	20	25	
L	d	Ø 6 M4	Ø 8 M5	Ø 10 M6	Ø 12 M6	Ø 14 M8	Ø 16 M8	Ø 20 M10
16		•	•					
18		•	•					
20		•	•	•	•			
24		•	•	•	•			
28		•	•	•	•	•		
32		•	•	•	•	•	•	
36		•	•	•	•	•	•	
40		•	•	•	•	•	•	•
45		•	•	•	•	•	•	•
50		•	•	•	•	•	•	•
55		•	•	•	•	•	•	•
60		•	•	•	•	•	•	•
70		•	•	•	•	•	•	•
80		•	•	•	•	•	•	•
90		•	•	•	•	•	•	•
100		•	•	•	•	•	•	•
110		•	•	•	•	•	•	•
120		•	•	•	•	•	•	•

**Description**

Surface: Hardened and Polished  
 Material: 1.3505  
 Tolerance: m6  
 Hardness: 60 ± 2 HRC.

**Order example**

CYLG+d+L ex. CYLG832 (8x32mm)

**ANGLE GUIDE PIN**

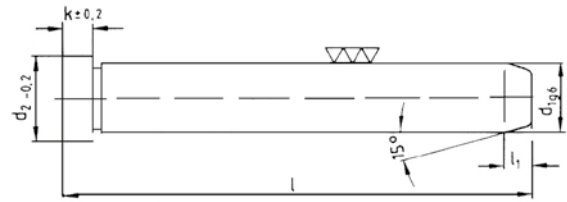

Part No.	d1 x l	d2	l1	k
EOC1040	10 x 40	12	4	3
EOC1060	10 x 60	12	4	3
EOC1080	10 x 80	12	4	3
EOC10100	10 x 100	12	4	3
EOC10120	10 x 120	12	4	3
EOC1260	12 x 60	16	7	6
EOC1280	12 x 80	16	7	6
EOC12100	12 x 100	16	7	6
EOC12120	12 x 120	16	7	6
EOC12140	12 x 140	16	7	6
EOC1460	14 x 60	18	7	8
EOC1480	14 x 80	18	7	8
EOC14100	14 x 100	18	7	8
EOC14120	14 x 120	18	7	8
EOC14140	14 x 140	18	7	8
EOC14160	14 x 160	18	7	8
EOC1680	16 x 80	20	7	8
EOC16100	16 x 100	20	7	8
EOC16120	16 x 120	20	7	8
EOC16140	16 x 140	20	7	8
EOC16160	16 x 160	20	7	8
EOC16180	16 x 180	20	7	8
EOC1860	18 x 60	22	7	8
EOC1880	18 x 80	22	7	8
EOC18100	18 x 100	22	7	8
EOC18120	18 x 120	22	7	8
EOC18140	18 x 140	22	7	8
EOC18160	18 x 160	22	7	8
EOC18200	18 x 200	22	7	8
EOC18240	18 x 240	22	7	8
EOC20100	20 x 100	24	7	8
EOC20120	20 x 120	24	7	8
EOC20160	20 x 160	24	7	8
EOC20200	20 x 200	24	7	8
EOC20240	20 x 240	24	7	8
EOC24100	24 x 100	28	7	15
EOC24120	24 x 120	28	7	15
EOC24140	24 x 140	28	7	15
EOC24160	24 x 160	28	7	15
EOC24200	24 x 200	28	7	15
EOC24240	24 x 240	28	7	15

**Description**

Surface: Hardened and Polished  
 Material: 1.7262  
 Tolerance: g6  
 Hardness: 60 ± 2 HRC

## SLIDE HOLDING DEVICES

### SLIDE HOLDING DEVICES

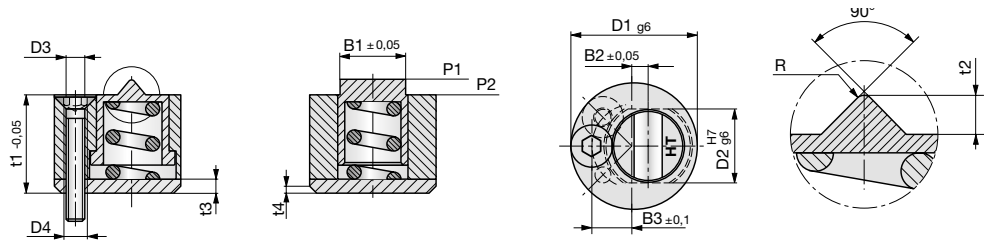

Part No.	D1	B1	B2	B3	t1	t2	t3	t4	D2	D3	D4	R	P1	P2
SHD13	13	6,6	1,4	4,3	10	1,0	1,6	0,35	7	2,2	M3	0,35	28 N	34 N
SHD18	18	9,6	2,0	6,0	14	1,8	2,0	0,50	10	3,2	M4	0,5	38 N	42 N
SHD27	27	14,4	3,0	9,0	21	2,8	3,0	0,50	15	4,3	M5	0,75	38 N	92 N

**Description**

Material: 1.2767/~-52HRC  
 Max. 100 °C

### SLIDE HOLDING DEVICES

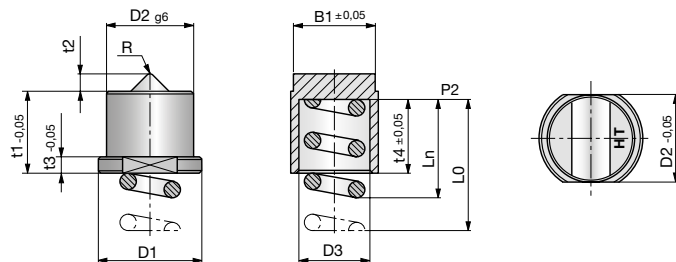
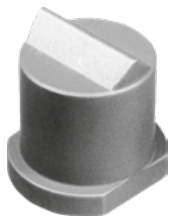

Part No.	D2	B1	t1	t2	t3	t4	D1	D3	R	L0	Ln	P2
SID7	7	6,6	7	1,0	1,4	6,3	8,4	5,3	0,35	12	7,5	34 N
SID10	10	9,6	10	1,8	2,0	9,0	12,0	8,3	0,50	16	10,0	42 N
SID15	15	14,4	15	2,8	3,0	13,5	18,0	12,4	0,75	18	16,0	92 N

**Description**

Material: 1.2767/~-52HRC  
 Max. 100 °C

**SLIDE HOLDING DEVICES - TYPE 0**

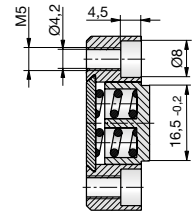
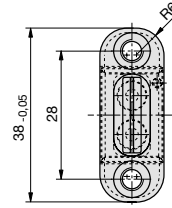
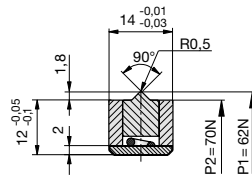

**SLIDE HOLDING DEVICES - TYPE 1**

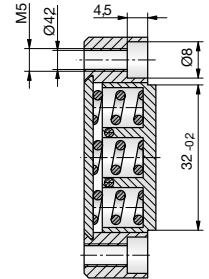
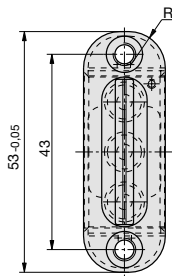
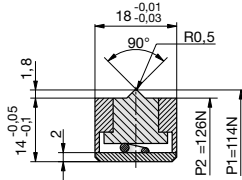

**SLIDE HOLDING DEVICES - TYPE 2**

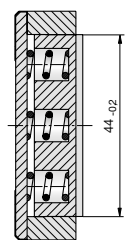
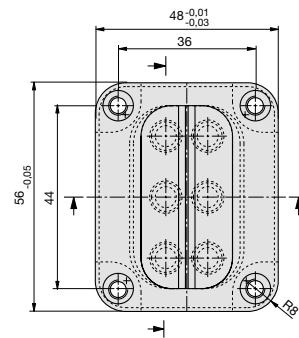
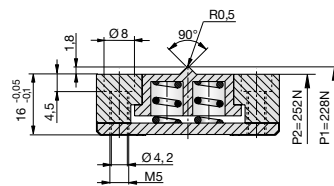

Part No.	Type
SHD0	0
SHD1	1
SHD2	2

**Description**  
 Material: 1.2343 -52 HRC  
 Max. 100 °C

# SOCKET HEAD CAP SCREWS

## SOCKET HEAD CAP SCREWS

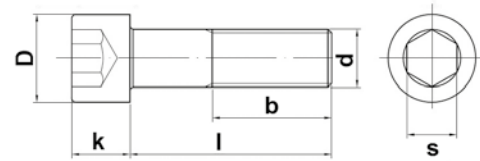

d	M1,6	M2	M2,5	M3	M4	M5	M6	M8	M10	M12	M14	M16	M18	M20	M24
Thread-pitch	0,35	0,40	0,45	0,50	0,70	0,80	1,00	1,25	1,50	1,75	2,00	2,00	2,50	2,50	3,00
D	3	3,8	4,5	5,5	7	8,5	10	13	16	18	21	24	27	30	36
k	1,6	2	2,5	3	4	5	6	8	10	12	14	16	18	20	24
b	15	16	17	18	20	22	24	28	32	36	40	44	48	52	60
s	1,5	1,5	2	2,5	3	4	5	6	8	10	12	14	14	17	19

Length	Thread Size Metric															
	1,6	2	2,5	3	4	5	6	8	10	12	14	16	18	20	24	
3		•														
4	•	•														
5		•	•	•	•											
6	•	•	•	•	•	•										
8		•	•	•	•	•	•									
10		•	•	•	•	•	•	•	•							
12		•	•	•	•	•	•	•	•	•						
14			•	•	•	•	•	•	•	•	•					
15			•	•	•	•	•	•	•	•	•	•				
16			•	•	•	•	•	•	•	•	•	•	•			
18				•	•	•	•	•	•	•	•	•	•	•		
20				•	•	•	•	•	•	•	•	•	•	•	•	
22					•	•	•	•	•	•	•	•	•	•	•	•
25				•	•	•	•	•	•	•	•	•	•	•	•	•
30				•	•	•	•	•	•	•	•	•	•	•	•	•
35					•	•	•	•	•	•	•	•	•	•	•	•
40					•	•	•	•	•	•	•	•	•	•	•	•
45					•	•	•	•	•	•	•	•	•	•	•	•
50					•	•	•	•	•	•	•	•	•	•	•	•
55						•	•	•	•	•	•	•	•	•	•	•
60						•	•	•	•	•	•	•	•	•	•	•
65						•	•	•	•	•	•	•	•	•	•	•
70						•	•	•	•	•	•	•	•	•	•	•
75							•	•	•	•	•	•	•	•	•	•
80							•	•	•	•	•	•	•	•	•	•
90							•	•	•	•	•	•	•	•	•	•
100							•	•	•	•	•	•	•	•	•	•
110							•	•	•	•	•	•	•	•	•	•
120							•	•	•	•	•	•	•	•	•	•
130								•	•	•	•	•	•	•	•	•
140								•	•	•	•	•	•	•	•	•
150								•	•	•	•	•	•	•	•	•
160								•	•	•	•	•	•	•	•	•
180								•	•	•	•	•	•	•	•	•
200								•	•	•	•	•	•	•	•	•

**Description**

Material: High tensile strength (12.9)  
DIN 912/ISO 4762

**Order example**

HCS-(Thread Size + (-)+Length) ex. HCS-16-35 (M16x35mm)

**SHOULDER SCREWS, ISO 7379**

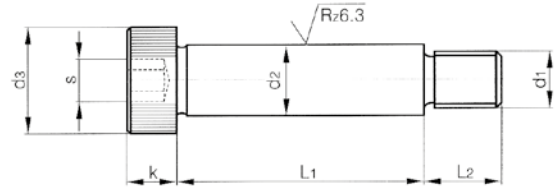

d2h8	6	8	10	12	16	20	24
d1	5 X 0,8	6 X 1	8 X 1,25	10 X 1,5	12 X 1,75	16 X 2	20 X 2,5
d3	10	13	16	18	24	30	36
K	4,5	5,5	7	8	10	14	16
L2	9,5	11	13	16	18	22	27
S	3	4	5	6	8	10	12
Kg/mm	0,68	1,15	3	6	11	28	55

L1	L1 h11						
10	•						
12	•	•					
16	•	•	•				
20	•	•	•	•			
25	•	•	•	•	•		
30	•	•	•	•	•	•	
35	•	•	•	•	•	•	
40	•	•	•	•	•	•	•
45	•	•	•	•	•	•	•
50	•	•	•	•	•	•	•
55		•	•	•	•	•	•
60		•	•	•	•	•	•
65		•	•	•	•	•	•
70		•	•	•	•	•	•
80			•	•	•	•	•
90				•	•	•	•
100				•	•	•	•
120				•	•	•	•

**Description**

Material: High tensile strength (12.9)  
ISO 7379

**Order example**

UNBH+d2+L1 ex. UNBH610 (6 x 10 mm)

# SPRING PLUNGERS

## SPRING PLUNGER, BALL TYPE

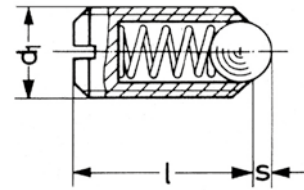

Part No.	d1	l	s	Ball Ø
WZ8087M3	M3	7	0,5	1,5
WZ8087M4	M4	9	0,8	2,5
WZ8087M5	M5	12	0,9	3
WZ8087M6	M6	14	1,0	3,5
WZ8087M8	M8	16	1,5	5
WZ8087M10	M10	19	2,0	6
WZ8087M12	M12	22	2,5	8
WZ8087M16	M16	24	3,5	10

**Description**  
Material 1.0718

## SPRING PLUNGER, PIN TYPE

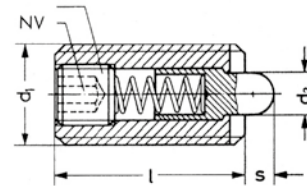

Part No.	d1	l	s	d2	NV
WZ8090M3	M3	12	1	1	0,7
WZ8090M4	M4	15	1,5	1,5	1,3
WZ8090M5	M5	18	2,3	2,4	1,5
WZ8090M6	M6	20	2,5	2,7	2
WZ8090M8	M8	22	3	3,5	2,5
WZ8090M10	M10	22	3	4	3
WZ8090M12	M12	28	4	6	4
WZ8090M16	M16	32	5	7,5	5

**Description**  
Material 1.0718

## SPRING PLUNGER, STRAIGHT

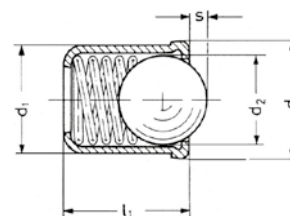

Part No.	d1	l1	s	d2	d3
WZ80934	4	5	0,7	3	4,6
WZ80935	5	6	1	4	5,6
WZ80936	6	7	1,5	5	6,5
WZ80938	8	9	1,8	6,5	8,5

**Description**  
Material: 1.4303



**DIE SPRINGS ISO 10243 - STEEL**

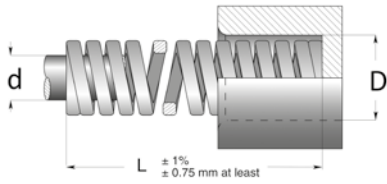

D x L	d	Type V Green	Type B Blue	Type R Red	Type G Yellow
10 x 38	5	•	•	•	•
10 x 44	5	•	•	•	•
10 x 51	5	•	•	•	•
10 x 64	5	•	•	•	•
10 x 76	5	•	•	•	•
10 x 305	5	•	•	•	•
13 x 25	6,3	•	•	•	•
13 x 32	6,3	•	•	•	•
13 x 38	6,3	•	•	•	•
13 x 44	6,3	•	•	•	•
13 x 51	6,3	•	•	•	•
13 x 64	6,3	•	•	•	•
13 x 76	6,3	•	•	•	•
13 x 89	6,3	•	•	•	•
13 x 102	6,3	•	•	•	•
13 x 305	6,3	•	•	•	•
16 x 25	8	•	•	•	•
16 x 32	8	•	•	•	•
16 x 38	8	•	•	•	•
16 x 44	8	•	•	•	•
16 x 51	8	•	•	•	•
16 x 64	8	•	•	•	•
16 x 76	8	•	•	•	•
16 x 89	8	•	•	•	•
16 x 102	8	•	•	•	•
16 x 115	8	•	•	•	•
16 x 305	8	•	•	•	•
20 x 25	10	•	•	•	•
20 x 32	10	•	•	•	•
20 x 38	10	•	•	•	•
20 x 44	10	•	•	•	•
20 x 51	10	•	•	•	•
20 x 64	10	•	•	•	•
20 x 76	10	•	•	•	•
20 x 89	10	•	•	•	•
20 x 102	10	•	•	•	•
20 x 115	10	•	•	•	•
20 x 127	10	•	•	•	•
20 x 139	10	•	•	•	•
20 x 152	10	•	•	•	•
20 x 305	10	•	•	•	•

**Order example**

Type + Dimension + Length: V10076 (Green  $\varnothing$  10 x 76 mm)  
V10305 (Green  $\varnothing$  10 x 305 mm)

# ISO SPRINGS

## DIE SPRINGS ISO 10243 - STEEL

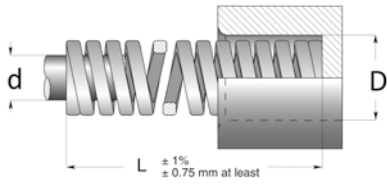

D x L	d	Type V Green	Type B Blue	Type R Red	Type G Yellow
25 x 25	12,5	•	•	•	•
25 x 32	12,5	•	•	•	•
25 x 38	12,5	•	•	•	•
25 x 44	12,5	•	•	•	•
25 x 51	12,5	•	•	•	•
25 x 64	12,5	•	•	•	•
25 x 76	12,5	•	•	•	•
25 x 89	12,5	•	•	•	•
25 x 102	12,5	•	•	•	•
25 x 115	12,5	•	•	•	•
25 x 127	12,5	•	•	•	•
25 x 139	12,5	•	•	•	•
25 x 152	12,5	•	•	•	•
25 x 178	12,5	•	•	•	•
25 x 203	12,5	•	•	•	•
25 x 305	12,5	•	•	•	•
32 x 38	16	•	•	•	•
32 x 44	16	•	•	•	•
32 x 51	16	•	•	•	•
32 x 64	16	•	•	•	•
32 x 76	16	•	•	•	•
32 x 89	16	•	•	•	•
32 x 102	16	•	•	•	•
32 x 115	16	•	•	•	•
32 x 127	16	•	•	•	•
32 x 139	16	•	•	•	•
32 x 152	16	•	•	•	•
32 x 178	16	•	•	•	•
32 x 203	16	•	•	•	•
32 x 254	16	•	•	•	•
32 x 305	16	•	•	•	•

**Order example**

Type+ Dimension+Length: V10076 (Green ø 10 x 76 mm)  
 V10305 (Green ø 10 x 305 mm)

**DIE SPRINGS ISO 10243 - STEEL**

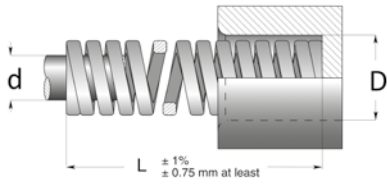

D x L	d	Type V Green	Type B Blue	Type R Red	Type G Yellow
40 x 51	20	•	•	•	•
40 x 64	20	•	•	•	•
40 x 76	20	•	•	•	•
40 x 89	20	•	•	•	•
40 x 102	20	•	•	•	•
40 x 115	20	•	•	•	•
40 x 127	20	•	•	•	•
40 x 139	20	•	•	•	•
40 x 152	20	•	•	•	•
40 x 178	20	•	•	•	•
40 x 203	20	•	•	•	•
40 x 254	20	•	•	•	•
40 x 305	20	•	•	•	•
50 x 64	25	•	•	•	•
50 x 76	25	•	•	•	•
50 x 89	25	•	•	•	•
50 x 102	25	•	•	•	•
50 x 115	25	•	•	•	•
50 x 127	25	•	•	•	•
50 x 139	25	•	•	•	•
50 x 152	25	•	•	•	•
50 x 178	25	•	•	•	•
50 x 203	25	•	•	•	•
50 x 229	25	-	•	-	-
50 x 254	25	•	•	•	•
50 x 305	25	•	•	•	•
63 x 76	38	•	•	•	•
63 x 89	38	•	•	•	•
63 x 102	38	•	•	•	•
63 x 115	38	•	•	•	•
63 x 127	38	•	•	•	•
63 x 152	38	•	•	•	•
63 x 178	38	•	•	•	•
63 x 203	38	•	•	•	•
63 x 229	38	-	•	-	-
63 x 254	38	•	•	•	•
63 x 305	38	•	•	•	•

**Order example**

Type + Dimension + Length: V10076 (Green  $\varnothing$  10 x 76 mm)  
 V10305 (Green  $\varnothing$  10 x 305 mm)

# MOULD CYCLE COUNTER

## MOULD CYCLE COUNTER

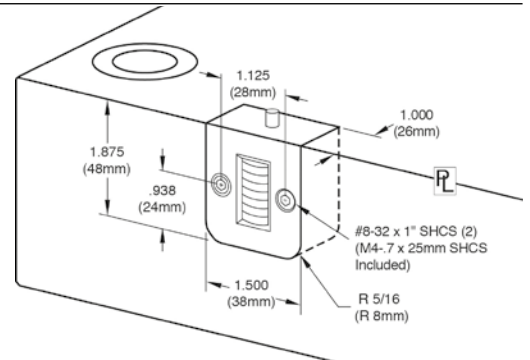

Part No.	# Digit	Colour	Temp. range
CC200	7	Black	120° C

### Description

Mouldpro Cycle Counter positively monitors mould activity, validates process monitoring data, and assists mould maintenance procedures.

- Maximum operating temperature is 120° C
- Counter: Non-resettable mechanical, 7-digit
- Glass-filled Nylon housing
- Reliable and tested quality
- Specified worldwide by leading OEM's
- Supplied with serial Number
- Socket head cap screws are included

**ROUND COUNTER - RIGHT HAND**



**ROUND COUNTER - LEFT HAND**

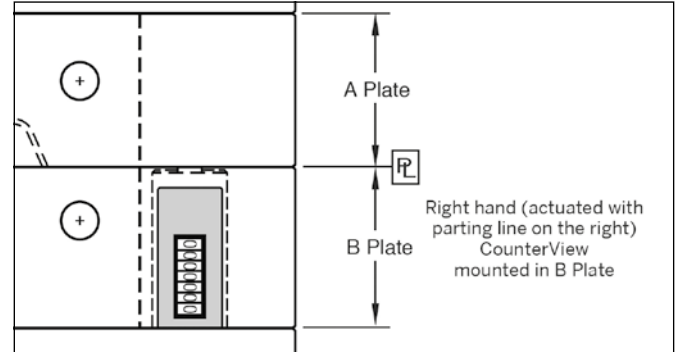
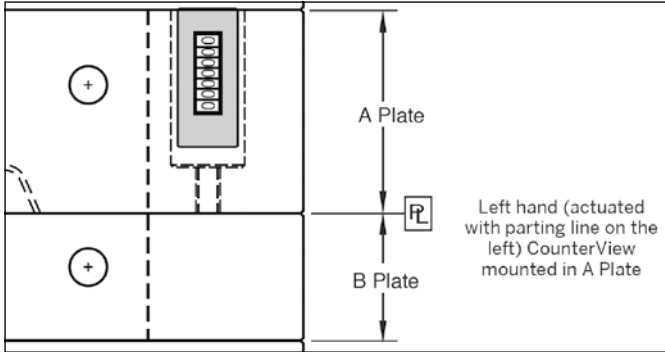

Part No.	Direction	# Digit	Colour	Temp. Range
CR100	Right hand	7	Black	120°C
CL100	Left hand	7	Black	120°C

**Description**

The Round counters can be installed in the A or B plates with a minimum thickness of 1.875" (47mm). Larger plates utilize a threaded rod (included with each) that is pre-machined to the appropriate length for standard plate thicknesses to provide consistent actuation.

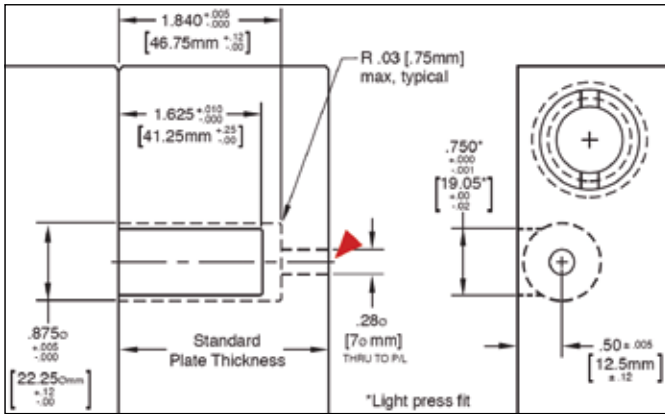

▶ CAD insertion point

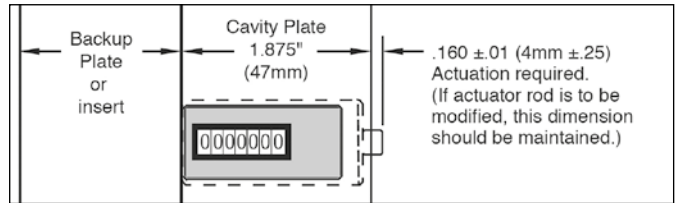

**EXTENSION RODS**

Part No.	L
CER-56	56
CER-66	66
CER-76	76
CER-96	96
CER-116	116
CER-196	196

**Description**

L=Length to make plate thickness

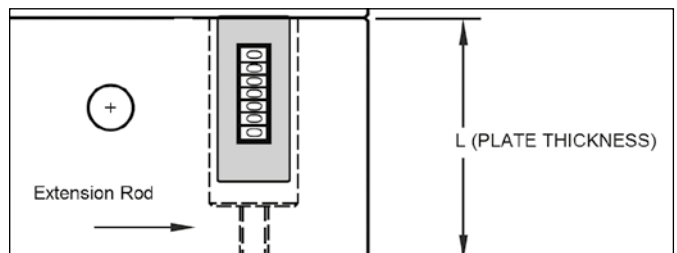

## Copyright, Disclaimer

Mouldpro ApS makes every effort to maintain the accuracy and quality of the information provided in this Catalogue. However, Mouldpro cannot guarantee and assumes no legal liability or responsibility for the accuracy or completeness of the information provided. The information contained in this catalogue is for general guidance only. You should neither act, nor refrain from action, on the basis of any such information. You should take appropriate professional advice on your particular circumstances because the application of our equipment may vary depending on particular circumstances.

The copyright of all content in this catalogue is owned by Mouldpro and/or the various manufacturers of our equipment. No part of the Mouldpro catalogue may be changed, reproduced, stored in or transmitted on any website or medium without the prior written permission of Mouldpro.

In case of any questions or remarks, feel free to contact us.





Distributor

**MOULDPRO A/S**

Baltorpbakken 10  
DK-2750 Ballerup Denmark  
[www.mouldpro.com](http://www.mouldpro.com)